

SIPCO i.Mak[®]

Gearboxes and Drives

Product Catalog

Three-Phase Asynchronous Motors

M01

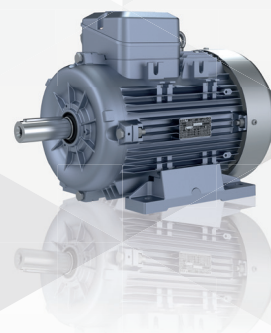

2020

EN

Electric Motors

Three-Phase Asynchronous Electric Motors



General Technical Information	
Mechanical Properties	07
Single-row Ball Bearings	10
Bearing Installation Schemes	11
Permissible Radial Forces	12
Permissible Axial External Forces	13
Sound (Noise) Levels	15
Construction Types and Mounting Layouts	16
Electrical Design and Technical Data	
Voltage and Fequency	18
Rated Power	19
Terminal Connection and Starting Methods	23
Dimensions	
Aluminium Series	47
Cast Iron Series	49
Flange Sizes	
Sizes	53



DESCRIPTION OF TYPE CODES

X1	X2	X3	X4	X5	X6
AB	P	200	L	4	A
CODE	DESCRIPTION				
X1	Motor body types				
	AA	Aluminium frame			
	AB	Iron Cast frame			
X2	Efficiency class				
		IE1 Standard Efficiency			
	H	IE2 High Efficiency			
	P	IE3 Premium Efficiency			
X3	Frame Size				
	63-355	Shaft axis Height above ground			
X4	Frame length				
	S	Short			
	M	Medium			
	L	Long			
X5	Number of poles [Rotation Speed]				
	2	2 pole, 3000 rpm			
	4	4 pole, 1500 rpm			
	6	6 pole, 1000 rpm			
	8	8 pole, 750 rpm			
	2/4	2/4 pole, 3000/1500 rpm			
	4/8	4/8 pole, 1500/750 rpm			
	6/8	6/8 pole, 1000/750 rpm			
X6	Stack length				
	A	Short			
	B	Medium			
	C	Long			
ABP200L4A					
	3~	3-phase Electric Motor			
S1					
	TSE	Turkish Standards Conformity Mark			
IE3					
	IEC/EN 60034	Related Standards			
Bearing					
	Serial No	Motor Serial Number			
IP55					
	İzo.KL	Insulation Class			
Kg					
	BG	Rated Power [hp]			
kW					
	cosφ	Rated Power Factor			
50 Hz – 60 Hz					
	rpm	Rotation Speed Of The Motor At Nominal Pow. And Freq.			
Δ / λ					
	V	Rated Operating Voltage			
I					
		Rated Operating Current			

		3 ~MOT				IEC 60034-1			
Tip : ABP200L4A		TT :6312 ZCC3 SKF		Izo.F		FT :6212 ZCC3 SKF		S1	
Seri No:		-20 °C < T ort < 40 °C		250 kg		Tarih :		MADE IN TURKEY	
V	Hz	A	kW	COS	d/dak	IE-CL	Verim		
400 Δ	50	52,8	30	0,89	1470	IE3	%50	%75	%100
690 λ	50	30,5	30	0,89	1470				
460 Δ	60	52,8	34,5	0,90	1765				
796 λ	60	30,5	34,5	0,90	1765				



This catalogue has been prepared with the aim of giving information for mechanical and electrical values of 3-phase, cage rotor, completely closed, 63-355 build size asynchronous motors manufactured for public use needed by the industry, in accordance with the "TS" standards of the Turkish Standards Institute and "IEC" standards of the International Electrotechnical Commission. I-MAK motors are manufactured in accordance with national and international standards.

STANDARDS ADHERED TO IN DESIGN

TS	IEC	DIN/EN	DESCRIPTION
TS EN 60034-1	60 034-1	EN 60 034-1	Performance and classification
TS EN 60034-2-2	60 034-2	EN 60 034-2	Losses and efficiency value and calculation methods in rotating electrical machines
TS EN 50 347	60 072-1	EN 50347	Dimensions and nominal power of foot-mounting and flange 3-phase electrical machinery
TS 3209 EN 60034-5/A1	60034-5-AMD1	DIN EN 60 034-5	Protection classes [against foreign objects and dust]
TS 3210 EN 60034-6	60 034-6	EN 60 034-6	Cooling methods
TS 3211 EN 60034-7	60 034-7	EN 60 034-7	Construction types, mounting and terminal box position
TS EN 60034-8/A1	60 034-8	EN 60 034-8	Marking of terminals and direction of rotation
TS EN 60034-9/A1	60 034-9	EN 60 034-9	Noise limit values
TS EN 60 034-11	60 034-11	EN 60 034-11	Thermal protection rules
TS 6848 EN 60 034-12/A1	60 034-12	EN 60 034-12	Starting characteristics
TS EN 60 034-14/A1	60 034-14	EN 60 034-14	Mechanical vibration levels
TS EN 60038	60 038	EN 60 038	Standard voltage
TS EN 60085	60 038	EN 60 085	Classification of insulating material
TS EN 50 347	60 072-1	DIN EN 50347	Cylindrical shaft ends
		DIN 42925	Terminal box cable entries

MECHANICAL FEATURES

HOUSING, END SHIELDS AND FLANGES

Materials of frames, covers and flanges used in IMAK Electric Motors are summarized in the following table.

Frame Size	Housings	Covers	B5	Flanges B14	B14 Special
63	Aluminium	Aluminium	Aluminium	Aluminium	Cast Iron
71					
80					
90					
100					
112					
132	Aluminium or Cast Iron	Aluminium or Cast Iron	Aluminium or Cast Iron	Aluminium or Cast Iron	-
160				Cast Iron	
180				-	
200				-	
225	Cast Iron	Cast Iron	Cast Iron	-	-
250					
280					
315					
355					

The motor is manufactured with the feet connected to the frame.

On All cast iron motors of size of between 132-355 are threaded to attach lifting eye in accordance with DIN 580.

MOTOR PROTECTION CLASSES

Motors are classified with the IP code according to their degree of protection. This classification is expressed by initials of "Ingress Protection" and two characteristic digits in accordance with TS 3209 EN 60034-5/Al.

It is a classification that determines the degree to which foreign objects and water penetrating into the motor can access to parts of motor which may cause danger for electric or moving parts of the motor. The first digit specifies the degree of protection against solid matters and the second number specifies the degree of protection against water.

Amount	First Digit Protection Against Solids	Second Digit Protection Against Liquids
	Unprotected	Unprotected
1	Protection against objects larger than 50 mm	Protection against water from vertical
2	Protection against objects larger than 12 mm	Protection against water spray up to an angle of 15 degrees from vertical
3	Protection against objects larger than 2.5 mm	Protection against water spray up to an angle of 60 degrees from vertical
4	Protection against objects larger than 1 mm	Protected against sprayed water from any direction.
5	Protection against dust Complete protection against random contact with voltage in the motor or moving parts inside the body. The amount dust entering the machine would not be sufficient to cause damage to the machine's operation although its influence cannot be prevented completely.	Protection against damaging low-pressure water spray from any direction
6	Fully protected against the ingress of dust	Protection against heavy sea and weather conditions or strong water spray from all directions
7		Protection against immersion for 30 minutes at depths between 15cm and 1m
8		Protection against long-term water immersion at depth of 1-3 m

I-MAK Electric Motors are produced in accordance with IP 55 protection rating as standard to operate in dusty and humid environments. Motors can operate in a closed area, without direct sunlight, under mild atmospheric conditions without any additional measures. It is necessary to take the necessary protective measures, to use a special paint, to select protection class IP56, to use a special lacquer at winding head against excessive humidity, etc. for motors to be used in extremely harsh climate conditions such as high humidity, outdoor conditions, corrosive chemicals or coastal areas. While ordering, it is necessary to select the appropriate motor, specifying the non-standard environmental conditions. Upgraded protection class motors are manufactured upon customer demand.



DRAINAGE HOLE FOR CONDENSED WATER AND HEATER TO PREVENT CONDENSATION

In motors to operate in extreme temperature differences or climatic conditions, the drain hole is drilled on the lowest point of the motor in order to drain the condensed water. Drain holes are sealed with plastic blind stopper. If blind stopper is opened, the protection class would be IP44.

If there is the possibility of a dangerous condensation in the winding, water condensation is prevented by placing 1 heater in the total power given in the table below due to special climatic conditions changing in wide temperature ranges or being in a humid environment for a long time. Heaters should be supplied from an independent source and deactivated before motor is started.

Size of Structure	Heater	
	Voltage [V]	Total power [W]
63-71-80-90-100	220	26
112-132	220	42
160-180	220	65
200	220	85
225	220	90
250-280	220	100
315-355	220	120

Another solution to avoid condensation is to use an auto-transformer. A value between 5-10% of the rated voltage and 20-30% of the rated current is applied between UI-VI.

COOLING

Standard IMAK motors are cooled from the outer surface [TS 3210 EN 60034-6- IC411], with propeller made of Polyamide. Propeller is mounted on motor shaft from the rear and motor rotation direction does not prevent the function of the fan. The propeller is protected by the housing manufactured from perforated sheet allowing sufficient air flow to the rear surface and in size to prevent fingers to enter the holes. Motor should be mounted, leaving enough space so that the motor's cooling fan is not blocked. Optionally, motor, cooled by free spread without propeller is produced in accordance with IC410.

TERMINAL BOX

It is located on top middle section for frame size 63, and for frames 71-80-90-100-112-132-160-180-200-225-250-280-315, it is located on top close to shaft side. According to customer demands for sizes 71-80-90-100-112-132-160-180-200-225-250-280-315 it can rotate on the four sides of the motor. For frame size 355 the terminal box located on the top right side with 45 angle looking from shaft side, according to demands it can be located on the top left side with 45 angle looking from shaft side.

Terminal box is produced according to IP65 protection class. In addition to 6 cable tips, there is a grounding screw which is connected directly to the frame itself. Terminal boxes are produced from the same material as the frames.

CABLE ACCESS

Cable entries to the terminal box are made using standard couplings in holes drilled in accordance with DIN 42 925. Optionally, IP68 waterproof fittings are used.

Size of Structure	Connection box type	Number of terminals	Connector nut	Maximum conductor cross-section	The largest cable outer diameter	Cable Glands
63	KK 63	6	M4	1,5	11	M20x1,5k
71	KK 71-90	6	M4	2,5	16	M20x1,5k
80	KK 71-90	6	M4	2,5	16	M20x1,5k
90	KK 71-90	6	M4	2,5	16	M20x1,5k
100	KK 100-112	6	M5	2,5	16	2xM20x1,5
112	KK 100-112	6	M5	2,5	16	2xM20x1,5
132	KK 132	6	M5	6	21	2xM25x1,5
160	KK 160-180	6	M6	16	29	2xM32x1,5
180	KK 160-180	6	M6	16	29	2xM32x1,5
200	KK 200-225	6	M8	50	36	2xM40x1,5 M12x1,5
225	KK 200-225	6	M8	50	36	2xM40x1,5 M12x1,5
250	KK 250	6	M10	120	42	2xM50x1,5 M12x1,5
280	KK 280	6	M10	120	42	2xM50x1,5 M12x1,5
315	KK 315	6	M12	240	48	2xM63x1,5 M12x1,5
355	KK 355	6	M16	400	59	3xM63x1,5 M12x1,5

ROW BALL BEARING

I-MAK Electric Motors have high-quality, smooth-running bearings with fixed balls in conformity with DIN 625-1 and cylindrical roller bearings in conformity with DIN 5412-1. As standard, single-row bearings are used in the drive (front) and fan (back) side, specified in the following table. Cylindrical roller bearings indicated in the table on page 9 are used when radial force greater than the values in the radial forces table on page 9 are needed. Please contact I-MAK for information and ordering if you need motors to operate in great force other than radial forces defined in the table.

ROW BALL BEARING

Motor Type	Number of	* DE Bearing	** NDE Bearing	Figure No
63 M	2-4	6002 ZXC3	6002 ZXC3	Fig. 1 and Fig. 2
71 M	2-4-6-8	6202 ZXC3	6202 ZXC3	
80 M	2-4-6-8	6004 ZXC3	6004 ZXC3	
90 S/L	2-4-6-8	6205 ZXC3	6004 ZXC3	
100 L	2-4-6-8	6206 ZXC3	6205 ZXC3	
112 M	2-4-6-8	6206 ZXC3	6205 ZXC3	
132 S/M	2-4-6-8	6208 ZXC3	6208 ZXC3	
160 M/L	2-4-6-8	6309 ZXC3	6209 ZXC3	
180 M/L	2-4-6-8	6310 ZXC3	6210 ZXC3	
200 L	2-4-6-8	6312 ZXC3	6212 ZXC3	
225 S/M	2-4-6	6313 ZXC3	6213 ZXC3	Fig.2
250 M	2-4-6	6315 ZXC3	6215 ZXC3	
280 S/M	2-4-6	6316 ZXC3	6315 ZXC3	Fig.3
315 S/M/L	2	6316 C3	6316 C3	
	4-6	6319 C3	6319 C3	
355 M/L	2	6318 C3	6318 C3	
	4-6	6322C3	6321 C3	

CYLINDRICAL ROLLER BEARING

Please consult us, as cylindrical roller design is needed when you need greater radial power with belt/pulley drive applications. Bearing selection table is for planning and selection purposes. Please consult us for precise knowledge of what types of bearings should be used with motors produced with greater power. Sound and vibration values of NU motors are given on demand. Motors are shipped horizontally, and can be shipped vertically upon request.

Cylindrical Roller Bearings Used in Enhanced Motors

Motor Type	Number of	* DE Bearing	** NDE Bearing	Figure No
180 M/L	2-4-6-8	NU 310 E	6210 ZXC3	Şek. 3
200 L	2-4-6-8	NU 312 E	6212 ZXC3	Şek. 3
225 S/M	2-4-6	NU 313 E	6213 ZXC3	Şek. 3
250 M	2-4-6	NU 315 E	6215 ZXC3	Şek. 3
280 S/M	2-4-6	NU 316 E	6315 ZXC3	Şek. 3
315 S/M	2	NU 316 E	6316 C3	Şek. 3
315 S/M	4-6	NU 319 E	6319 C3	Şek. 3
355 S/M	2	NU 318 E	6318 C3	Şek. 3
355 S/M	4-6	NU 322 E	6321 C3	Şek. 3

Fixed bearing is standard for the shafts of motors with 160 size and over on non-drive end shield. If motors in sizes 180-355, it is manufactured as in Figure 3 with reinforced design, cylindrical roller bearing and lubrication lid. Permissible radial forces and axial forces can be found on page 12 on page 13, respectively.

* DE: Drive End ** NDE: Non-Drive End

BEARING INSTALLATION SCHEMES

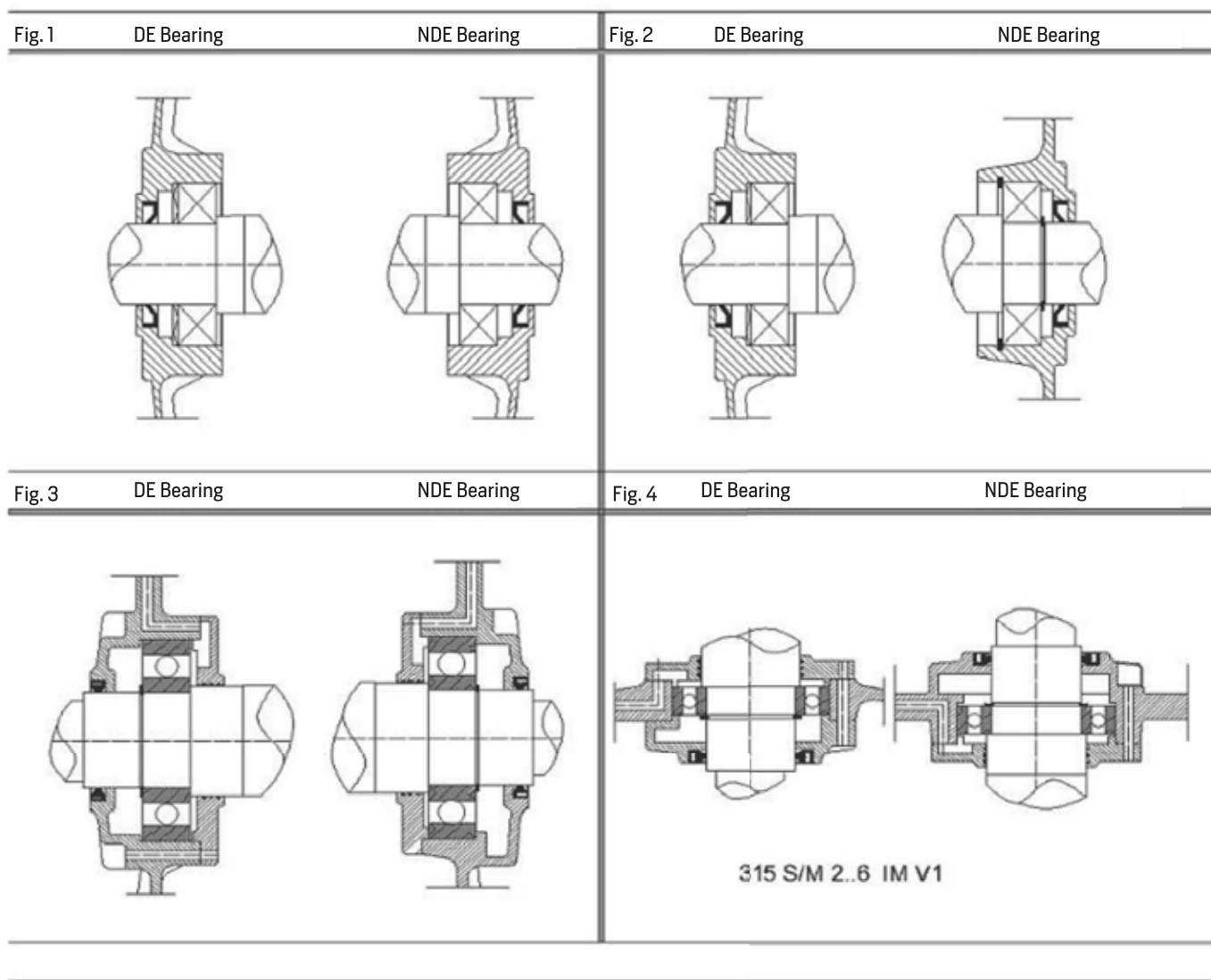

MAINTENANCE OF BEARINGS

A carrier layer of lubricant on the bearings raceway provides the following benefits.

It reduces friction and rolling force,

Reduce wear and rust,

It reduces bearing's operation sound to a minimum level,

It helps to reduce the heat generated by the bearing.

Mineral oil based, lithium-based grease is used in closed type bearings used in motors, with resisting temperature from -30C up to + 180C. Proper grease should be selected according to the conditions if the motor will operate at temperatures higher than 40Co, which is indicated in the catalogue. Open type bearings should be filled with grease up to 1/3 of internal space volume of bearing. Bearings should be lubricated as specified in the maintenance manual. Bearings operating in harsh conditions must be lubricated with a maximum interval of 3 years or less.

Bearing life varies according to horizontal and axial forces on the shaft. If there are no horizontal and axial force on the shaft, bearing life is approximately 40,000 hours. Permissible horizontal and axial forces are prepared in accordance with 20,000 hours of operation life and 50hz network frequency.

PERMISSIBLE MECHANICAL FORCES

The force unit is taken as Newton in the table of permissible radial and axial forces. If mechanical forces on the bearing is more than the values specified in tables, the structural size of the motor, operation type, operating speed, form, board layout, load application point, of the characteristics of the load [variable, direction, size], the type of machine to be driven, motor and machine connection type [pulleys, couplings etc.] should be specified at order stage and the design should be appropriate.

PERMISSIBLE RADIAL FORCES

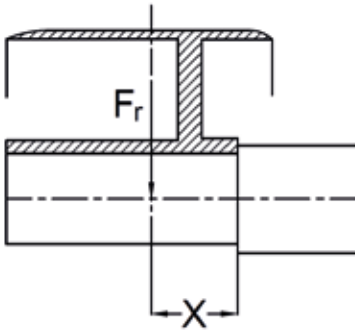

Fig. 6

To calculate the extra radial forces on the shaft, centre of the pulley is considered the axis of force, the force perpendicular to the shaft is called "Fr", the distance of the force of the shaft bill is called "x";

Radial force;
$$F_r = 2 \cdot 10^7 \cdot \frac{P \cdot k}{n \cdot D} \text{ (N)}$$

Fr = radial force,

X = distance between the shoulder of shaft and force application point [mm], the largest value of X is the length of shaft. The axis of the pulley must not exceed the maximum value of x.

P = motor power [kW] n = Speed at full load [rpm]

D = diameter of pulley [mm]

k = belt tension factor [about] will be k = 2, [if it is flat belt and loose pulley and if it is V belt between k = 2 and 2.5; if the flat and multiple V-belt is without pulley, it should be between k = 2.5 and = 3.]

Fixed Bearing Standard Design [Axial Force Fa = 0]

Structural size	3000 rpm		1500 rpm		1000 rpm		750 rpm	
	x ₀ (N)	x _{mak} (N)	x ₀ (N)	x _{mak} (N)	x ₀ (N)	x _{mak} (N)	x ₀ (N)	x _{mak} (N)
63	265	235	345	300	-	-	-	-
71	410	350	520	440	620	520	670	570
80	480	400	625	515	730	600	810	670
90	730	610	925	770	1080	900	1210	1000
100	1035	835	1315	1055	1525	1230	1690	1370
112	1030	840	1290	1045	1510	1240	1690	1380
132	1500	1200	1940	1530	2250	1780	2490	1990
160	2800	2230	3340	2610	3740	2890	3740	2890
180	3240	2240	3530	2810	4040	3210	4480	3550
200	4295	3550	5440	4500	6230	5150	6910	5690
225	4770	3970	6025	4800	6890	5510	7640	6110
250	5805	4725	7335	6010	8410	6860	-	-
280	5775	4790	7855	6605	9030	7590	-	-
315	6000	5090	8750	7260	9900	8210	-	-
355	6700	5800	10400	8620	12300	10100	13700	11300

Cylindrical Roller Bearing Special Design [Axial Force Fa = 0]

Structural size	3000 rpm		1500 rpm		1000 rpm		750 rpm	
	x ₀ (N)	x _{mak} (N)	x ₀ (N)	x _{mak} (N)	x ₀ (N)	x _{mak} (N)	x ₀ (N)	x _{mak} (N)
180	7725	6265	9545	7750	10810	8800	11790	9570
200	10580	8720	13050	10750	14660	12160	16070	13270
225	12610	10510	15590	12390	17590	13090	19280	15380
250	16690	13690	20680	16880	23420	19120	-	-
280	16780	14180	22080	16580	24970	20980	-	-
315	18050	15550	29000	23750	32650	26850	-	-
355	23500	20200	26100	21500	29700	24500	32600	26900

Cylindrical Roller Bearing Standard Design

Str. Size	HORIZONTAL SHAFT				VERTICAL SHAFT											
	Pull	Push			Shaft Down						Shaft Up					
		Maks.Fr			Force Down			Force Up			Force Down			Force Up		
	Fr=0	Xo	Xm	Fr=0	Maks.Fr		Fr=0	Maks.Fr		Fr=0	Maks.Fr		Fr=0	Maks.Fr		Fr=0
N	N	N	N	Xo	Xm	N	Xo	Xm	N	Xo	Xm	N	Xo	Xm	N	
2 pole [3000 rpm]																
180	2840	2420	1800	2840	1770	1350	2570	2700	2070	3300	1970	1350	2570	2700	2070	3300
200	3730	3180	2400	3730	2590	1810	3370	3540	2750	4310	2590	1810	3370	3540	2750	4310
225	4180	3510	2620	4180	2800	1900	3750	3950	3050	4900	2800	1900	3750	3950	3050	4900
250	5030	4180	2910	5030	3230	1950	4440	4780	3490	5990	3230	1950	4440	4780	3490	5990
280	5210	4110	2980	4680	3260	2120	4360	4970	3820	6070	2730	1580	3830	5500	4360	6600
315	5210	5040	3940	5210	2800	1680	3820	6450	5330	7460	2800	1680	3820	6450	5330	7460
355	5670	5660	4620	5670	2150	690	3270	8470	7020	9600	—	—	—	—	—	—
4-pole [1500 rpm]																
180	3780	3220	2410	3780	2670	1850	3460	3550	2730	4330	2670	1850	3460	3550	2730	4330
200	4970	4220	3200	4970	3550	2520	4570	4630	3600	5650	3550	2520	4570	4630	3600	5650
225	5550	4680	3280	5550	3740	2330	4990	5240	3830	6490	3740	2330	4990	5240	3830	6490
250	6670	5570	3910	6670	4370	2690	5960	6300	4630	7890	4370	2690	5960	6300	4630	7890
280	7130	6230	4660	7130	4470	3160	6070	7300	5990	8900	4470	3160	6070	7300	5990	8900
315	7870	7370	5250	7870	3940	1800	5780	9490	7350	11330	3940	1800	5780	9490	7350	11330
355	6410	9540	7920	9410	3280	1200	5330	14000	11900	16100	—	—	—	—	—	—
6 pole [1000 rpm]																
180	4480	3810	2870	4480	3200	2250	4120	4170	3210	5090	3200	2250	4120	4170	3210	5090
200	5840	4980	3800	5840	4170	2970	5360	5470	4270	6660	4170	2970	5360	5470	4270	6660
225	6530	5560	3930	6530	4360	2710	5830	6270	4620	7740	4360	2710	5830	6270	4620	7740
250	7890	6610	4670	7890	5200	3240	7060	7450	5490	9310	5200	3240	7060	7450	5490	9310
280	8420	7350	5490	8420	5400	3520	7260	8520	6640	10430	5400	3520	7260	8520	6640	10430
315	9200	8770	6300	9200	4470	1950	6630	11330	8860	13530	4470	1950	6630	11330	8860	13530
355	11100	11300	9300	11100	4540	2110	6940	15900	13400	18300	—	—	—	—	—	—
8 pole [750 rpm]																
180	5030	4290	3230	5030	3610	2550	4640	4680	3610	5710	3610	2550	4640	4680	3610	5710
200	6600	5610	4280	6600	4790	3450	6130	6090	4750	7430	4790	3450	6130	6090	4750	7430
225	7390	6210	4400	7390	5110	3270	6750	6860	5020	8510	5110	3270	6750	6860	5020	8510
250	8830	7400	5250	8830	5860	3690	7940	8300	6130	10430	5860	3690	7940	8300	6130	10430
280	9540	8240	6170	9540	6340	4240	8430	9370	7270	11530	6340	4240	8430	9370	7270	11530
315	10430	9790	7030	10430	5470	2660	7890	12330	9570	14830	5470	2660	7890	12330	9570	14830
355	12700	12800	10300	12700	5830	3120	8510	17200	14400	19800	—	—	—	—	—	—

Permissible Axial External Forces

Shaft End

Standard motors have only one cylindrical shaft end and they comply with the standard EN 50347 [IEC 60072-1]. Key seat in sizes specified in the standard is gained on motor shaft and shipped as key installed. Shaft end is threaded compatible with DIN 332-2. The second shaft end can be provided with additional costs.

Shaft end runout, the concentricity of the flange face and steepness of surface are in compliance with EN 50347 [IEC 60 072-1]. Increased accuracy – tolerance R [reduced] can be provided, if requested.

I-MAK Motors has the capability to manufacture all kinds of special motors on request.

Vibration

All rotors are balanced dynamically with half keys compatible with DIN EN 60 034-14/A1. Because of that, the balance of any driving element to be mounted on the shaft (rotors,gears, couplers etc) should be executed with a half key mounted mandrel.

Active Vibration Severity Limits in mm/sec with Shaft Height H [mm]

Adjustment	Speed range rpm	Limit values for the vibration speeds for the following structural sizes at		
		63<H<132	132<H<225	250<H<400
N [normal]	600-3600	1.8	2.8	3.5
	600-1800	0.71	1.12	1.8
R [reduced]	1801-3600	1.12	1.8	2.8
	600-1800	0.45	0.71	1.12
S [special]	1801-3600	0.71	1.12	1.8

* There may be $\pm 10\%$ difference between the calculated and the actual values.

SOUND [NOISE] LEVELS

Noise measurement of standard **HMAK** motors is carried out in a sound proof room as specified in the standard TS EN 60034-9/A1. There are three factors causing noise: magnetic forces, bearings and cooling fan.

Magnetic forces: It is caused by vibration of the stator.

Bearings: Noises that occur in balls and rollers.

Cooling fan: Noise caused by the air flow.

The most active of the three main sources of noise the noise from cooling fan.











The values indicated in the table below are the values specified in the 50 Hz mains frequency. About 4 dB [A] should be added to these values to find the values for 60 Hz.







Surface – Sound pressure level LPA



Size of Structure	2-pole dB [A]	4-pole dB [A]	6-pole dB [A]	8-pole dB [A]
63	51	43	-	-
71	58	46	43	43
80	60	50	46	44
90	63	52	52	50
100	65	55	54	53
112	66	57	55	54
132	70	61	59	57
160	74	65	63	62
180	75	67	65	63
200	75	67	65	63
225	77	69	67	65
250	79	71	69	67
315	82	76	73	-
355	82	76	73	-

All the data recorded for the LpA may vary ± 3 dB [A].

CONSTRUCTION TYPES AND MOUNTING ARRANGEMENTS [TS 3211 EN 60034-7]

Symbol	Connection Type	No Flange	Description	Construction Size
IM B3 / IM 1001			Floor Mounted	All
IM B6 / IM 1051, IM B7 / IM 1061, IM B8 / IM 1071				All
IM V5 / IM 1051 No Rain Protection			Wall Mounted, shaft end facing downward	All
IM V6 / IM 1031			Wall Mounted, shaft end facing upward	All
IM V5 / IM 1031 With rain protection			shaft end facing downward	All
Symbol	Connection Type	Flange (B5)	Description	Construction Size
IM B5 / IM 3001			Flange Mounted	All
IM V1 / IM 3011 IM V15 / IM 2011 No Rain Protection			Wall Mounted, shaft end facing downward	All
IM V1 / IM 3011 With rain protection			Flange Mounted, shaft end facing	All
IM V3 / IM 3031			Wall Mounted, shaft end facing upward	All
IM B35 / IM 2001			Floor Mounted. Flange connected	All

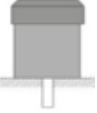
Symbol	Connection Type	Standard Flange [B14]	Description	Construction Size
IM B14 / IM 3601			Flange Mounted	All
IM V18 / IM 3611 IM V58 / IM 2111 No Rain Protection		Flange Mounted	 Flange. Shaft end facing downward	All
IM V18 / IM 3611 With rain protection			Flange Mounted, shaft end facing	All
IM V19 / IM 3631 IM V69 / IM 2131		Flange Mounted	 Shaft end facing upward	All
IM B34 / IM 2101			Floor Mounted. Flange connected	All

Symbol	Connection Type	Standart Flaşlı [B14]	Description	Construction Size
IM B9 / IM 9101			Front Mounted	All
IM V8 / IM 9111			No feet, no cap, mounted by front of the frame Shaft end facing downward	All
IM V9 / IM 9131			No feet, no cap, mounted by front of the frame Shaft end facing upward	All
IM B15 / IM 1201			No front cap, foot mounted	All

VOLTAGE AND FREQUENCY

As a standard practice, motors are designed according to 400V voltage and 50Hz frequency. In line with customer requirements, they can be produced in the range of 42-690 V voltage range and 50-60 Hz frequency range. No change in the power of the motor is observed during $\pm 5\%$ variation in the voltage and $\pm 2\%$ variation in the frequency.

Temperature of motors operating continuously in the upper and lower voltage values can exceed 10K over the maximum permissible temperature rise depending on the winding insulation class [B:80K, F:100K H:125K].

When motors designed for 50 Hz frequency is operated at 60 Hz network, to detect electrical values they should be multiplied with the following coefficients.

50 Hz		60 Hz							
Rated Voltage V	Network Voltage V	Full Load Operating Specifications							
		Power	Speed	In	Io	Ia/In	Mn	Ma/Mn	Mk/Mn
230	230	1	1.2	1	0.73	0.87	0.83	0.75	0.85
	250	1.1	1.2	1	0.85	0.96	0.91	0.83	0.94
	264	1.15	1.2	1	0.93	1	0.96	0.93	1
	278	1.2	1.2	1	0.98	1.03	1	0.96	1.03
400	400	1	1.2	1	0.73	0.87	0.83	0.75	0.85
	440	1.1	1.2	1	0.85	0.96	0.91	0.83	0.94
	460	1.15	1.2	1	0.93	1	0.96	0.93	1
	480	1.2	1.2	1	0.98	1.03	1	0.98	1.03
500	500	1	1.2	1	0.73	0.87	0.83	0.75	0.85
	550	1.1	1.2	1	0.85	0.96	0.91	0.83	0.94
	575	1.15	1.2	1	0.93	1	0.96	0.93	1
	600	1.2	1.2	1	0.98	1.03	1	0.98	1.03

Up to 20% increase in power can be observed at motors designed as 60 Hz.

Standard Power [kW] 50 Hz	Standard Power [kW] 60 Hz	Standard Power [kW] 50 Hz	Standard Power [kW] 60 Hz	Standard Power [kW] 50 Hz	Standard Power [kW]
0.09	0.108	2.2	2.64	30	36.0
0.12	0.144	3	3.40	37	44.4
0.18	0.216	4	4.8	45	54
0.25	0.30	5.5	6.6	55	66
0.37	0.444	7.5	9.0	75	90
0.55	0.66	11	13.2	90	108
0.75	0.90	15	18.0	110	132
1.1	1.32	18.5	22.2	132	158
1.5	1.80	22	26.4	160	192

RATED POWER

The rated power of the motor is referred to as mechanical power obtained from the motor shaft at nominal current and voltage values printed on the label of the motor.

Electrical power (Pe); is the power drawn from the mains and is greater than the mechanical power obtained from the motor shaft due to losses.

$$P_e = \sqrt{3} \cdot U \cdot I \cdot \cos \varphi$$

The efficiency of the motors (η) refers to the ratio of the mechanical power obtained from the motor shaft with electrical power drawn from the mains. Efficiency rates printed in the motor catalogue are calculated by the method specified in TSI EN 60034-2-2.

Electrical values specified in motor catalogue are valid at ambient temperature of 25 °C, altitude up to 1000 and continuous operation (S1) and does not include the special operation conditions. In applications where temperature and altitude values are not met power obtained from motor shaft varies as indicated in the tables.

Temperature [Pn] effect;

Ambient Temperature	°C	≤30	40	45	50	55	60
P _N	%	110	100	95	90	85	80

Temperature [Pn] effect;

Height	m	1000	2000	3000	4000
(P _N)	%	100	95	90	80

Under circumstances where both altitude and ambient temperature change at the same time, new nominal power coefficient will be obtained by multiplying corresponding coefficients.

When the ambient temperature is in the range of 30–40 °C in motors operating at altitudes over 1000 m, the power obtained from the motor shaft will not change if a reduction of 1 °C in temperature for insulation class F and 1.25 °C for insulation class H at increases of height every 100m.

OVERLOAD

If 1.5 times of the rated current passes through the coils for a period of maximum 2 minutes with intervals of 15 minutes while a standard **I-MAK** is running in a regime temperature, the temperature rise at a level that will damage the winding will not occur. In addition, the motor is manufactured to withstand 1.6 times excessive torque of the nominal torque for 15 seconds when running at nominal voltage and frequency.

Outside this periods of time, the load of motor depends upon factors such as overcurrent and excessive torque values applied, the operating conditions of the motor, the application duration, frequency of the load or current , motor's being at regime temperature.

RATED TORQUE

The torque in Nm [Newton-meters] from motor shaft is expressed as follows:

$$M = \frac{9,55 \cdot P_N \cdot 1000}{n}$$

P_N: Nominal output power in kW

N: the nominal speed in terms of rpm

1 kgfm = 9.81 Nm ≈ 10 Nm

INSULATION CLASS

We produce standard motors with class F insulation.

As defined in the standards, permissible temperature rise limit for Class F is 105K. We produce motors to operate within limits of Class B [80K] to improve both the performance and lifetime. In such a motor designed in this way, the maximum level in the ambience temperature is elevated and the power factor is drawn upwards.

For example, operating ambient temperature of a motor produced as Class F and designed at class F temperature rise limit must be 40 °C at a maximum. Operating ambient temperature of a motor produced as Class F and designed at class B temperature may rise up to -40 °C at a maximum. Similarly, I-MAK motors produced as class F and and designed at class B temperature rise limit can exceed the nominal power 10% - 15% and show a better performance against network fluctuations.

Enamelled copper wire used as a standard is supplied in class H [180 °C].

To maximize the thermal conductivity of motor windings and to prevent the vibration of the motor windings, it is used with synthetic and water based varnish in class H, and then oven-dried.

OPERATION DUTY

Operation duties are as described in TS EN 60034-1. Modes of operation are expressed by abbreviations through S1-S10. The operating regime in operational type S4, S5 and S7 is an operating program that includes the application periods and orders of loads applied to the motor as well as start and stop periods of motor without load.

Electric motors are produced according to a wide range of operating conditions. Standard operation duty is described in IEC 60034 -1.

Symbol	Description	Example
S1	Continuous Operation Operating of the motor under constant load until it reaches a thermal equilibrium. Short-Time Duty	S1
S2	Short-Time Duty Operating of motor at constant load for a shorter period of time which is less than the time required to reach thermal equilibrium in sufficient time so as a period of no energy and rest follow in order to be able to keep the motor's temperature within coolant temperature of 2 K.	S2 - 60 dak
S3	Periodic Intermittent Duty A sequence of identical cycles without a thermal steady state being reached. Each cycle is composed of a time with constant loading and a pause. In this duty, the starting current should have practically no effect on the increase in temperature.	S3 - %25
S4	Periodic Intermittent Duty with influence of the start-up process It can be defined as a sequence of identical cycles without a thermal steady state being reached. Each cycle is composed of a noticeable starting time, a time with constant loading and a pause. S4 is followed by cyclic period factor and moment of inertia of the motor and moment of inertia of the load [J_{ext}], both of which belong to motor shaft.	S4 - %25 $J_M = 0,15 (kgxm^2)$ $J_{ext} = 0,7 (kgxm^2)$
S5	Periodic Intermittent Duty with Electrical Braking It can be defined as a sequence of identical cycles without a thermal steady state being reached. Each cycle is composed of a noticeable starting time, a time with constant loading, electrical breaking period, resting and a pause. S5 is followed by cyclic period factor and moment of inertia of the motor [J_m] and moment of inertia of the load [J_{ext}], both of which belong to motor shaft.	S5 - %25 $J_M = 0,15 kgxm^2$ $J_{ext} = 0,7 kgxm^2$
S6	Continuous Periodic Operation It can be defined as a sequence of identical cycles without a thermal steady state being reached. Each cycle is composed of a starting time, a time with constant loading and a no-load operating time. There is no pause in this mode	S6 - %40
S7	Uninterrupted Periodic Duty with Electrical Braking A sequence of identical cycles. Each cycle is composed of a starting time, a time with constant loading and a time with electrical braking. There is no pause in this mode of operation.	S7 $J_M = 0,4 kgxm^2$ $J_{ext} = 7,5 kgxm^2$
S8	Uninterrupted Periodic Duty With Load/Speed Changes A sequence of identical cycles following each other [different speeds such as double speed motors]. Each cycle is composed of a time with constant loading and a particular speed and one ore more times with other loadings at different speeds. There is no pause in this mode of operation. The figure S8 is followed by cyclic period factor and moment of inertia of the motor [J_m] and moment of inertia of the load [J_{ext}], both of which belong to motor shaft and load, speed and cyclic period factor at every speed condition.	S8 $J_M = 0,5 kgxm^2$ $J_{ext} = 6 kgxm^2$ 16 kW 740 $enaz^{-1}$ %30 40 kW 1460 $enaz^{-1}$ %30 25 kW 980 $enaz^{-1}$ %40
S9	Non-Periodic Duty With Load/Speed Changes Loading and speed change non-periodically within the permissible operating range. Motor operates above nominal power can occur. Overloading can occur. Load and inertia moment coefficients at various speeds should be provided.	S9
S10	Duty With Discrete Constant Loads Operating mode that does not include more than 4 particular load values, wherein every value is kept for a period sufficient for the motor to reach thermal equilibrium.	S10

N: Operating under nominal conditions
D: Starting

F: Electrical braking
R: Stop

V: Idling
S: Operating overload

L: operating with variable load
Cp: Full load

Relative period of duty It is defined as the proportion of duty with load to total period of duty. Start-up and electrical breaking periods are included in the period of duty.

$$\text{Inertia moment coefficient} = \frac{J_M / J_Z}{J_M}$$

J_M Inertia moment of motor [kgm^2]

J_Z Total inertia moment of heavy equipment such as pump, fan vb. and fittings like couplings as compared to motor shaft [kgm^2]

Type of braking, whether mechanical or electrical, should be noted

The value of duty provided in the catalogue belongs to continuous operation [S1]. Motors we produce as standard SI can operate in other modes of operation not to exceed the maximum temperature values.

FREQUENCY OF START-UP

When asynchronous motors start-up too often, the incoming heat from start-up limits the number of start-ups. Frequency of permissible no-load start-ups in an hour is indicated in the following table. The number of start-ups which an asynchronous motor can make an hour depends on the operating conditions and calculated by the following formula

$$Z = \frac{J_M}{J_M + J_Z} \cdot \frac{M_M - M_L}{M_M} \cdot \left[1 - \left(\frac{P}{P_N} \right)^2 \right] Z_0$$

- Z : Starting frequency per hour of operating conditions
- Z_0 : Starting frequency per hour of no-load operating conditions
- J_M : Inertia moment of motor [kgm^2]
- J_Z : inertia of components such as heavy equipment as compared to the motor shaft
- M_M : The motor's torque during acceleration [Nm]
- M_L : The heavy equipment's torque during acceleration [Nm]
- P_N : Motor rated power [kW]
- P : Power required by the heavy equipment [kW]

If the asynchronous motor frequently starts and stops in operating conditions the motor power needed to be selected should be calculated according to the following formula, as the needed motor power [P] and the nominal motor power P_N

$$P = P_N \sqrt{1 - \frac{Z}{Z_0} \cdot \frac{J_M + J_Z}{J_M} \cdot \frac{M_M}{M_M - M_L}}$$

For HMAK electric motors M can be taken as 2 times the nominal torque in the calculation.

Change of electrical direction can cause the motor 3-4 times more warming as compared to start up. Therefore, the frequency of the permissible cyclic shifts per hour is to be calculated as the 1/4 of start frequency. Load torque [ML] should be taken into account with calculation of changes in direction.

Permissible starting frequency at idling Z_0 is available in the table below.

Permissible starting frequency per hour at no-load operation [Z0]

Building Size		Motor speed (rpm)			
		3000	1500	1000	750
63	M	30000	48000		
71	M	14700	20700	31000	34000
80	M	9300	18000	28500	32500
90	S	9000	17100	26200	31600
	L	8800	16500	24200	31700
100	L	6400	11000	13800	18800
112	M	3300	9200	12800	12800
132	S	2000	4900	9800	12100
	M	-	4750	7850	10350
160	M	950	2950	4050	-
	L	900	2850	3550	8950
180	M	600	2100	-	-
	L	-	2000	3400	6600
200	L	470	1950	3100	3800
225	S	-	1850	-	-
	M	420	1770	2200	3300
250	M	330	980	1820	2320
280	S	220	720	1420	1820
	M	200	680	1130	1680
315	S	110	400	650	750
	M	90	350	560	670
	L	70	300	450	550
355	M/L	50	160	250	300

Start Duration

All values of torque of asynchronous motor for a secure start, from start until it reaches the nominal speed, must be greater enough than the load torque of the machine.

Starting torque of the motor must be greater than the load torque of the machine in the state of being at rest. Motors of particularly high starting torque can be produced.

Starting time is an important parameter of the electrical motor. Motors become warmer because they draw more current than normal during start-up. It is necessary to limit the duration and frequency of start-up to prevent damage to motors. Starting time is calculated according to the formula below.

$$t_a = \frac{(J_M + J_Z) \cdot n}{9,55 \cdot (M_M - M_L)}$$

t_a : Starting time [s]

J_M : Inertia moment of motor [kgm²]

J_Z : inertia of components such as heavy equipment as compared to the motor shaft

M_M : The motor's torque during acceleration [Nm]

M_L : The heavy equipment's torque during acceleration [Nm]

n : Nominal motor speed [rpm]

Start-up times calculated from this formula must be smaller than the start-up times in the table. Permissible starting times vary depending on whether the motor is cold and at thermal equilibrium. Motors can start three consecutive times when cold and twice when at the operating temperature. The motor should adequately cool down for the next start. This period is approximately 30 minutes.

Structure Size	3000 rpm		1500 rpm		1000 rpm		750 rpm	
	Cold	Business	Cold	Business	Cold	Business	Cold	Business
63	70	28	100	45				
71	50	20	75	30	140	55	140	55
80	40	15	60	25	90	35	90	35
90	35	13	50	20	65	25	65	25
100	32	12	40	17	50	20	50	20
112	30	11	35	14	40	16	40	16
132	28	10	30	12	32	13	32	13
160	26	9	27	10	28	10	28	10
180	24	8	25	9	25	9	25	9
200	22	8	23	8	23	9	23	9
225	20	7	21	8	22	8	22	8
250	19	7	20	7	21	8	21	8
280	18	6	19	7	20	7	20	7
315	18	6	18	6	19	7	19	7
355	16	5	16	5	17	6	17	6

Periods in Δ/Y start should be multiplied by about 3.

TERMINAL CONNECTION AND STARTING METHODS

For standard productions, 400 V Δ connection is made for 2 and 4 pole at power values 4kW and over; 400 V Δ for 6 pole at power values 3 kW and and over and 400 V Δ for 8 pole at power values of 3kW and over. For power values less than these 400 VY connection is made.

Number of Poles	230/400 V Δ/Y	400/690 V Δ/Y
2 ve 4	≤ 3 kW	≥ 4 kW
6	≤ 2.2 kW	≥ 3 kW
8	≤ 1,5 kW	≥ 2.2 kW
Starting Methods	Direct	Direct [not recommended] Y/ Δ or other

Δ CONNECTION

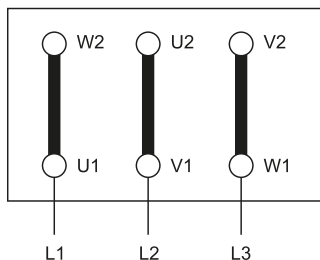

Y CONNECTION

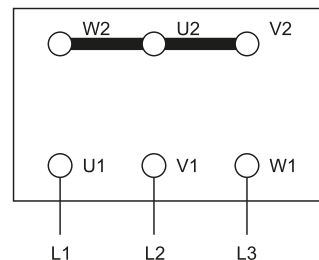

U-V-W ▪ Motor Phases

L1-L2-L3 ▪ Phases of Energy

DIRECT STARTING

The easiest and cheapest way for a squirrel cage asynchronous motor is to connect directly to mains voltage. This method has the advantage of being low operating costs compared to other methods. However, it has the disadvantages of drawing more current from the mains and causing more consumption and windings are forced because of starting currents.

INDIRECT STARTING

In cases where starting current of motors exceed limit values of network, star-delta starting may be used to limit the current. Starting a motor designed as 400 V Δ by triangle connection, starting current and starting torque are reduced. Because phase-neutral voltage instead of phase-to-phase voltage is supplied to the motor terminals, voltage decreases 3 times, the current and torque decrease 3 times.

Among the advantages are a solution simple, small in size, low in power and inexpensive, low starting current as compared to direct starting? It has the disadvantages of starting characteristics which cannot be adjusted, long time of starting because the moment decreases, sudden passes of moment and current while passing from delta to star, open circuit, non-inclusion of motor protection parameters and having 6 cable connections to the motor.

In star-delta starting, star-delta times should be calculated well. Transition from star to delta should occur when 95% of the nominal motor speed is reached.

SOFT STARTING

Soft starters are the most advanced starting mode in the starters lowering the voltage. In addition to advanced motor protection and operator interface specifications, they can control current and torque in an excellent way.

The main advantages that soft starters provide are as follows;

- 1- During the start-up, current and the torque are controlled in a flexible and simple way,
- 2- Voltage and current can be supplied continuously and without exposure to sudden changes,
- 3- It is appropriate for frequent starting,
- 4- Works for variable start-ups conditions,

Electrical Protection of Motors

Winding temperature in the motor must be observed to avoid winding temperatures to exceed the specified values by insulation class used in motors. Insulation class must be selected taking into account the operating conditions.

Generally, motors are tried to be protected by connecting the overload relays and delayed overcurrent protection breakers. Such protection protects the motor at only start up. However, during runtime, the winding temperature increases due to load, voltage and frequency changes and windings are unprotected. Thermal protector and a thermistor must be applied in order to monitor temperature increases occurring in the windings and to deactivate the motor at the maximum value the motor winding insulation allows. This is the most reliable method. Fuses built into the system do not mean anything in terms of motor protection and protects only the system.

PERFORMANCE VALUES

3 PHASE
 VOLTAGE : 400 V.
 FREQUENCY : 50 Hz.
 PROTECTION CLASS : IP 55
 INSULATION CLASS : F
 MODE OF OPERATION : S1

Aluminium Frame – Synchronous Speed 750 d/dk [8 pole]

Δ 230 / Y 400 V

TYPE AB	Rated Power		Nominal Speed rpm	Nominal Current 400 V A	Nominal Moment Nm	Starting Values				Overturning Moment Nom-Mom M _s /M _n	Efficiency % η	Power Factor Cosφ	Moment of Inertia kgm ²	Footed Motor Weight Kg.
	kW	HP				Current I _s /I _n		Moment M _s /M _n						
						λ	Δ	λ	Δ					
80 M8A	0.18	1/4	675	0.79	2.5	2.3	-	1.8	-	1.8	50	0.60	0.0015	8
80 M8B	0.25	1/3	670	1.00	3.5	3.0	-	1.9	-	1.9	55	0.60	0.0018	9
90 S8A	0.37	1/2	665	1.30	5.3	3.3	-	1.6	-	1.6	59	0.70	0.0028	12
90 L8A	0.55	3/4	665	1.74	7.9	3.2	-	1.6	-	1.6	56	0.70	0.0035	14.3
100 L8A	0.75	1	670	2.28	11	3.9	-	1.5	-	1.7	65	0.65	0.0063	18.5
100 L8B	1.1	1.5	660	3.40	16	4.1	-	1.7	-	1.8	65	0.65	0.011	20
112 M8A	1.5	2	690	4.45	21	4.5	-	1.5	-	1.7	65	0.62	0.020	23

Aluminium Frame – Synchronous Speed 750 d/dk [8 pole]

Δ 400 / Y 690 V

TYPE AB	Rated Power		Nominal Speed rpm	Nominal Current 400 V A	Nominal Moment Nm	Starting Values				Overturning Moment Nom-Mom M _s /M _n	Efficiency % η	Power Factor Cosφ	Moment of Inertia kgm ²	Footed Motor Weight Kg.
	kW	HP				Current I _s /I _n		Moment M _s /M _n						
						λ	Δ	λ	Δ					
132 S8A	2.2	3	700	6.2	30	1.1	3.3	-	1.6	1.9	70	0.66	0.028	33
132 M8A	3	4	695	8.1	41	1.2	3.5	-	1.8	1.9	75	0.70	0.035	36
160 M8A	4	5.5	700	10.4	55	1.2	3.7	-	1.6	1.9	75	0.65	0.052	65
160 M8B	5.5	7.5	710	14.3	74	1.3	3.8	-	1.7	2.0	77	0.65	0.055	74
160 L8A	7.5	10	705	18.6	102	1.3	3.8	-	1.7	1.9	77	0.70	0.080	94

Cast Iron Frame–Synchronous Speed 750 d/dk [8 pole]

Δ 400 / Y 690 V

TYPE AB	Rated Power		Nominal Speed rpm	Nominal Current 400 V A	Nominal Moment Nm	Starting Values				Overturning Moment Nom-Mom M _s /M _n	Efficiency % η	Power Factor Cosφ	Moment of Inertia kgm ²	Footed Motor Weight Kg.
	kW	HP				Current I _s /I _n		Moment M _s /M _n						
						λ	Δ	λ	Δ					
132 S8A	2.2	3	700	6.2	30	1.1	3.3	-	1.6	1.9	70	0.66	0.028	44
132 M8A	3	4	695	8.1	41	1.2	3.5	-	1.8	1.9	75	0.70	0.035	52
160 M8A	4	5.5	700	10.4	55	1.2	3.7	-	1.6	1.9	75	0.65	0.052	80
160 M8B	5.5	7.5	710	14.3	74	1.3	3.8	-	1.7	2.0	77	0.65	0.055	89
160 L8A	7.5	10	705	18.6	102	1.3	3.8	-	1.7	1.9	77	0.70	0.080	114
180 L8A	11	15	720	24.1	145	1.7	5.0	-	2.0	2.2	81	0.80	0.25	172
200 L8A	15	20	730	34	196	1.8	5.8	-	2.0	2.6	89	0.77	0.24	260
225 M8A	22	30	730	46.5	290	1.9	5.9	-	2.0	2.6	89.5	0.80	0.78	340
250 M8A	30	40	736	67	390	1.7	5.2	-	2.3	2.1	91	0.70	0.90	410

HIGH EFFICIENCY MOTORS

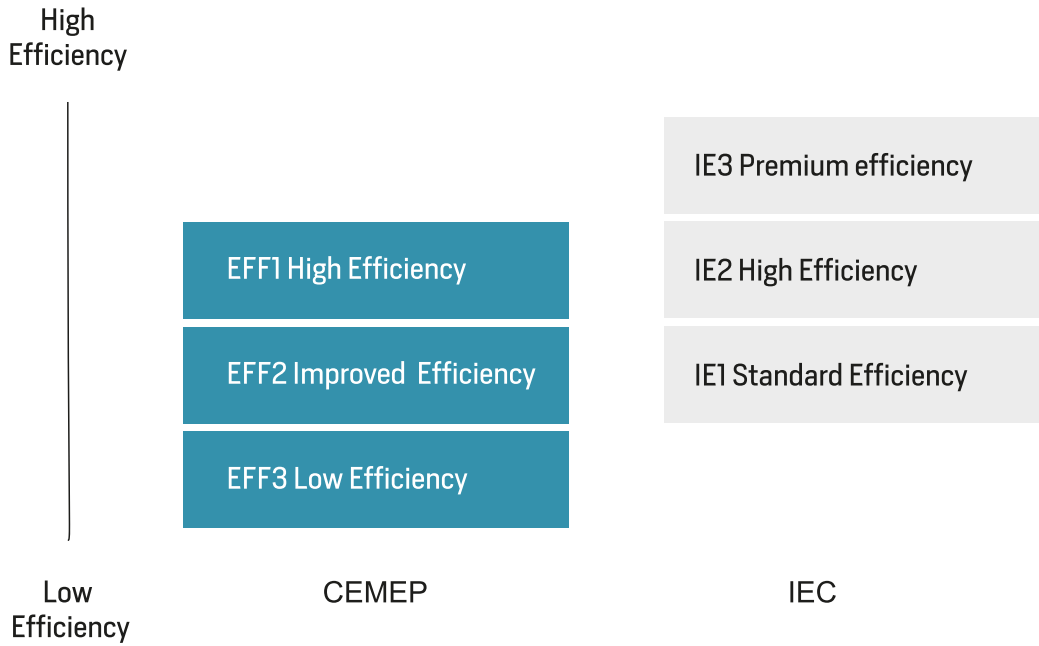

	CEMEP	IEC
		IEC 60034-30-1:2014
Power range	1,1-90 kW	0,12-1000 kW
Pole	2-4	2-4-6-8

Another difference between CEMEP and IEC 60034-1:2014 is the calculation method of the motor efficiency. IEC 60034-2:1996 standard is replaced by IEC 60034-2-1:2007 standard.

The new standard, which is used calculate the additional losses, uses more precise measurement and calculation methods to determine losses and efficiency of the electric motors. The measurement methods specified in both standards are as follows:

Old Testing Standard IEC 60034-2:1996	New Testing Standard IEC 60034-2-1:2007
<p>Direct measurement method</p>	<p>Direct measurement method</p>
<p>Indirect measurement method Additional losses [PLL] are taken into account as 0.5% of the input power at full load.</p>	<p>Indirect measurement method Additional losses [PLL] are determined according to the results of the tests carried out in different load values. Additional losses [PLL] are taken into account at rates ranging from 1% to 2.5% of the input power for motors from 1 kW up to 1000 kW. Additional losses [PLL] are based on mathematical calculations.</p>
<p>Stator and rotor winding losses are determined by a temperature of 95 °C.</p>	<p>Stator and rotor winding losses are determined according to [25 °C + measured temperature increase value].</p>

Performance Values

The lower limit values of 50 and 60 Hz new IE1, IE2 and IE3 efficiency classes are as indicated in the following table.

50 Hz Efficiency Values

P_N (kW)	IE1			IE2			IE3		
	Number of poles								
	2	4	6	2	4	6	2	4	6
0.75	72.1	72.1	70.0	77.4	79.6	75.9	80.7	82.5	78.9
1.1	75.0	75.0	72.9	79.6	81.4	78.1	82.7	84.1	81.0
1.5	77.2	77.2	75.2	81.3	82.8	79.8	84.2	85.3	82.5
2.2	79.7	79.7	77.7	83.2	84.3	81.8	85.9	86.7	84.3
3	81.5	81.5	79.7	84.6	85.5	83.3	87.1	87.7	85.6
4	83.1	83.1	81.4	85.8	86.6	84.6	88.1	88.6	86.8
5.5	84.7	84.7	83.1	87.0	87.7	86.0	89.2	89.6	88.0
7.5	86.0	86.0	84.7	88.1	88.7	87.2	90.1	90.4	89.1
11	87.6	87.6	86.4	89.4	89.8	88.7	91.2	91.4	90.3
15	88.7	88.7	87.7	90.3	90.6	89.7	91.9	92.1	91.2
18.5	89.3	89.3	88.6	90.9	91.2	90.4	92.4	92.6	91.7
22	89.9	89.9	89.2	91.3	91.6	90.9	92.7	93.0	92.2
30	90.7	90.7	90.2	92.0	92.3	91.7	93.3	93.6	92.9
37	91.2	91.2	90.8	92.5	92.7	92.2	93.7	93.9	93.3
45	91.7	91.7	91.4	92.9	93.1	92.7	94.0	94.2	93.7
55	92.1	92.1	91.9	93.2	93.5	93.1	94.3	94.6	94.1
75	92.7	92.7	92.6	93.8	94.0	93.7	94.7	95.0	94.6
90	93.0	93.0	92.9	94.1	94.2	94.0	95.0	95.2	94.9
110	93.3	93.3	93.3	94.3	94.5	94.3	95.2	95.4	95.1
132	93.5	93.5	93.5	94.6	94.7	94.6	95.4	95.6	95.4
160	93.8	93.8	93.8	94.8	94.9	94.8	95.6	95.8	95.6
200–375	94.0	94.0	94.0	95.0	95.1	95.0	95.8	96.0	95.8

60 Hz Efficiency Values

P_N (kW)	IE1			IE2			IE3		
	Number of poles								
	2	4	6	2	4	6	2	4	6
0.75	77.0	78.0	73.0	75.5	82.5	80.0	77.0	83.5	82.5
1.1	78.5	79.0	73.5	82.5	84.0	85.5	84.0	86.5	87.5
1.5	81.0	81.5	77.0	84.0	84.0	86.5	85.5	86.5	88.5
2.2	81.5	83.0	78.5	85.5	87.5	87.5	86.5	89.5	89.5
3.7	84.5	85.0	83.5	87.5	87.5	87.5	88.5	89.5	89.5
5.5	86.0	87.0	85.0	88.5	89.5	89.5	89.5	91.7	91.0
7.5	87.5	87.5	86.0	89.5	89.5	89.5	90.2	91.7	91.0
11	87.5	88.5	89.0	90.2	91.0	90.2	91.0	92.4	91.7
15	88.5	89.5	89.5	90.2	91.0	90.2	91.0	93.0	91.7
18,5	89.5	90.5	90.2	91.0	92.4	91.7	91.7	93.6	93.0
22	89.5	91.0	91.0	91.0	92.4	91.7	91.7	93.6	93.0
30	90.2	91.7	91.7	91.7	93.0	93.0	92.4	94.1	94.1
37	91.5	92.4	91.7	92.4	93.0	93.0	93.0	94.5	94.1
45	91.7	93.0	91.7	93.0	93.6	93.6	93.6	95.0	94.5
55	92.4	93.0	92.1	93.0	94.1	93.6	93.6	95.4	94.5
75	93.0	93.2	93.0	93.6	94.5	94.1	94.1	95.4	95.0
90	93.0	93.2	93.0	94.5	94.5	94.1	95.0	95.4	95.0
110	93.0	93.5	94.1	94.5	95.0	95.0	95.0	95.8	95.8
150	94.1	94.5	94.1	95.0	95.0	95.0	95.4	96.2	95.8
185 and above	94.1	94.5	94.1	95.4	95.4	95.0	95.8	96.2	95.8

The efficiency value has a tolerance up to $[(100 - \text{efficiency}) \times 0.15]$. So, if the efficiency value obtained as a result of actual engine test results is lower than the specified IE limit as this tolerance, then it is accepted in the specified efficiency class.

High efficiency motors have the same mechanical properties as standard engines. They are also in compliance with the same standards and the norms. IMAK motors are painted with RAL 5023 [DIN1843] light blue protective paint.

CALCULATION OF ENERGY SAVINGS FOR HIGH EFFICIENCY MOTORS

In general terms, energy efficiency is directing energy to the expected work and reducing energy losses.

Electric motor efficiency = power received from the motor shaft/ power drawn from the mains
 Power drawn from the mains = power obtained from motor shaft + Losses

Losses occurring in high-efficiency motors [the stator and rotor winding losses, iron losses, losses of friction and ventilation] are lower compared to the standard motors. Therefore, they provide energy savings as long as they work since the power they draw from the mains is lower as compared to low efficiency motors. The following information is needed to calculate energy savings required when analysing preferability of high-efficiency motors to low efficiency motors;

- Rated power and speed of the existing motor [It may be obtained from the label information]
- The efficiency of the existing motor [Please contact us]
- The load percentage of the motor [would be considered 80% if not known.]
- The total annual operating hours of the motors. In light of this information, the total savings is calculated as;

$$K = t \cdot P_N \cdot x \cdot k \cdot \frac{1}{(\eta - \eta_{IE})}$$

K	: Total annual savings	TL
t	: The total annual working hours	H
P_N	: Rated power of the motor	kW
x	: Load ratio of motor [to be taken into account as x = 0.80 if 80%]	-
k	: The unit price of electricity	TL/kWh
η	: Efficiency ratio of motor [to be taken into account as $\eta = 0.87$ if 87%]	-
η_{IE}	: Efficiency value of high-efficiency motor [to be taken into account as $\eta = 0.89$ if efficiency rate is 89%.]	-

After calculating total savings by this formula, how the initial investment costs will depreciate can be calculated. For example;

For a 4 kW, 1500 rpm pump running 7 days 24 hours the unit price of power is 15 cent/kWh, annual energy savings IE2 electric motor will provide compared to IE1 motors can be calculated as follows:

- IE2 electric motor draws $4 / 0.866 = 4.619$ kW power from the power supply and consumes $4.619 \times 24 = 110.86$ kWh energy per day
- IE1 electric motor draws $4 / 0.842 = 4.751$ kW power from the mains and consumes $4.751 \times 24 = 114.02$ kWh energy per day.

Under these conditions, the IE2 electric motor compared with IE1 motor, saves;

- 3.16 kWh of energy,
- $3.16 \times 0.15 = 0.474$ USD
- The annual savings would be \$ 173.

Considering an internationally recognized 4 kW 4-pole IE1 motor's list price of \$ 414 and the list price of IE2 motor of the same power of \$ 482, investment costs of the IE2 motor is expected to pay for itself within a period of time shorter than one year.

IE1

3 PHASE,
 VOLTAGE : 400 V.
 FREQUENCY : 50 Hz.
 PROTECTION CLASS : IP 55
 INSULATION CLASS : F
 MODE OF OPERATION : S1

Synchronous Speed 3000 rpm

Δ 230 / Y 400

TYPE AA	Rated Power		Nom. Speed rpm	Rated Current 400 V A	Nominal Moment Nm	Starting values				Overturning Moment Nom - Mom M _K /M _{NK}	Efficiency			Power Factor Cosφ	Moment of Inertia kgm ²	Footed Motor Weight kg	
	kW	HP				Current		Moment			η	100%	75%				50%
						I _A /I _N λ	I _A /I _N Δ	M _A /M _N λ	M _A /M _N Δ								
63M2A	0.18	1/4	2740	0.50	0.62	4.0	-	2.3	-	2.3	52.8	52.5	52.0	0.81	0.00016	4.0	
63M2B	0.25	1/3	2765	0.68	0.86	4.3	-	2.3	-	2.3	58.2	58.0	57.8	0.81	0.00020	4.5	
71M2A	0.37	1/2	2765	1.02	1.30	4.3	-	2.3	-	2.3	63.9	63.7	63.1	0.79	0.00035	5.5	
71M2B	0.55	3/4	2800	1.44	1.90	4.9	-	2.3	-	2.3	69.0	68.9	68.5	0.81	0.00045	6.4	

Synchronous Speed 1500 rpm

Δ 230 / Y 400

TYPE AA	Rated Power		Nom. Speed rpm	Rated Current 400 V A	Nominal Moment Nm	Starting values				Overturning Moment Nom - Mom M _K /M _{NK}	Efficiency			Power Factor Cosφ	Moment of Inertia kgm ²	Footed Motor Weight kg	
	kW	HP				Current		Moment			η	100%	75%				50%
						I _A /I _N λ	I _A /I _N Δ	M _A /M _N λ	M _A /M _N Δ								
63M4A	0.12	1/6	1315	0.42	0.88	3.0	-	1.9	-	2.0	50.0	49.8	49.5	0.77	0.0003	4	
63M4B	0.18	1/4	1320	0.58	1.30	3.0	-	1.9	-	2.0	57.0	56.5	56.1	0.76	0.0004	4.5	
63M4C	0.25	1/3	1335	0.85	1.73	3.0	-	2.6	-	2.7	61.5	61.2	61.0	0.68	0.0004	5	
71M4A	0.25	1/3	1325	0.79	1.80	3.2	-	1.7	-	1.7	61.5	61.0	60.8	0.78	0.0006	5	
71M4B	0.37	1/2	1375	1.12	2.50	3.7	-	2.0	-	2.0	66.0	65.8	65.0	0.76	0.0008	6.1	
71M4C	0.55	3/4	1345	1.50	3.30	3.2	-	2.2	-	2.3	70.0	69.5	69.0	0.74	0.0008	6.2	
80M4A	0.55	3/4	1345	1,65	3,80	3,5	-	2,3	-	2,4	70,0	69,7	69,5	0,75	0,0015	8	

Synchronous Speed 1000 rpm

Δ 230 / Y 400

TYPE AA	Rated Power		Nom. Speed rpm	Rated Current 400 V A	Nominal Moment Nm	Starting values				Overturning Moment Nom - Mom M _K /M _{NK}	Efficiency			Power Factor Cosφ	Moment of Inertia kgm ²	Footed Motor Weight kg	
	kW	HP				Current		Moment			η	100%	75%				50%
						I _A /I _N λ	I _A /I _N Δ	M _A /M _N λ	M _A /M _N Δ								
71M6A	0.18	1/4	835	0.75	2.0	2.3	-	2.0	-	2.0	45.5	45.0	44.8	0.69	0.0006	5.5	
71M6B	0.25	1/3	860	0.80	2.7	3.0	-	2.0	-	2.0	52.1	51.7	51.4	0.72	0.0009	6.3	
80M6A	0.37	1/2	905	1,20	3,9	3,3	-	1,9	-	2,0	59,7	59,3	59,0	0,73	0,0015	7,8	
80M6B	0.55	3/4	910	1,55	5,8	3,2	-	2,0	-	2,1	65,8	65,3	65,0	0,74	0,0018	9	

IE2

3 PHASE, VOLTAGE : 400 V.
 FREQUENCY : 50 Hz.
 PROTECTION CLASS : IP 55
 INSULATION CLASS : F
 MODE OF OPERATION : S1

Synchronous Speed 3000 rpm

Δ 230 / Y 400

TYPE AAP	Rated Power		Nom. Speed rpm	Rated Current 400 V A	Nominal Moment Nm	Starting values				Overturning Moment Nom - Mom M _K /M _N	Efficiency			Power Factor Cosφ	Moment of Inertia kgm ²	Footed Motor Weight kg
	kW	HP				Current		Moment			100%	η 75%	50%			
						I _A /I _N λ	I _A /I _N Δ	M _A /M _N λ	M _A /M _N Δ							
80M2A	0,75	1,0	2825	1,70	2,50	6,0	-	2,4	-	2,3	77,4	77,4	75,5	0,84	0,0011	8,5
80M2B	1,1	1,5	2850	2,40	3,65	6,3	-	2,8	-	3,2	79,6	79,6	79,1	0,82	0,0011	13
90S2A	1,5	2,0	2880	3,70	4,99	6,7	-	4,4	-	4,6	81,3	79,4	74,7	0,75	0,0020	16
90L2A	2,2	3,0	2860	4,70	7,40	6,4	-	2,8	-	3,3	83,2	83,2	81,0	0,82	0,0020	16
100L2A	3,0	4,0	2850	6,30	10,0	5,0	-	2,4	-	2,6	84,6	83,4	82,9	0,86	0,0046	22
100L2B	4,0	5,5	2865	8,40	13,0	6,0	-	3,0	-	3,1	85,8	85,1	84,2	0,83	0,0050	23,5

Synchronous Speed 3000 rpm

Δ 400 / Y 690

TYPE AAP/ABP	Rated Power		Nom. Speed rpm	Rated Current 400 V A	Nominal Moment Nm	Starting values				Overturning Moment Nom - Mom M _K /M _N	Efficiency			Power Factor Cosφ	Moment of Inertia kgm ²	Footed Motor Weight kg
	kW	HP				Current		Moment			100%	η 75%	50%			
						I _A /I _N λ	I _A /I _N Δ	M _A /M _N λ	M _A /M _N Δ							
112M2A	4	5,5	2880	8,20	13,0	-	7,6	-	2,4	2,8	85,8	84,9	83,9	0,85	0,0059	25
112M2B	5,5	7,5	2885	10,5	18,0	-	7,5	-	2,4	3,1	87,0	87,0	86,1	0,88	0,0070	30
132S2A	5,5	7,5	2930	10,7	18,0	-	7,0	-	2,2	2,8	87,0	84,0	81,0	0,87	0,0190	43
132S2B	7,5	10,0	2915	13,9	24,3	-	7,7	-	2,5	3,0	88,1	88,1	87,9	0,88	0,0220	49
132M2A	9	12,2	2925	17,9	29,4	-	8,5	-	2,9	3,9	88,8	87,1	84,8	0,83	0,0220	53
132M2B	11	15	2940	20,0	35,7	-	8,1	-	2,3	3,3	89,4	89,3	88,7	0,88	0,0250	60
132M2C	13	18	2925	23,8	42,4	-	8,0	-	2,2	3,2	89,9	89,9	89,1	0,87	0,0400	61
160M2A	11	15	2950	20,2	35,7	-	8,0	-	2,4	3,3	89,4	89,4	89,1	0,87	0,0450	65,5
160M2B	15	20	2945	27,0	48,6	-	6,1	-	1,9	2,4	90,3	90,3	89,9	0,89	0,0500	85
160L2A	18,5	25	2950	33,0	60,0	-	7,6	-	2,5	2,9	90,9	90,5	89,9	0,88	0,0500	103
160L2B	22	30	2960	40,1	72,0	-	11,5	-	3,9	4,8	91,3	91,3	90,9	0,86	0,0840	115
160L2D	30	40	2955	60,0	91,2	-	10,5	-	3,2	3,9	92,0	91,1	89,9	0,83	0,1580	115
180M2A	22	30	2950	38,9	71,2	-	7,0	-	2,4	3,1	91,3	91,0	90,4	0,89	0,1600	122
200L2A	30	40	2955	54,2	97,0	-	8,0	-	2,7	3,7	92,0	86,3	83,6	0,91	0,1600	235
200L2B	37	50	2950	64,1	119,7	-	6,9	-	2,3	2,7	92,5	90,6	89,3	0,92	0,2300	245
200L2C	45	60	2960	78,0	145,0	-	7,2	-	2,2	2,5	92,9	92,3	91,3	0,91	0,3500	270
225M2A	45	60	2960	79,5	145	-	6,9	-	2,3	2,7	92,9	91,5	89,6	0,89	0,4500	341
250M2A	55	75	2965	94,8	177	-	6,9	-	2,4	2,5	93,2	92,8	92,1	0,90	0,5300	395
280S2A	75	100	2960	129,0	242	-	5,7	-	2,0	2,3	93,8	92,9	92,3	0,90	0,6500	518
280M2A	90	120	2970	151,0	290	-	6,5	-	2,0	2,3	94,1	94,1	94,0	0,91	0,7300	518
315S2A	110	150	2970	188,0	353	-	5,5	-	2,0	2,4	94,3	93,4	92,8	0,89	1,2000	882
315M2A	132	175	2975	225,5	423	-	6,0	-	1,8	2,3	94,6	94,0	92,2	0,89	1,4000	900
315M2B	160	210	2975	278,0	511	-	6,4	-	1,8	2,2	94,8	94,2	93,3	0,86	1,5000	905
315L2A	185	250	2970	313,3	595	-	5,5	-	2,3	2,6	95,0	94,9	92,1	0,89	1,8000	930
315L2B	200	270	2960	337,5	645	-	5,5	-	2,2	2,3	95,0	94,4	93,9	0,89	1,8000	1015
355M2A	250	340	2980	422	802	-	8,1	-	2,0	2,2	95,0	95,0	93,3	0,90	3,3	1170
355M2B	315	430	2980	531	1010	-	8,1	-	2,0	2,3	95,0	95,1	93,5	0,90	4,1	1300
355M2C	355	483	2980	605	1135	-	8,2	-	2,0	2,3	95,0	95,0	93,5	0,88	4,5	1365
355L2A	400	544	2980	673	1280	-	7,5	-	1,9	2,5	95,0	95,0	93,5	0,89	4,7	1515
355L2B	450	612	2980	750	1445	-	7,5	-	2,0	2,5	95,0	95,0	93,6	0,91	5,3	1635

IE2

3 PHASE, : 400 V.
 VOLTAGE : 50 Hz.
 FREQUENCY : IP 55
 PROTECTION CLASS : F
 INSULATION CLASS : F
 MODE OF OPERATION : S1

Synchronous Speed 1500 rpm

Δ 230 / Y 400

TYPE AAP	Rated Power		Nom. Speed rpm	Rated Current 400 V A	Nominal Moment Nm	Starting values				Overturning Moment Nom - Mom M_r/M_N	Efficiency η			Power Factor $\cos\phi$	Moment of Inertia kgm^2	Footed Motor Weight kg
	kW	HP				Current		Moment			100%	75%	50%			
						I_A/I_N λ	I_A/I_N Δ	M_A/M_N λ	M_A/M_N Δ							
80M4B	0,75	1	1415	2,0	5,0	5,0	-	2,5	-	3,2	79,6	78,1	73,8	0,69	0,0018	10,3
80M4C	1,1	1,5	1425	2,9	7,4	5,7	-	3,5	-	3,6	81,4	81,4	80,0	0,68	0,0018	14
90S4A	1,1	1,5	1420	2,7	7,4	5,5	-	2,9	-	3,6	81,4	79,4	76,8	0,75	0,0035	14,4
90L4A	1,5	2	1425	3,6	10,0	5,5	-	2,4	-	3,0	82,8	81,4	78,7	0,76	0,0048	16,7
90L4B	2,2	3	1430	5,2	14,7	5,5	-	2,6	-	3,0	84,3	83,9	81,3	0,74	0,0035	19
100L4A	2,2	3	1435	5,0	14,7	5,5	-	2,1	-	2,8	84,3	84,3	83,8	0,77	0,0058	21,6
100L4B	3	4	1435	7,05	20,1	6,2	-	2,7	-	3,0	85,5	85,5	83,5	0,74	0,0063	23,7

Synchronous Speed 1500 rpm

Δ 400 / Y 690

TYPE AAP/ABP	Rated Power		Nom. Speed rpm	Rated Current 400 V A	Nominal Moment Nm	Starting values				Overturning Moment Nom - Mom M_r/M_N	Efficiency η			Power Factor $\cos\phi$	Moment of Inertia kgm^2	Footed Motor Weight kg
	kW	HP				Current		Moment			100%	75%	50%			
						I_A/I_N λ	I_A/I_N Δ	M_A/M_N λ	M_A/M_N Δ							
112M4A	4	5,5	1430	8,2	26,5	-	7,0	-	2,9	3,3	86,6	86,2	85,7	0,83	0,0180	30,6
112M4B	5,5	7,5	1440	11,9	36,5	-	5,9	-	2,5	2,8	87,7	86,2	84,4	0,78	0,0180	37
132S4A	5,5	7,5	1445	11,4	36,0	-	6,3	-	2,3	2,9	87,7	87,7	86,7	0,80	0,0280	47
132M4A	7,5	10	1445	15,8	49,5	-	6,6	-	2,6	3,3	88,7	87,9	86,6	0,78	0,0300	48,5
132M4B	9	12	1455	19,8	59,0	-	6,1	-	2,3	3,1	89,2	88	85,9	0,74	0,0430	48,5
132M4C	11	15	1445	23,5	72,0	-	5,9	-	2,1	2,8	89,8	88,9	87,6	0,77	0,0450	48,5
160M4A	11	15	1460	22,0	71,5	-	5,9	-	2,3	2,7	89,8	90,6	90,1	0,80	0,0500	84
160L4A	15	20	1455	30,5	98,0	-	5,8	-	2,3	2,7	90,6	90,5	90	0,80	0,0700	115
160L4B	18,5	25	1455	36,1	121,0	-	6,5	-	2,3	2,8	91,2	90,7	90,1	0,82	0,1650	120
160L4C	20	27	1460	41,1	130,0	-	6,7	-	2,5	3,1	91,4	91,2	90,2	0,77	0,1750	123
180M4A	18,5	25	1480	35,5	120,2	-	7,2	-	2,7	3,2	91,2	89,8	87,9	0,82	0,1700	148
180L4A	22	30	1470	43,5	143,0	-	6,3	-	2,5	2,7	91,6	91,6	91,1	0,80	0,1830	152
200L4A	30	40	1460	53,5	195,0	-	7,4	-	3,1	3,2	92,3	92,3	91,8	0,88	0,2400	248
200L4B	37	50	1465	65,7	241,0	-	7,2	-	2,3	3,1	92,7	92,7	91,9	0,87	0,4200	270
225S4A	37	50	1465	66,5	240,0	-	5,5	-	1,8	2,1	92,7	92,7	91,8	0,87	0,4400	347
225M4A	45	60	1455	81,0	295,0	-	6,5	-	3,0	3,0	93,1	91,4	91,1	0,89	0,5100	350
225M4B	55	75	1475	99,7	355	-	7,5	-	2,5	3,0	93,5	93,2	92,3	0,85	0,7900	370
250M4A	55	75	1475	96,1	356	-	7,0	-	2,6	2,9	93,5	93,5	92,8	0,88	0,7950	430
280S4A	75	100	1475	133,0	484	-	6,8	-	2,2	2,8	94,0	93,9	93,8	0,88	0,9000	522
280M4A	90	120	1475	157,0	582	-	7,1	-	2,6	2,9	94,2	94,2	94,1	0,89	1,0300	616
280M4B	110	150	1480	193,7	708	-	7,3	-	2,4	2,8	94,5	94,5	94,0	0,87	1,2500	677
315S4A	110	150	1485	199,0	707	-	6,5	-	2,0	3,0	94,5	94,3	93,4	0,85	1,3000	835
315M4A	132	175	1480	225,5	850	-	6,6	-	2,1	2,7	94,7	94,7	94,2	0,89	1,5000	940
315M4B	160	210	1485	285,0	1028	-	8,0	-	2,1	3,1	94,9	94,8	94,2	0,85	1,6000	947
315L4A	185	250	1485	315,3	1193	-	5,2	-	2,3	3,2	95,1	94,8	94,0	0,89	1,8300	1150
315L4B	200	270	1485	365,0	1285	-	5,2	-	2,0	3,1	95,1	94,5	93,7	0,83	1,9000	1170
315L4D	250	340	1485	436	1608	-	7,5	-	2,1	3,2	95,1	95,1	94,7	0,87	5,4000	1255
355M4A	250	340	1485	450	1610	-	6,5	-	2,1	2,8	95,1	95,0	94,3	0,85	5,5	1380
355M4B	315	430	1485	562	2020	-	7,0	-	2,1	2,8	95,1	95,0	94,1	0,85	6,0	1420
355M4C	355	483	1485	633	2275	-	7,0	-	2,5	2,8	95,1	95,0	94,3	0,85	6,5	1440
355L4A	400	544	1485	710	2570	-	7,1	-	2,5	2,6	95,1	95,0	94,5	0,85	7,2	1470
355L4B	450	612	1485	805	2885	-	7,1	-	2,6	2,6	95,1	95,0	94,5	0,85	8,2	1635

IE2

3 PHASE,
 VOLTAGE : 400 V.
 FREQUENCY : 50 Hz.
 PROTECTION CLASS : IP 55
 INSULATION CLASS : F
 MODE OF OPERATION : S1

Synchronous Speed 1000 rpm

Δ 230 / Y 400

TYPE AAP	Rated Power		Nom. Speed rpm	Rated Current 400 V A	Nominal Moment Nm	Starting values				Overturning Moment Nom - Mom M _R /M _N	Efficiency			Power Factor Cosφ	Moment of Inertia kgm ²	Footed Motor Weight kg
	kW	HP				Current I _A /I _N λ	I _A /I _N Δ	Moment M _A /M _N λ	Moment M _A /M _N Δ		100%	η 75%	50%			
90S6A	0,75	1	935	2,15	7,62	4,5	-	2,1	-	2,7	75,9	75,9	73,5	0,68	0,0036	15,5
90L6A	1,1	1,5	935	3,00	11,2	4,5	-	2,0	-	2,7	78,1	77,8	74,7	0,70	0,0040	16,5
100L6A	1,5	2	945	3,90	15,0	6,6	-	3,5	-	3,0	79,8	78,8	75,0	0,71	0,0090	22
112M6A	2,2	3	950	5,60	22,1	5,0	-	2,0	-	2,7	81,8	81,1	79,8	0,69	0,0130	26

Synchronous Speed 1000 rpm

Δ 400 / Y 690

TYPE AAP/ABP	Rated Power		Nom. Speed rpm	Rated Current 400 V A	Nominal Moment Nm	Starting values				Overturning Moment Nom - Mom M _R /M _N	Efficiency			Power Factor Cosφ	Moment of Inertia kgm ²	Footed Motor Weight kg
	kW	HP				Current I _A /I _N λ	I _A /I _N Δ	Moment M _A /M _N λ	Moment M _A /M _N Δ		100%	η 75%	50%			
132S6A	3	4	960	7,2	29,8	-	4,9	-	1,9	2,5	83,3	83,3	83,2	0,72	0,0028	39
132M6A	4	5,5	955	9,1	39,6	-	4,3	-	2,0	2,5	84,6	84,6	84,1	0,77	0,0035	46,5
132M6B	5,5	7,5	955	12,3	55,0	-	4,8	-	1,8	2,3	86,0	86,0	85,3	0,75	0,0040	52
160M6A	7,5	10	965	16,1	74,0	-	6,0	-	2,2	3,3	87,2	87,2	86,8	0,76	0,0080	90
160L6A	11	15	965	23,2	108,8	-	6,0	-	2,2	3,0	88,7	88,7	88,1	0,78	0,1000	102
180L6A	15	20	965	30,6	147,0	-	4,4	-	2,5	2,7	89,7	89,1	88,8	0,85	0,2200	145
200L6A	18,5	25	970	35,5	181,0	-	6,5	-	2,5	2,9	90,4	90,4	90,1	0,83	0,2400	240
200L6B	22	30	970	41,6	215,8	-	7,1	-	3,3	5,4	90,9	90,9	89,8	0,83	0,3000	248
225M6A	30	40	980	57,6	292,0	-	5,1	-	1,6	2,1	91,7	91,7	91,3	0,82	0,6400	390
250M6A	37	50	980	71,0	360,5	-	5,5	-	1,8	2,0	92,2	92,2	91,8	0,83	0,9500	470
280S6A	45	60	985	90,5	436,0	-	6,9	-	2,5	2,9	92,7	92,7	91,8	0,77	1,5000	488
280M6A	55	75	985	113,5	532,0	-	7,0	-	2,1	2,0	93,1	92,6	91,8	0,76	1,7500	580
315S6A	75	100	990	139,5	724,0	-	5,0	-	1,8	2,3	93,7	93,5	92,5	0,83	2,0000	840
315M6A	90	120	990	171,5	867	-	5,6	-	1,9	2,4	94,0	93,8	93,1	0,81	2,3000	855
315M6B	110	150	990	202,0	1060	-	5,4	-	2,1	2,9	94,3	92,1	91,3	0,81	2,4000	892
315L6A	132	175	980	236,8	1285	-	5,0	-	1,85	2,5	94,6	93,5	92,1	0,85	2,5500	902
315L6B	160	210	985	285,2	1545	-	5,0	-	1,9	2,5	94,8	93,5	92,1	0,85	2,7500	1010
355M6A	160	220	990	310	1540	-	7,1	-	2,5	2,3	94,8	94,5	93,1	0,78	5,0000	1050
355M6B	200	272	990	385	1930	-	7,1	-	2,5	2,4	95,0	94,5	93,2	0,80	6,8000	1190
355M6C	250	340	985	475	2415	-	7,1	-	2,5	2,4	95,0	95,0	93,2	0,80	8,3000	1395
355L6A	315	428	985	585	3040	-	7,1	-	2,5	2,4	95,0	95,0	93,0	0,83	10,700	1755
355L6B	355	483	985	655	3425	-	7,1	-	2,5	2,4	95,0	95,0	93,0	0,82	11,7	1895

IE2

3 PHASE,
VOLTAGE : 460 V.
FREQUENCY : 60 Hz.
PROTECTION CLASS : IP 55
INSULATION CLASS : F
MODE OF OPERATION : S1

Synchronous Speed 3600 rpm

Δ 264/ Y 460

TYPE AAP	Rated Power		Nom. Speed rpm	Rated Current 460 V A	Nominal Moment Nm	Starting values				Overturning Moment Nom - Mom M_K/M_N	Efficiency			Power Factor $\cos\phi$	Moment of Inertia kgm^2	Footed Motor Weight kg
	kW	HP				Current I_A/I_N λ	I_Δ/I_N Δ	Moment M_A/M_N λ	Δ		100%	η 75%	50%			
80M2A	0,86	1,15	3390	1,70	2,40	6,0	-	2,2	-	2,1	75,5	74,9	73,2	0,84	0,00110	8,5
80M2B	1,27	1,70	3420	2,40	3,51	6,3	-	2,6	-	3,0	82,5	81,6	81,3	0,82	0,00110	13
90S2A	1,73	2,32	3455	3,70	4,80	6,7	-	4,1	-	4,3	84,0	82,3	80,9	0,75	0,00200	16
90L2A	2,53	3,39	3430	4,70	7,12	6,4	-	2,6	-	3,1	85,5	84,7	83,4	0,82	0,00200	16
100L2A	3,45	4,62	3420	6,30	9,62	5,0	-	2,2	-	2,4	87,5	86,2	84,6	0,86	0,00460	22
100L2B	4,60	6,17	3440	8,40	12,50	6,0	-	2,8	-	2,9	88,5	86,2	85,5	0,83	0,00500	23,5

Synchronous Speed 3600 rpm

Δ 460 / Y 796

TYPE AAP/ABP	Rated Power		Nom. Speed rpm	Rated Current 460 V A	Nominal Moment Nm	Starting values				Overturning Moment Nom - Mom M_K/M_N	Efficiency			Power Factor $\cos\phi$	Moment of Inertia kgm^2	Footed Motor Weight kg
	kW	HP				Current I_A/I_N λ	I_Δ/I_N Δ	Moment M_A/M_N λ	Δ		100%	η 75%	50%			
112M2A	4,60	6,17	3455	8,20	12,5	-	7,6	-	2,2	2,6	88,5	87,6	86,1	0,85	0,0059	25
112M2B	6,33	8,49	3460	10,5	17,3	-	7,5	-	2,2	2,9	88,5	85,3	82,8	0,88	0,0070	30
132S2A	6,33	8,49	3515	10,7	17,3	-	7,0	-	2,0	2,6	88,5	87,5	86,2	0,87	0,0190	43
132S2B	8,60	11,5	3500	13,9	23,4	-	7,7	-	2,3	2,8	89,5	88,3	87,6	0,88	0,0220	49
132M2A	10,4	14,0	3515	17,9	28,3	-	8,5	-	2,7	3,6	90,2	89,1	87,6	0,83	0,0220	53
132M2B	12,7	17,0	3530	20,0	34,3	-	8,1	-	2,1	3,1	90,2	88,3	87,6	0,88	0,0250	60
132M2C	15,0	20,7	3510	23,8	40,8	-	8,0	-	2,0	3,0	90,2	89,5	88,1	0,87	0,0400	61
160M2A	12,7	17,0	3540	20,2	34,3	-	8,0	-	2,2	3,1	90,2	89,1	88,4	0,87	0,0450	65,5
160M2B	17,3	23,0	3535	27,0	46,7	-	6,1	-	1,8	2,2	91,0	90,3	88,6	0,89	0,0500	85
160L2A	21,3	28,5	3540	33,0	57,7	-	7,6	-	2,3	2,7	91,0	90,2	89,9	0,88	0,0500	103
160L2B	25,3	34,4	3550	40,1	69,2	-	11,5	-	3,6	4,4	91,0	89,2	88,6	0,86	0,0840	115
160L2D	34,5	47,0	3545	60,0	87,7	-	10,5	-	3,0	3,6	92,4	91,3	89,9	0,83	0,1580	115
180M2A	25,3	34,4	3540	38,9	68,5	-	7,0	-	2,2	2,9	91,0	90,6	90,8	0,89	0,1600	122
200L2A	34,5	47,0	3545	54,2	93,3	-	8,0	-	2,5	3,4	92,4	91,3	90,9	0,91	0,1600	235
200L2B	42,5	58,0	3540	64,1	115,1	-	6,9	-	2,1	2,5	93,0	92,4	90,8	0,92	0,2300	245
200L2C	51,7	70,0	3550	78,0	139,4	-	7,2	-	2,0	2,3	93,0	92,6	91,3	0,91	0,3500	270
225M2A	51,7	70,0	3550	79,5	139,4	-	6,9	-	2,1	2,5	93,0	92,2	91,9	0,89	0,4500	341
250M2A	63,2	86,0	3560	94,8	170,2	-	6,9	-	2,2	2,3	93,0	92,5	90,3	0,90	0,5300	395
280S2A	86,2	117,0	3550	129,0	232,7	-	5,7	-	1,9	2,1	94,5	94,0	93,6	0,90	0,6500	518
280M2A	103,0	138,0	3565	151,0	278,8	-	6,5	-	1,9	2,1	94,5	93,8	92,4	0,91	0,7300	518
315S2A	126,0	169,0	3565	188,0	339,4	-	5,5	-	1,9	2,2	94,5	93,8	92,7	0,89	1,2000	882
315M2A	152,0	206,0	3570	225,5	406,7	-	6,0	-	1,7	2,1	95,0	94,2	93,5	0,89	1,4000	900
315M2B	184,0	250,0	3570	278,0	491,3	-	6,4	-	1,7	2,0	95,4	94,5	92,8	0,86	1,5000	905
315L2A	212,0	289,0	3565	3	572,1	-	5,5	-	2,1	2,4	95,4	93,3	92,2	0,89	1,8000	930
315L2B	230,0	313,0	3550	337,5	620,2	-	5,5	-	2,0	2,1	95,4	94,2	93,9	0,89	1,8000	1015
355M2A	287,5	462,0	3575	422	771,2	-	8,1	-	1,9	2,0	95,4	95,0	93,3	0,90	3,3	1170
355M2B	362,3	585,0	3575	531	971,2	-	8,1	-	1,9	2,1	95,4	95,1	93,5	0,90	4,1	1300
355M2C	408,2	657,0	3575	605	1091	-	3,2	-	1,0	2,1	95,4	95,0	93,5	0,88	4,5	1365
355L2A	460,0	740,0	3575	673	1231	-	7,5	-	1,8	2,3	95,4	95,0	93,5	0,89	4,7	1515
355L2B	517,5	832,0	3575	750	1389	-	7,5	-	1,9	2,3	95,4	95,0	93,6	0,91	5,3	1635

IE2

3 PHASE, VOLTAGE : 460 V.
 FREQUENCY : 60 Hz.
 PROTECTION CLASS : IP 55
 INSULATION CLASS : F
 MODE OF OPERATION : S1

Synchronous Speed 1800 rpm											Δ 264 / Y 460					
TYPE AAP	Rated Power		Nom. Speed rpm	Rated Current 460 V A	Nominal Moment Nm	Starting values				Overturning Moment Nom - Mom M_K/M_N	Efficiency			Power Factor Cosφ	Moment of Inertia kgm^2	Footed Motor Weight kg
	kW	HP				Current I_A/I_N	I_A/I_N	Moment M_A/M_N			100%	η	50%			
						λ	Δ	λ	Δ							
80M4B	0,86	1,15	1700	2,00	4,8	5,0	-	2,3	-	3,0	78,0	77,2	77,6	0,69	0,0018	10,3
80M4C	1,27	1,70	1710	2,90	7,1	5,7	-	3,2	-	3,3	84,0	83,5	83,9	0,68	0,0018	14
90S4A	1,27	1,70	1705	2,70	7,1	5,5	-	2,7	-	3,3	84,0	83,2	82,7	0,75	0,0035	14,4
90L4A	1,73	2,32	1710	3,60	9,6	5,5	-	2,2	-	2,8	84,0	82,9	81,6	0,76	0,0048	16,7
90L4B	2,53	3,39	1715	5,20	14,1	5,5	-	2,4	-	2,8	87,5	86,4	84,2	0,74	0,0035	19
100L4A	2,53	3,39	1720	5,00	14,1	5,5	-	1,9	-	2,6	87,5	86,9	85,3	0,77	0,0058	21,6
100L4B	3,45	4,62	1720	7,05	19,3	6,2	-	2,5	-	2,8	87,5	86,2	85,3	0,74	0,0063	23,7

Synchronous Speed 1800 rpm											Δ 460 / Y 796					
TYPE AAP/ABP	Rated Power		Nom. Speed rpm	Rated Current 460 V A	Nominal Moment Nm	Starting values				Overturning Moment Nom - Mom M_K/M_N	Efficiency			Power Factor Cosφ	Moment of Inertia kgm^2	Footed Motor Weight kg
	kW	HP				Current I_A/I_N	I_A/I_N	Moment M_A/M_N			100%	η	50%			
						λ	Δ	λ	Δ							
112M4A	4,60	6,17	1715	8,20	25	-	7,0	-	2,7	3,1	89,5	88,2	87,6	0,83	0,0180	30,6
112M4B	6,33	8,49	1730	11,9	35	-	5,9	-	2,3	2,6	89,5	86,4	85,2	0,78	0,0180	37
132S4A	6,33	8,49	1735	11,4	35	-	6,3	-	2,1	2,7	89,5	88,3	87,6	0,80	0,0280	47
132M4A	8,60	11,5	1735	15,8	48	-	6,6	-	2,4	3,1	89,5	88,7	86,4	0,78	0,0300	48,5
132M4B	10,4	13,9	1745	19,8	57	-	6,1	-	2,1	2,9	91,0	89,2	88,7	0,74	0,0430	48,5
132M4C	12,7	17,0	1735	23,5	69	-	5,9	-	1,9	2,6	91,0	90,8	89,2	0,77	0,0450	48,5
160M4A	12,7	17,0	1755	22,0	69	-	5,9	-	2,1	2,5	91,0	90,7	89,4	0,80	0,0500	84
160L4A	17,3	23,0	1745	30,5	94	-	5,8	-	2,1	2,5	92,4	91,8	90,7	0,80	0,0700	115
160L4B	21,3	30,0	1745	36,1	116	-	6,5	-	2,1	2,6	92,4	91,2	91,0	0,82	0,1650	120
160L4C	23,0	31,1	1750	41,1	125	-	6,7	-	2,3	2,9	92,4	91,6	91,2	0,77	0,1750	123
180M4A	21,3	30,0	1775	35,5	116	-	7,2	-	2,5	3,0	92,4	91,8	90,7	0,82	0,1700	148
180L4A	25,3	34,5	1765	43,5	138	-	6,3	-	2,3	2,5	92,4	91,6	90,8	0,80	0,1830	152
200L4A	34,5	47,0	1750	53,5	188	-	7,4	-	2,9	3,0	93,0	92,6	91,8	0,88	0,2400	248
200L4B	42,5	58,0	1760	65,7	232	-	7,2	-	2,1	2,9	93,6	92,8	91,6	0,87	0,4200	270
225S4A	42,5	58,0	1760	66,5	231	-	5,5	-	1,7	1,9	93,6	92,8	91,6	0,87	0,4400	347
225M4A	51,7	70,0	1745	81,0	284	-	6,5	-	2,8	2,8	94,1	93,7	92,3	0,89	0,5100	350
225M4B	63,2	86,0	1770	99,7	341	-	7,5	-	2,3	2,8	94,1	93,5	92,6	0,85	0,7900	370
250M4A	63,2	86,0	1770	96,1	342	-	7,0	-	2,4	2,7	94,1	93,8	92,6	0,88	0,7950	430
280S4A	86,2	115,0	1770	133,0	465	-	6,8	-	2,0	2,6	94,5	92,6	91,7	0,88	0,9000	522
280M4A	103,0	138,0	1770	157,0	560	-	7,1	-	2,4	2,7	95,0	94,2	93,7	0,89	1,0300	616
280M4B	126,0	169,0	1775	193,7	681	-	7,3	-	2,2	2,6	95,0	93,5	92,8	0,87	1,2500	677
315S4A	126,0	169,0	1780	199,0	680	-	6,5	-	1,9	2,8	95,0	94,2	93,6	0,85	1,3000	835
315M4A	152,0	206,0	1775	225,5	817	-	6,6	-	1,9	2,5	95,0	94,1	93,2	0,89	1,5000	940
315M4B	184,0	250,0	1780	285,0	988	-	8,0	-	1,9	2,9	95,0	94,6	94,8	0,85	1,6000	947
315L4A	212,0	289,0	1780	315,3	1147	-	5,2	-	2,1	3,0	95,4	94,8	94,0	0,89	1,8300	1150
315L4B	230,0	313,0	1780	365,0	1236	-	5,2	-	1,9	2,9	95,4	94,3	93,6	0,83	1,9000	1170
315L4D	287,5	462,0	1780	436	1546	-	7,1	-	1,9	2,6	95,0	95,0	95,8	0,85	5,4000	1255
355M4A	287,5	462,0	1780	450	1548	-	6,5	-	1,9	2,6	95,0	95,0	94,3	0,85	5,5000	1380
355M4B	362,3	585,0	1780	562	1942	-	7,0	-	1,9	2,6	95,0	95,0	94,1	0,85	6,0000	1420
355M4C	408,2	657,0	1780	633	2188	-	7,0	-	2,3	2,6	95,0	95,0	94,3	0,85	6,5000	1440
355L4A	460,0	740,0	1780	710	2471	-	7,1	-	2,3	2,4	95,0	95,0	94,5	0,85	7,2000	1470
355L4B	517,5	832,0	1780	805	2774	-	7,1	-	2,4	2,4	95,0	95,0	94,5	0,85	8,2000	1635

Performance Values

IE2

3 PHASE,
 VOLTAGE : 460 V.
 FREQUENCY : 60 Hz.
 PROTECTION CLASS : IP 55
 INSULATION CLASS : F
 MODE OF OPERATION : S1

Synchronous Speed 1200 rpm

Δ 264 / Y 460

TYPE AAP	Rated Power		Nom. Speed rpm	Rated Current 460 V A	Nominal Moment Nm	Starting values				Overturning Moment Nom - Mom M _K /M _N	Efficiency			Power Factor Cosφ	Moment of Inertia kgm ²	Footed Motor Weight kg
	kW	HP				Current		Moment			100%	η 75%	50%			
						I _A /I _N λ	I _Δ /I _N Δ	M _λ /M _N λ	M _Δ /M _N Δ							
90S6A	0,86	1,15	1120	2,15	7,33	4,5	-	1,9	-	2,5	73,0	72,4	71,6	0,68	0,0036	15,5
90L6A	1,27	1,70	1120	3,00	10,77	4,5	-	1,9	-	2,5	85,5	84,2	83,8	0,70	0,0040	16,5
100L6A	1,73	2,32	1135	3,90	14,42	6,6	-	3,2	-	2,8	86,5	85,4	84,2	0,71	0,0090	22
112M6A	2,53	3,39	1140	5,60	21,25	5,0	-	1,9	-	2,5	87,5	86,2	85,6	0,69	0,0130	26

Synchronous Speed 1200 rpm

Δ 460 / Y 796

TYPE AAP/ABP	Rated Power		Nom. Speed rpm	Rated Current 460 V A	Nominal Moment Nm	Starting values				Overturning Moment Nom - Mom M _K /M _N	Efficiency			Power Factor Cosφ	Moment of Inertia kgm ²	Footed Motor Weight kg
	kW	HP				Current		Moment			100%	η 75%	50%			
						I _A /I _N λ	I _Δ /I _N Δ	M _λ /M _N λ	M _Δ /M _N Δ							
132S6A	3,45	4,62	1155	7,2	28,7	-	4,9	-	1,8	2,3	87,5	86,2	85,4	0,72	0,0028	39
132M6A	4,60	6,17	1145	9,1	38,1	-	4,3	-	1,9	2,3	89,5	88,4	87,7	0,77	0,0035	46,5
132M6B	6,33	8,49	1145	12,3	52,9	-	4,8	-	1,7	2,1	89,5	88,8	87,1	0,75	0,0040	52
160M6A	8,60	11,5	1160	16,1	71,2	-	6,0	-	2,0	3,1	89,5	89,1	88,3	0,76	0,0080	90
160L6A	12,7	17,0	1160	23,2	104,6	-	6,0	-	2,0	2,8	90,2	89,9	88,4	0,78	0,1000	102
180L6A	17,2	23,0	1160	30,6	141,3	-	4,4	-	2,3	2,5	91,7	90,6	90,0	0,85	0,2200	145
200L6A	21,3	29,0	1165	35,5	174,0	-	6,5	-	2,3	2,7	91,7	91,0	89,2	0,83	0,2400	240
200L6B	25,3	34,5	1165	41,6	207,5	-	7,1	-	3,1	5,0	91,7	92,2	90,8	0,83	0,3000	248
225M6A	34,5	47,0	1175	57,6	280,7	-	5,1	-	1,5	1,9	93,0	92,6	91,7	0,82	0,6400	390
250M6A	42,5	58,0	1175	71,0	346,6	-	5,5	-	1,7	1,9	93,6	92,4	91,8	0,83	0,9500	470
280S6A	51,8	70,4	1180	90,5	419,2	-	6,9	-	2,3	2,7	93,6	93,0	92,4	0,77	1,5000	488
280M6A	63,2	86,0	1180	113,5	511,5	-	7,0	-	1,9	1,9	93,6	93,2	91,5	0,76	1,7500	580
315S6A	86,2	117,0	1190	139,5	696,2	-	5,0	-	1,7	2,1	94,1	93,7	92,4	0,83	2,0000	840
315M6A	103,0	138,0	1190	171,5	833,7	-	5,6	-	1,8	2,2	95,0	94,8	93,9	0,81	2,3000	855
315M6B	126,0	169,0	1190	202,0	1019	-	5,4	-	1,9	2,7	95,0	94,6	93,0	0,81	2,4000	892
315L6A	152,0	206,0	1175	236,8	1236	-	5,0	-	1,7	2,3	95,0	94,1	93,7	0,85	2,5500	902
315L6B	184,0	250,0	1180	285,2	1486	-	5,0	-	1,8	2,3	95,0	94,5	93,5	0,85	2,7500	1010
355M6A	184,0	300,0	1190	310	1481	-	7,1	-	2,3	2,1	95,0	94,5	93,1	0,78	5,0000	1050
355M6B	230,0	370,0	1190	385	1856	-	7,1	-	2,3	2,2	95,0	94,5	93,2	0,80	6,8000	1190
355M6C	287,5	462,0	1180	475	2322	-	7,1	-	2,3	2,2	95,0	95,0	93,2	0,80	8,3000	1395
355L6A	362,2	583,0	1180	585	2923	-	7,1	-	2,3	2,2	95,0	95,0	93,0	0,83	10,700	1755
355L6B	402,1	657,0	1180	655	3293	-	7,1	-	2,3	2,2	95,0	95,0	93,0	0,82	11,7	1895

IE3

3 PHASE,
VOLTAGE : 400 V.
FREQUENCY : 50 Hz.
PROTECTION CLASS : IP 55
INSULATION CLASS : F
MODE OF OPERATION : S1

Synchronous Speed 3000 rpm

Δ 230 / Y 400

TYPE AAP	Rated Power		Nom. Speed rpm	Rated Current 400 V A	Nominal Moment Nm	Starting values				Overturning Moment Nom - Mom M _K /M _N	Efficiency			Power Factor Cosφ	Moment of Inertia kgm ²	Footed Motor Weight kg
	kW	HP				Current		Moment			100%	75%	50%			
						I _A /I _N λ	I _Δ /I _N Δ	M _A /M _N λ	M _Δ /M _N Δ							
80M2A	0,75	1	2885	1,60	2,5	7,5	-	3,1	-	3,5	80,7	78,5	64,5	0,83	0,00066	10
80M2B	1,1	1,5	2885	2,50	3,7	5,6	-	2,4	-	3,5	82,7	80,4	77,3	0,79	0,00080	11
90S2A	1,5	2	2880	3,45	5,0	7,2	-	4,4	-	4,6	84,2	84,2	84,1	0,74	0,00140	15,5
90L2A	2,2	3	2875	4,70	7,30	8,1	-	3,65	-	3,7	85,9	83,6	82,1	0,81	0,00170	16,5
100L2A	3	4	2910	6,1	9,80	7,0	-	2,5	-	3,5	87,1	86,7	84,6	0,82	0,00310	23

Synchronous Speed 3000 rpm

Δ 400 / Y 690

TYPE AAP/ABP	Rated Power		Nom. Speed rpm	Rated Current 400 V A	Nominal Moment Nm	Starting values				Overturning Moment Nom - Mom M _K /M _N	Efficiency			Power Factor Cosφ	Moment of Inertia kgm ²	Footed Motor Weight kg
	kW	HP				Current		Moment			100%	75%	50%			
						I _A /I _N λ	I _Δ /I _N Δ	M _A /M _N λ	M _Δ /M _N Δ							
112M2A	4	5,5	2900	7,9	13	-	7,6	-	2,5	3,45	88,1	85,9	84,2	0,86	0,0048	29,5
132S2A	5,5	7,5	2930	10	18	-	7,5	-	3,4	4,6	89,2	88,5	86,9	0,90	0,0130	49
132S2B	7,5	10	2940	13,5	24	-	7,2	-	3,1	4,6	90,1	90,1	88,4	0,90	0,0170	55
160M2A	11	15	2955	19,7	36	-	6,5	-	2,3	2,95	91,2	91,2	90,7	0,88	0,0340	82
160M2B	15	20	2960	26,5	49	-	7,6	-	2,75	3,7	91,9	91,9	90,4	0,89	0,0460	90
160L2A	18,5	25	2955	32,6	60	-	8,2	-	2,8	3,5	92,4	92,4	91,7	0,91	0,0560	97
180M2A	22	30	2955	38,2	71	-	7,0	-	2,40	3,10	92,7	91,8	90,5	0,90	0,0750	180
200L2A	30	40	2965	52,0	96	-	8,5	-	3,4	4,2	93,3	93,3	93,1	0,92	0,1500	250
200L2B	37	50	2960	62,0	119	-	10,1	-	2,86	4,04	93,7	92,9	92,1	0,93	0,1700	265
225M2A	45	60	2955	77,5	145	-	8,70	-	2,80	3,10	94,0	92,1	91,1	0,92	0,2600	374
250M2A	55	75	2970	92,0	176	-	8,70	-	2,90	3,0	94,3	93,5	93,3	0,92	0,4700	460
280S2A	75	100	2980	127,0	240	-	8,0	-	2,90	3,20	94,7	94,3	93,6	0,91	0,6200	500
280M2A	90	120	2980	150,1	290	-	8,2	-	2,90	3,00	95,0	94,8	94,2	0,92	0,7400	575
315S2A	110	150	2980	186,0	355	-	8,0	-	2,50	3,00	95,2	94,6	94,1	0,90	1,2000	850
315M2A	132	175	2980	223,0	425	-	8,0	-	2,40	3,50	95,4	94,4	93,9	0,90	1,4000	870
315M2B	160	210	2980	265,0	511	-	8,0	-	2,50	3,00	95,6	95,0	94,5	0,91	1,5000	920
315L2A	185	250	2985	305,0	595	-	7,5	-	2,50	2,80	95,8	95,1	94,4	0,92	1,8500	1060
315L2B	200	270	2980	325,0	645	-	7,5	-	2,50	2,80	95,8	95,1	94,5	0,93	1,8000	1100
355M2A	250	340	2980	415	802	-	8,1	-	2,0	2,20	95,8	95,2	93,5	0,91	3,3000	1175
355M2B	315	430	2980	428	1010	-	8,1	-	2,0	2,3	95,8	95,2	93,6	0,91	4,1000	1310
355M2C	355	483	2980	602	1135	-	8,2	-	2,0	2,3	95,8	95,1	93,3	0,90	4,5000	1375
355L2A	400	544	2980	670	1280	-	7,5	-	1,9	2,5	95,8	95,1	93,5	0,90	4,7000	1525
355L2B	450	612	2980	745	1445	-	7,5	-	2,0	2,5	95,8	95,1	93,8	0,90	5,3	1645

IE3

3 PHASE,
 VOLTAGE : 400 V.
 FREQUENCY : 50 Hz.
 PROTECTION CLASS : IP55
 INSULATION CLASS : F
 MODE OF OPERATION : S1

Synchronous Speed 1500 rpm

Δ 230 / Y 400 V

TYPE AAP	Rated Power		Nom. Speed rpm	Rated Current 400 V A	Nominal Moment Nm	Starting values				Overturning Moment Nom - Mom M _K /M _N	Efficiency			Power Factor Cosφ	Moment of Inertia kgm ²	Footed Motor Weight kg
	kW	HP				Current		Moment			100%	η 75%	50%			
						I _A /I _N λ	I _Δ /I _N Δ	M _λ /M _N λ	M _Δ /M _N Δ							
80M4B	0,75	1	1435	1,90	5,0	5,7	-	2,5	-	2,75	82,5	81,0	79,4	0,70	0,0014	13,5
90S4A	1,1	1,5	1435	2,55	7,35	6,6	-	3,6	-	3,8	84,1	82,9	80,8	0,75	0,0025	17
90L4A	1,5	2	1450	3,40	9,90	6,5	-	2,7	-	3,8	85,3	84,8	82,3	0,75	0,0033	20
100L4A	2,2	3	1450	4,90	14,5	6,7	-	2,7	-	3,65	86,7	86,7	84,4	0,73	0,0052	26
100L4B	3	4	1450	6,40	19,8	6,9	-	2,5	-	3,5	87,7	87,3	85,4	0,77	0,0068	31

Synchronous Speed 1500 rpm

Δ 400 / Y 690 V

TYPE AAP/ABP	Rated Power		Nom. Speed rpm	Rated Current 400 V A	Nominal Moment Nm	Starting values				Overturning Moment Nom - Mom M _K /M _N	Efficiency			Power Factor Cosφ	Moment of Inertia kgm ²	Footed Motor Weight kg
	kW	HP				Current		Moment			100%	η 75%	50%			
						I _A /I _N λ	I _Δ /I _N Δ	M _λ /M _N λ	M _Δ /M _N Δ							
112M4A	4	5,5	1450	8,2	26,3	-	7,0	-	3,0	3,5	88,6	87,8	86,1	0,80	0,012	35
132S4A	5,5	7,5	1460	11,5	35,8	-	7,9	-	3,3	3,9	89,6	89,3	87,5	0,77	0,026	52
132M4A	7,5	10	1460	15,9	49,1	-	7,4	-	3,0	3,8	90,4	89,1	87,4	0,75	0,032	59
160M4A	11	15	1470	22,9	71,6	-	6,9	-	2,8	3,3	91,4	91,4	90,8	0,76	0,072	101
160L4A	15	20	1470	30,5	97,5	-	7,9	-	3,1	3,6	92,1	90,3	90,1	0,77	0,092	120
180M4A	18,5	25	1475	36,3	120	-	7,9	-	3,1	3,0	92,6	92,5	92,1	0,80	0,170	156
180L4A	22	30	1480	44,5	143	-	8,8	-	3,4	3,2	93,0	92,6	91,7	0,77	0,170	170
200L4A	30	40	1470	52,5	195	-	7,7	-	2,7	3,1	93,6	92,4	92,1	0,88	0,250	270
225S4A	37	50	1470	64,8	240	-	7,5	-	3,1	3,4	93,9	93,6	93,2	0,88	0,360	361
225M4A	45	60	1480	81,0	290	-	8,2	-	2,7	4,1	94,2	93,4	92,5	0,86	0,510	360
250M4A	55	75	1480	96,0	355	-	7,7	-	3,2	3,0	94,6	94,6	94,1	0,89	0,780	450
280S4A	75	100	1485	133,0	483	-	7,6	-	2,9	3,0	95,0	94,9	94,2	0,87	1,110	623
280M4A	90	120	1485	155,2	579	-	7,4	-	2,9	3,0	95,2	94,6	94,1	0,89	1,320	650
315S4A	110	150	1485	192,0	705	-	7,4	-	2,4	3,0	95,4	94,8	93,8	0,87	2,500	875
315M4A	132	175	1487	230,0	850	-	7,4	-	2,3	3,0	95,6	95,1	94,5	0,87	2,800	955
315M4B	160	210	1485	275,0	1025	-	6,9	-	2,2	2,9	95,8	95,6	95,3	0,88	3,000	970
315L4A	185	250	1485	321,0	1193	-	6,9	-	2,2	2,9	96,0	95,5	95,1	0,87	3,100	1010
315L4B	200	270	1485	347,0	1285	-	5,2	-	2,0	3,1	96,0	95,6	95,1	0,87	3,300	1055
355M4A	250	340	1485	436,0	1610	-	6,5	-	2,1	2,8	96,0	95,1	94,5	0,88	5,500	1395
355M4B	315	430	1485	558	2020	-	7,0	-	2,1	2,8	96,0	95,2	94,5	0,88	6,000	1435
355M4C	355	483	1485	630	2275	-	7,0	-	2,5	2,8	96,0	95,1	94,1	0,88	6,500	1455
355L4A	400	544	1485	703	2570	-	7,1	-	2,5	2,6	96,0	95,1	94,6	0,88	7,200	1475
355L4B	450	612	1485	801	2885	-	7,1	-	2,6	2,6	96,0	95,1	94,6	0,88	8,200	1640

IE3

3 PHASE, : 400 V.
 VOLTAGE : 50 Hz.
 FREQUENCY : IP 55
 PROTECTION CLASS : F
 INSULATION CLASS : S1
 MODE OF OPERATION

Synchronous Speed 1000 rpm

Δ 230 / Y 400

TYPE AAP	Rated Power		Nom. Speed rpm	Rated Current 400 V A	Nominal Moment Nm	Starting values				Overturning Moment Nom - Mom M _K /M _N	Efficiency			Power Factor Cosφ	Moment of Inertia kgm ²	Footed Motor Weight kg
	kW	HP				Current		Moment			100%	η				
						I _A /I _N λ	I _A /I _N Δ	M _A /M _N λ	M _A /M _N Δ			75%	50%			
90S6A	0,75	1	940	2,05	7,62	3,9	-	1,97	-	2,40	78,9	77,5	73,6	0,65	0,0038	18
90L6A	1,1	1,5	935	3,05	11,3	4,8	-	2,8	-	3,05	81,0	78,5	74,7	0,69	0,0051	20,5
100L6A	1,5	2	940	3,60	15,3	5,0	-	2,36	-	3,0	82,5	81,5	79,9	0,70	0,0110	26
112M6A	2,2	3	970	5,1	21,2	6,2	-	2,3	-	3,2	84,3	83,5	82,6	0,72	0,0160	28

Synchronous Speed 1000 rpm

Δ 400 / Y 690

TYPE AAP/ABP	Rated Power		Nom. Speed rpm	Rated Current 400 V A	Nominal Moment Nm	Starting values				Overturning Moment Nom - Mom M _K /M _N	Efficiency			Power Factor Cosφ	Moment of Inertia kgm ²	Footed Motor Weight kg
	kW	HP				Current		Moment			100%	η				
						I _A /I _N λ	I _A /I _N Δ	M _A /M _N λ	M _A /M _N Δ			75%	50%			
132S6A	3	4	970	6,9	29,7	-	5,5	-	2,18	2,80	85,6	87,4	85,9	0,72	0,037	46,5
132M6A	4	5,5	965	8,75	39,6	-	5,6	-	2,20	2,70	86,8	87,6	86,7	0,75	0,051	53
132M6B	5,5	7,5	960	12,5	54,6	-	5,6	-	2,4	2,8	88,0	87,7	86,4	0,74	0,069	59,5
160M6A	7,5	10	975	16,2	73,5	-	6,3	-	2,0	3,3	89,1	89,8	88,5	0,74	0,110	92
160L6A	11	15	975	25,0	107,7	-	5,6	-	2,2	3,3	90,3	89,9	88,3	0,71	0,140	127
180L6A	15	20	975	30,0	147,0	-	6,00	-	2,5	2,7	91,2	91,0	90,8	0,73	0,220	203
200L6A	18,5	25	980	35,0	180,8	-	7,4	-	1,8	3,3	91,7	91,1	90,6	0,83	0,260	242
200L6B	22	30	975	43,0	215,0	-	7,00	-	2,6	3,2	92,2	91,6	91,0	0,80	0,320	248
225M6A	30	40	985	58,0	290,0	-	6,3	-	2,2	2,6	92,9	92,0	91,7	0,82	0,690	383
250M6A	37	50	985	69,5	360,0	-	7,00	-	2,8	2,6	93,3	92,1	91,5	0,82	0,990	455
280S6A	45	60	985	90,2	436,0	-	6,90	-	3,0	2,8	93,7	93,5	93,0	0,77	1,500	535
280M6A	55	75	985	109,8	530,0	-	7,30	-	3,3	3,2	94,1	93,3	92,6	0,78	1,700	575
315S6A	75	100	990	140,0	720,0	-	7,20	-	2,7	3,0	94,6	93,7	93,0	0,82	2,900	840
315M6A	90	120	990	166,0	865,0	-	7,20	-	2,7	3,0	94,9	94,0	93,3	0,83	3,500	882
315M6B	110	150	990	200,0	1060	-	7,20	-	2,7	3,0	95,1	95,1	94,5	0,83	4,200	930
315L6A	132	175	985	235,0	1285	-	7,20	-	2,5	2,8	95,4	94,9	94,0	0,86	5,500	955
315L6B	160	210	990	285,0	1545	-	7,00	-	2,4	3,2	95,6	95,1	94,8	0,83	6,800	1100
355M6A	160	220	990	306,0	1540	-	7,10	-	2,5	2,3	95,6	95,0	93,3	0,79	5,000	1065
355M6B	200	272	990	383,0	1930	-	7,10	-	2,5	2,4	95,8	95,0	93,5	0,81	6,800	1195
355M6C	250	340	985	472	2415	-	7,10	-	2,5	2,4	95,8	95,3	93,3	0,82	8,300	1405
355L6A	315	428	985	583	3040	-	7,10	-	2,5	2,4	95,8	95,1	93,0	0,83	10,700	1765
355L6B	355	483	985	650	3425	-	7,10	-	2,5	2,4	95,8	95,1	93,0	0,82	11,700	1905

IE3

3 PHASE, VOLTAGE : 460 V.
 FREQUENCY : 60 Hz.
 PROTECTION CLASS : IP 55
 INSULATION CLASS : F
 MODE OF OPERATION : S1

Synchronous Speed 3600 rpm

Δ 264 / Y 460

TYPE AAP	Rated Power		Nom. Speed rpm	Rated Current 460 V A	Nominal Moment Nm	Starting values				Overturning Moment Nom - Mom M _K /M _N	Efficiency η			Power Factor Cosφ	Moment of Inertia kgm ²	Footed Motor Weight kg
	kW	HP				Current I _A /I _N λ	I _A /I _N Δ	Moment M _A /M _N λ	Δ		100%	75%	50%			
80M2A	0,86	1,15	3460	1,60	2,4	7,5	-	2,9	-	3,2	77,0	75,8	74,6	0,83	0,00066	10
80M2B	1,27	1,70	3460	2,50	3,6	5,6	-	2,2	-	3,2	84,0	83,2	82,4	0,79	0,00080	11
90S2A	1,73	2,32	3455	3,45	4,8	7,2	-	4,1	-	4,3	85,5	84,7	84,0	0,74	0,00140	15,5
90L2A	2,53	3,39	3450	4,70	7,0	8,1	-	3,4	-	3,5	86,5	85,0	84,7	0,81	0,00170	16,5
100L2A	3,45	4,62	3490	6,1	9,4	7,0	-	2,3	-	3,2	88,5	87,6	86,3	0,82	0,00310	23

Synchronous Speed 3600 rpm

Δ 460 / Y 796

TYPE AAP/ABP	Rated Power		Nom. Speed rpm	Rated Current 460 V A	Nominal Moment Nm	Starting values				Overturning Moment Nom - Mom M _K /M _N	Efficiency η			Power Factor Cosφ	Moment of Inertia kgm ²	Footed Motor Weight kg
	kW	HP				Current I _A /I _N λ	I _A /I _N Δ	Moment M _A /M _N λ	Δ		100%	75%	50%			
132S2A	6,33	8,49	3515	10,0	17	-	7,5	-	3,1	4,3	89,5	88,1	87,2	0,90	0,0130	49
132S2B	8,60	11,5	3530	13,5	23	-	7,2	-	2,9	4,3	90,2	88,7	87,3	0,90	0,0170	55
160M2A	12,7	17,0	3545	19,7	34	-	6,5	-	2,1	2,7	91,0	90,6	88,5	0,88	0,0340	82
160M2B	17,3	23,0	3550	26,5	47	-	7,6	-	2,5	3,4	91,0	90,2	89,7	0,89	0,0460	90
160L2A	21,3	28,5	3545	32,6	57	-	8,2	-	2,6	3,2	91,7	90,6	90,0	0,91	0,0560	97
180M2A	25,3	34,4	3545	38,2	68	-	7,0	-	2,2	2,9	91,7	90,8	90,1	0,90	0,0750	180
200L2A	34,5	47,0	3560	52,0	92	-	8,5	-	3,1	3,9	92,4	90,9	90,1	0,92	0,1500	250
200L2B	42,5	58,0	3550	62,0	114	-	10,1	-	2,6	3,7	93,0	92,5	91,8	0,93	0,1700	265
225M2A	51,7	70,0	3545	77,5	139	-	8,70	-	2,6	2,9	93,6	92,6	92,0	0,92	0,2600	374
250M2A	63,2	86,0	3565	92,0	169	-	8,70	-	2,7	2,8	93,6	93,1	92,5	0,92	0,4700	460
280S2A	86,2	117,0	3575	127,0	231	-	8,0	-	2,7	3,0	94,1	93,8	93,1	0,91	0,6200	500
280M2A	103,0	140,8	3575	150,1	279	-	8,2	-	2,7	2,8	95,0	94,5	94,0	0,92	0,7400	575
315S2A	126,0	169,0	3575	186,0	341	-	8,0	-	2,3	2,8	95,0	94,6	94,3	0,90	1,2000	850
315M2A	152,0	206,4	3575	223,0	409	-	8,0	-	2,2	3,2	95,4	95,0	94,5	0,90	1,4000	870
315M2B	184,0	250,2	3575	265,0	491	-	8,0	-	2,3	2,8	95,8	95,1	94,5	0,91	1,5000	920
315L2A	212,0	289,3	3580	305,0	572	-	7,5	-	2,3	2,6	95,8	95,3	94,9	0,92	1,8500	1060
315L2B	230,0	312,8	3575	325,0	620	-	7,5	-	2,3	2,6	95,8	95,0	94,7	0,93	1,8000	1100
355M2A	287,5	462,0	3575	415	771	-	8,1	-	1,85	2,0	95,8	95,0	93,3	0,91	3,3000	1175
355M2B	362,3	585,0	3575	428	971	-	8,1	-	1,85	2,1	95,8	95,1	93,5	0,91	4,1000	1310
355M2C	408,2	657,0	3575	602	1091	-	8,2	-	1,85	2,1	95,8	95,0	93,5	0,90	4,5000	1375
355L2A	460,0	740,0	3575	670	1231	-	7,5	-	1,76	2,3	95,8	95,0	93,5	0,90	4,7000	1525
355L2B	517,5	832,0	3575	745	1389	-	7,5	-	1,85	2,3	95,8	95,0	93,6	0,90	5,3	1645

IE3

3 PHASE, VOLTAGE : 460 V.
 FREQUENCY : 60 Hz.
 PROTECTION CLASS : IP 55
 INSULATION CLASS : F
 MODE OF OPERATION : S1

Synchronous Speed 1800 rpm

Δ 264 / Y 460

TYPE AAP	Rated Power		Nom. Speed rpm	Rated Current 460 V A	Nominal Moment Nm	Starting values				Overturning Moment Nom - Mom M _r /M _N	Efficiency η			Power Factor Cosφ	Moment of Inertia kgm ²	Footed Motor Weight kg
	kW	HP				Current I _A /I _N		Moment M _A /M _N			100%	75%	50%			
						λ	Δ	λ	Δ							
80M4B	0,86	1,15	1720	1,90	4,8	5,7	-	2,3	-	2,5	83,5	84,9	83,6	0,70	0,0014	13,5
90S4A	1,27	1,70	1720	2,55	7,1	6,6	-	3,3	-	3,5	86,5	85,7	84,3	0,75	0,0025	17
90L4A	1,73	2,32	1740	3,40	9,5	6,5	-	2,5	-	3,5	86,5	85,8	85,1	0,75	0,0033	20
100L4A	2,53	3,39	1740	4,90	14	6,7	-	2,5	-	3,4	89,5	88,6	87,5	0,73	0,0052	26
100L4B	3,45	4,62	1740	6,40	19	6,9	-	2,3	-	3,2	89,5	88,1	87,6	0,77	0,0068	31

Synchronous Speed 1800 rpm

Δ 460 / Y 796

TYPE AAP / ABP	Rated Power		Nom. Speed rpm	Rated Current 460 V A	Nominal Moment Nm	Starting Values				Overturning Moment Nom - Mom M _r /M _N	Efficiency η			Power Factor Cosφ	Moment of Inertia kgm ²	Footed Motor Weight kg.
	kW	HP				Current I _A /I _N		Moment M _A /M _N			%100	%75	%50			
						λ	Δ	λ	Δ	M _r /M _N						
112M4A	4,60	6,17	1740	8,2	25	-	7,0	-	2,8	3,2	89,5	89,0	87,2	0,80	0,012	35
132S4A	6,33	8,49	1750	11,5	34	-	7,9	-	3,1	3,6	91,7	80,5	78,8	0,77	0,026	52
132M4A	8,60	11,5	1750	15,9	47	-	7,4	-	2,8	3,5	91,7	90,4	89,6	0,75	0,032	59
160M4A	12,7	17,0	1765	22,9	69	-	6,9	-	2,6	3,1	92,4	91,2	90,5	0,76	0,072	101
160L4A	17,3	23,0	1765	30,5	94	-	7,9	-	2,9	3,3	93,0	92,4	91,6	0,77	0,092	120
180M4A	21,3	30,0	1770	36,3	115	-	7,9	-	2,9	2,8	93,6	93,0	92,8	0,80	0,170	156
180L4A	25,3	34,5	1775	44,5	138	-	8,8	-	3,1	3,0	93,6	92,9	92,0	0,77	0,170	170
200L4A	34,5	47,0	1765	52,5	188	-	7,7	-	2,5	2,9	94,1	93,5	92,8	0,88	0,250	270
225S4A	42,5	58,0	1765	64,8	231	-	7,5	-	2,9	3,1	94,5	93,8	92,9	0,88	0,360	361
225M4A	51,7	70,0	1775	81,0	279	-	8,2	-	2,5	3,8	95,0	94,5	93,6	0,86	0,510	360
250M4A	63,2	86,0	1755	96,0	341	-	7,7	-	3,0	2,8	95,4	94,7	94,0	0,89	0,780	450
280S4A	86,2	115,0	1780	133,0	464	-	7,6	-	2,7	2,8	95,4	95,0	94,4	0,87	1,110	623
280M4A	103,0	138,0	1780	155,2	557	-	7,4	-	2,7	2,8	95,4	94,9	94,1	0,89	1,320	650
315S4A	126,0	169,0	1780	192,0	678	-	7,4	-	2,2	2,8	95,8	95,1	94,3	0,87	2,500	875
315M4A	152,0	206,0	1780	230,0	817	-	7,4	-	2,1	2,8	95,8	95,3	94,8	0,87	2,800	955
315M4B	184,0	250,0	1780	275,0	986	-	6,9	-	2,0	2,7	96,2	95,5	94,5	0,88	3,000	970
315L4A	212,0	289,0	1780	321,0	1147	-	6,9	-	2,0	2,7	96,2	95,5	95,0	0,87	3,100	1010
315L4B	230,0	313,0	1780	347,0	1236	-	5,2	-	1,9	2,9	96,2	95,6	95,1	0,87	3,300	1055
355M4A	287,5	462,0	1780	436,0	1548	-	6,5	-	1,9	2,6	96,2	95,0	94,3	0,88	5,500	1395
355M4B	362,3	585,0	1780	558	1942	-	7,0	-	1,9	2,6	96,2	95,0	94,1	0,88	6,000	1435
355M4C	408,2	657,0	1780	630	2188	-	7,0	-	2,3	2,6	96,2	95,0	94,3	0,88	6,500	1455
355L4A	460,0	740,0	1780	703	2471	-	7,1	-	2,3	2,4	96,2	95,0	94,5	0,88	7,200	1475
355L4B	517,5	832,0	1780	801	2774	-	7,1	-	2,4	2,4	96,2	95,0	94,5	0,88	8,200	1640

IE3

3 PHASE,
 VOLTAGE : 460 V.
 FREQUENCY : 60 Hz.
 PROTECTION CLASS : IP55
 INSULATION CLASS : F
 MODE OF OPERATION : S1

Synchronous Speed 1200 rpm

Δ 264 / Y 460

TYPE AAP	Rated Power		Nom. Speed rpm	Rated Current 460 V A	Nominal Moment Nm	Starting values				Overturning Moment Nom - Mom M_K/M_N	Efficiency η			Power Factor $\cos\phi$	Moment of Inertia kgm^2	Footed Motor Weight kg
	kW	HP				Current I_A/I_N		Moment M_A/M_N			100%	75%	50%			
						λ	Δ	λ	Δ							
90S6A	0,86	1,15	1130	2,05	7	3,9	-	1,8	-	2,2	82,5	81,9	81,3	0,65	0,0038	18
90L6A	1,27	1,70	1120	3,05	11	4,8	-	2,6	-	2,8	87,5	87,1	79,8	0,69	0,0051	20,5
100L6A	1,73	2,32	1130	3,60	15	5,0	-	2,2	-	2,8	88,5	88,1	87,8	0,70	0,0110	26
112M6A	2,53	3,39	1165	5,1	20	6,2	-	2,1	-	3,0	89,5	88,9	88,3	0,72	0,0160	28

Synchronous Speed 1200 rpm

Δ 460 / Y 796

TYPE AAP/ABP	Rated Power		Nom. Speed rpm	Rated Current 460 V A	Nominal Moment Nm	Starting values				Overturning Moment Nom - Mom M_K/M_N	Efficiency η			Power Factor $\cos\phi$	Moment of Inertia kgm^2	Footed Motor Weight kg
	kW	HP				Current I_A/I_N		Moment M_A/M_N			100%	75%	50%			
						λ	Δ	λ	Δ							
132S6A	3,45	4,62	1165	6,9	29	-	5,5	-	2,0	2,6	89,5	88,7	87,9	0,72	0,037	46,5
132M6A	4,60	6,17	1160	8,75	38	-	5,6	-	2,0	2,5	89,5	89,3	88,6	0,75	0,051	53
132M6B	6,33	8,49	1150	12,5	53	-	5,6	-	2,2	2,6	91,0	90,8	90,3	0,74	0,069	59,5
160M6A	8,60	11,5	1170	16,2	71	-	6,3	-	1,9	3,1	91,0	91,0	89,9	0,74	0,110	92
160L6A	12,7	17,0	1170	25,0	104	-	5,6	-	2,0	3,1	91,7	91,6	90,7	0,71	0,140	127
180L6A	17,2	23,0	1170	30,0	141	-	6,00	-	2,3	2,5	91,7	91,0	90,3	0,73	0,220	203
200L6A	21,3	29,0	1175	35,0	174	-	7,4	-	1,7	3,1	93,0	92,2	91,5	0,83	0,260	242
200L6B	25,3	34,5	1170	43,0	207	-	7,00	-	2,4	3,0	93,0	92,1	91,6	0,80	0,320	248
225M6A	34,5	47,0	1180	58,0	279	-	6,3	-	2,0	2,4	94,1	93,2	92,5	0,82	0,690	383
250M6A	42,5	58,0	1180	69,5	346	-	7,00	-	2,6	2,4	94,1	93,5	92,8	0,82	0,990	455
280S6A	51,7	70,0	1180	90,2	419	-	6,90	-	2,8	2,6	94,5	93,8	93,0	0,77	1,500	535
280M6A	63,2	86,02	1180	109,8	510	-	7,30	-	3,1	3,0	94,5	93,7	92,7	0,78	1,700	575
315S6A	86,2	117,3	1190	140,0	692	-	7,20	-	2,5	2,8	95,0	94,5	94,0	0,82	2,900	840
315M6A	103,0	138,0	1190	166,0	832	-	7,20	-	2,5	2,8	95,0	94,5	94,1	0,83	3,500	882
315M6B	126,0	169,0	1190	200,0	1019	-	7,20	-	2,5	2,8	95,8	95,1	94,8	0,83	4,200	930
315L6A	151,0	206,4	1180	235,0	1236	-	7,20	-	2,3	2,6	95,8	95,0	94,5	0,86	5,500	955
315L6B	184,0	250,2	1190	285,0	1486	-	7,00	-	2,2	3,0	95,8	95,0	94,3	0,83	6,800	1100
355M6A	184,0	300,0	1190	306,0	1481	-	7,10	-	2,3	2,1	95,8	94,5	93,1	0,79	5,000	1065
355M6B	230,0	370,0	1190	383,0	1856	-	7,10	-	2,3	2,2	95,8	94,5	93,2	0,81	6,800	1195
355M6C	287,5	462,0	1180	472	2322	-	7,10	-	2,3	2,2	95,8	95,0	93,2	0,82	8,300	1405
355L6A	362,2	583,0	1180	583	2923	-	7,10	-	2,3	2,2	95,8	95,0	93,0	0,83	10,700	1765
355L6B	402,1	657,0	1180	650	3293	-	7,10	-	2,3	2,2	95,8	95,0	93,0	0,82	11,700	1905

MULTI-SPEED MOTORS

"Multi speed motor" is the motor from which different speed and power are obtained from the same body with more than two different windings. They are usually produced as double speed because of the difficulty of efficiency and production.

Double speed asynchronous motors are the same as single-speed asynchronous motors in terms of construction and operation. Dual-speed motors are manufactured in two forms, according to the type of winding: Dahlander and two separate windings;

Dahlander Connection Motors

They are motors where two different speeds at only 1/2 ratio can be obtained from a single winding placed in the Stator. Motors with 4/2 and 8/4 pole in the performance figures table are Dahlander winding motors.

Motors with Two Separate Winding Connection

They are the motors where two different speeds can be obtained from two separate windings placed in the stator. Motors with 6/4 and 8/6 pole in the performance figures table are two separate winding motors. Dual-speed motors are designed according to two different applications including Variable Torque and Constant Torque;

Constant Moment, Double Speed Motors

Constant torque motors are used in applications that require high torque at start-up and constant torque in low speed. Compressors, machine tools, cranes, etc use such motors. The power and current of the motor changes in both speeds. High-speed power is great. According to moment formula $[M = 975 \cdot P/n]$ moment must be constant and the power at low speed must be low. The power at high speed must be higher. High torque at low speed required in this type of motors can be obtained by keeping the output power as high as possible. For Constant Moment applications, D/YY connection is made in Dahlander winding motors and Y/Y connection is made in two winding motors.

Variable Moment, Double Speed Motors

Variable torque motors are used in applications that do not require high torque at start-up and in applications that require decreasing in square of of the speed in low speed. Torque and power are high at high-speed and they are low at low-speed. For Variable Moment applications, Y/YY connection is made in Dahlander winding motors and Y/Y connection is made in two winding motors.

3-Phase, double-speed motor terminal connections

Dahlander Winding

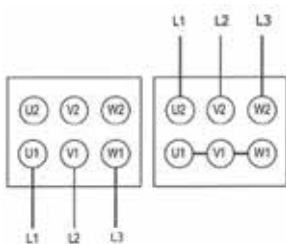

Low Speed High Speed

Two Separate Windings

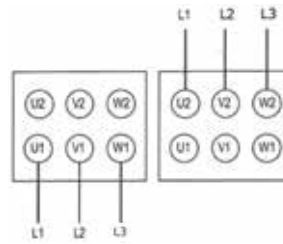

Low Speed High Speed

3 PHASE,
 VOLTAGE : 400 V.
 FREQUENCY : 50 Hz.
 PROTECTION CLASS : IP 55
 INSULATION CLASS : F
 MODE OF OPERATION : S1

Sync Speed 1500/3000 RPM [4/2 pole]

DAHLANDER CONNECTION (Δ / YY)

TYPE AB	Rated Power		Rated speed		Nominal Moment		Efficiency		Rated Current		Startup Values				Overturning Moment		B3 Motor Weight kg
	4k	2k	4k	2k	4k	2k	4k	2k	4k	2k	CURRENT		MOMENT		M _k /M _N	M _k /M _N	
											I _A /I _N	I _k /I _N	M _A /M _N	M _k /M _N			
71M4/2A	0.21	0.28	1340	2685	1.5	1	58.5	54.9	0.7	0.9	3	3.1	1.6	1.6	1.8	1.8	5
71M4/2B	0.3	0.43	1375	2765	2.1	1.5	65.2	61.4	0.9	1.23	3.7	3.8	1.8	1.8	2	2	6
80M4/2A	0.5	0.6	1380	2775	3.5	2.1	73	65.6	1.28	1.69	3.9	4	1.7	1.7	2	2	8
80M4/2B	0.7	0.85	1395	2840	4.8	2.8	73	65.4	1.637	2.03	4.3	4.3	1.8	1.8	2.1	2.1	10
90S4/2A	1.1	1.4	1385	2820	7.6	4.7	71.4	71.1	2.71	3.58	4.2	4.3	1.6	1.6	1.9	2	12
90L4/2A	1.5	1.9	1370	2830	10.5	6.4	73.5	74.5	3.62	4.4	4.9	5.3	1.9	1.9	2	2.1	15
100L4/2A	2	2.4	1400	2855	13.6	8.1	80	80	4.7	5.81	5	5	1.8	1.8	2.1	2.1	20
100L4/2B	2.6	3.1	1405	2875	17.7	10.3	79.2	77.3	5.82	7.48	5.6	5.6	2.3	2.4	2.4	2.4	22
112M4/2A	3.7	4.4	1405	2865	25.1	15	77	70.3	8.37	11.4	5.6	5.6	2	2.2	2.3	2.3	28
132S4/2A	4.9	5.9	1450	2905	32.3	19.4	80.1	73.8	10.8	13	6.3	6.3	1.7	1.6	2.2	2.2	38
132M4/2A	6.85	8	1430	2990	45.4	26.4	79	76.9	15	17	6.9	6.9	2	2.1	2.6	2.6	48
160M4/2A	9.5	11	1455	2920	62.4	36	85.3	82.3	19.9	22.1	6.7	6.7	2	1.8	2.4	2.4	71
160L4/2A	12	14.5	1455	2930	78.8	47.3	86.3	85.7	25	28.5	7.6	7.6	2.4	2.2	2.9	2.9	106
180M4/2A	15	18	1460	2940	98.1	58.5	84.9	81.5	31	37	6.7	6.7	2.1	2.2	3.2	3.2	163
180L4/2A	18	21.5	1460	2940	117.7	59.8	85.2	82.3	35	45	6.4	6.4	2	2.2	3.1	3.1	184

3 PHASE, VOLTAGE : 400 V.
 FREQUENCY : 50 Hz.
 PROTECTION CLASS : IP 55
 INSULATION CLASS : F
 MODE OF OPERATION : S1

Sync Speed 750 /1500 rpm [8/4/ pole]

DAHLANDER CONNECTION [Δ / YY]

TYPE AB	Rated Power		Rated speed		Nominal Moment		Efficiency		Rated Current		Startup Values				Overturning Moment		B3 Motor Weight kg
	8k	4k	8k	4k	8k	4k	8k	4k	8k	4k	CURRENT		MOMENT		M _k /M _N	M _k /M _N	
											I _A /I _N	I _A /I _N	M _A /M _N	M _A /M _N			
80M8/4A	0.18	0.32	670	1355	2.6	2.3	46.1	54.6	0.87	0.77	2.5	2.4	1.3	1.3	1.6	1.6	8
80M8/4B	0.25	0.4	670	1380	3.6	2.8	49	66	1.12	1.00	2.8	3.5	1.3	1.3	1.6	1.6	9
90S8/4A	0.35	0.5	675	1405	4.9	3.4	56.7	76.7	1.40	1.10	2.5	3.2	1.3	1.3	1.6	1.6	12
90L8/4A	0.5	0.7	640	1370	7.5	4.9	61.3	77	1.80	1.58	3.0	3.5	1.4	1.5	1.7	1.8	15
100L8/4A	0.7	1.1	675	1380	9.9	7.6	78	78	2.50	2.52	3.3	3.5	1.7	1.6	2	1.9	20
100L8/4B	0.9	1.5	700	1400	12.3	10.2	67.2	81.8	3.00	3.30	3.5	3.6	1.8	1.6	2	1.9	22
112M8/4A	1.4	2.2	710	1415	18.8	14.9	67.6	68.1	4.95	5.40	3.6	4.4	1.4	1.5	1.7	1.8	28
132S8/4A	1.8	3.	715	1415	24.1	20.3	72	81.3	6.0	6.3	4.3	5.4	2.0	1	2.3	1.8	33
132M8/4A	2.2	3.3	705	1420	29.8	22.2	73.8	79.9	6.5	7.0	4.2	5.2	2.0	1.3	2.3	1.8	40
132M8/4B	2.8	4.7	715	1430	37.4	31.4	73.4	81.3	9.2	10.0	4.3	5.4	2.0	1.3	2.3	1.8	50
160M8/4A	4.	6.5	710	1415	53.8	43.9	72.7	81.2	12.6	13.3	4.0	5.4	2.0	1.4	2.3	1.8	68
160L8/4A	5.1	10	730	1450	66.7	65.9	77.8	86	16.7	20.1	4.2	5.9	2.2	1.7	2.4	2	110
180L8/4A	10	16	730	1460	130.8	104.7	82.1	86	26.8	33.9	5.2	6.2	1.9	2	2.2	2.2	169
200L8/4A	15	19	740	1470	193.6	123.4	85.2	89	37	41	4.2	5.9	2.2	1.7	2.4	2	240
200L8/4B	16	24	745	1475	205.1	155.4	85.1	89.2	40	47	5.2	6.2	1.9	2	2.2	2.2	260

3 PHASE,
 VOLTAGE : 400 V.
 FREQUENCY : 50 Hz.
 PROTECTION CLASS : IP 55
 INSULATION CLASS : F
 MODE OF OPERATION : S1

Sync Speed 1000/1500 rpm [6/4 pole]
TWO SEPERATE WINDING [Y/Y]

TYPE AB	Rated Power		Rated speed d/d		Nominal Moment Nm		Efficiency		Rated Current A [400 V]		Startup Values				Overturning Moment		B3 Motor Weight kg
											CURRENT		MOMENT				
	6k	4k	6k	4k	6k	4k	6k	4k	6k	4k	6k	4k	6k	4k	6k	4k	
71M6/4A	0.12	0.18	940	1430	1.2	1.2	43.2	66.6	0.7	0.66	1.9	2.3	1.5	1.6	1.6	1.7	5
71M6/4B	0.18	0.22	890	1415	1.9	1.4	44.5	59.3	0.9	0.78	2	2.5	1.6	1.6	1.7	1.8	6
80M6/4A	0.22	0.32	956	1455	2.2	2.1	66.6	72.7	0.82	0.95	2.3	2.9	1.8	1.6	1.9	1.7	7
80M6/4B	0.26	0.4	930	1440	2.7	2.6	61.9	71.4	0.96	1.18	2.4	3	1.9	1.3	2	1.9	9
90S6/4A	0.38	0.65	905	1430	4	4.3	61.3	71.4	1.08	1.71	3	4.3	1.6	1.9	1.8	2.2	12
90L6/4A	0.55	0.9	905	1435	5.8	5.9	65.4	72	1.57	2.38	3.2	4.9	1.9	1.9	2	2.3	15
100L6/4A	0.9	1.3	920	1430	9.3	8.7	67.7	74.7	2.43	3.07	3.5	4.9	1.7	1.8	1.8	2.3	20
100L6/4B	1.1	1.7	930	1430	11.3	11.4	68.8	75.2	2.96	4.08	3.9	5	1.7	1.6	1.8	2	22
112M6/4A	1.5	2.3	960	1445	14.9	15.2	71.7	76.9	4.5	5.92	4.2	5	1.8	2	2.2	2.3	24
132S6/4A	2	3.1	955	1435	20	20.6	71.7	74.5	5.6	8	4.3	4.8	1.7	1.7	1.9	2	33
132M6/4A	2.8	4.3	945	1420	28.3	28.9	76.7	79.8	5.85	9.5	4.4	4.7	1.7	1.7	1.9	1.9	40
160M6/4A	4.3	6.6	960	1445	42.7	43.7	80.3	82.9	10.1	13.8	4.7	5.2	1.6	1.6	2	2.1	68
160L6/4A	5.7	8.7	960	1440	56.7	57.7	81.3	84	13.8	18	4.5	5	1.6	1.6	2.1	2	110
180L6/4A	9.5	15	985	1475	92.4	96.9	84.3	80	22	35.6	4.5	5	1.6	1.6	2	2	165

3 PHASE,
 VOLTAGE : 400 V.
 FREQUENCY : 50 Hz.
 PROTECTION CLASS : IP 55
 INSULATION CLASS : F
 MODE OF OPERATION : S1

Sync Speed 750/1000 rpm [8/6 pole]

TWO SEPERATE WINDING [Y/Y]

TYPE AB	Rated Power		Rated speed		Nominal Moment		Efficiency		Rated Current		Startup Values				Overturning Moment		B3 Motor Weight kg
	8k	6k	8k	6k	8k	6k	8k	6k	8k	6k	CURRENT		MOMENT		M _k /M _N	M _r /M _N	
											I _k /I _N	I _r /I _N	M _k /M _N	M _r /M _N			
80M8/6A	0.12	0.18	695	940	1.6	1.8	35.2	51.4	0.78	0.82	2.1	2.8	1.6	1.7	1.8	1.8	7
80M8/6B	0.18	0.28	670	945	2.6	2.5	47.4	61	0.85	0.95	2.1	2.8	1.6	1.7	1.8	1.8	9
90S8/6A	0.3	0.4	675	930	4.2	4.1	52.6	62.5	1.1	1.25	2.4	3.1	1.5	1.7	1.6	1.9	12
90L8/6A	0.4	0.55	680	925	5.6	5.7	54.8	62.5	1.60	1.7	2.5	3	1.7	1.6	1.8	1.8	15
100L8/6A	0.6	0.85	695	950	8.2	8.5	58.3	65.9	2.2	2.6	2.9	3.6	1.5	1.6	1.7	1.8	20
100L8/6B	0.8	1.1	680	935	11.1	11.1	60.31	66.2	2.9	3.3	2.9	3.4	1.5	1.6	1.8	1.8	22
112M8/6A	1.2	1.8	710	960	16.1	17.9	65.5	72	4.2	5.5	3.5	4.3	1.8	1.9	2	2.1	24
132S8/6A	1.5	2.2	715	955	20	22	62.6	72.6	5.5	6.2	3.3	3.8	1.6	1.6	1.9	1.8	33
132M8/6A	1.8	2.4	715	965	24	23.7	70.6	78.7	5.6	6.4	3.7	4.6	1.7	1.6	2	2.1	38
132M8/6B	2.3	3.3	710	950	30.9	33.2	71.7	77.5	6.8	8.3	3.7	4.2	1.7	1.6	1.9	1.9	40
160M8/6A	4	5.3	720	970	53.1	52.2	76.7	80.6	10.9	13.5	4.2	5	1.7	1.6	2	2	68
160L8/6A	5.4	7.2	725	965	71.1	71.3	79.6	81.4	14.7	16.4	5.1	5.1	2.1	1.7	2.5	2.2	110
180L8/6A	7.8	10.5	730	980	102	102.3	79.6	81.7	20.5	24.7	5.6	5.8	2.1	1.7	2.2	2.2	184

ALUMINIUM SERIES

IM B3

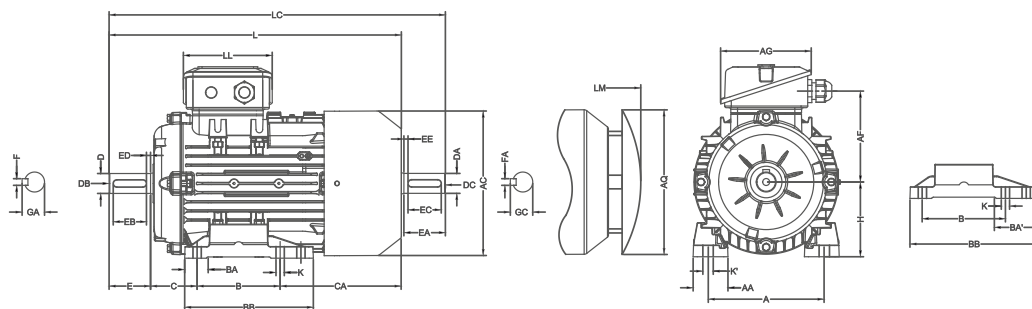

IM B5 and VI

See page 52 for flange dimensions

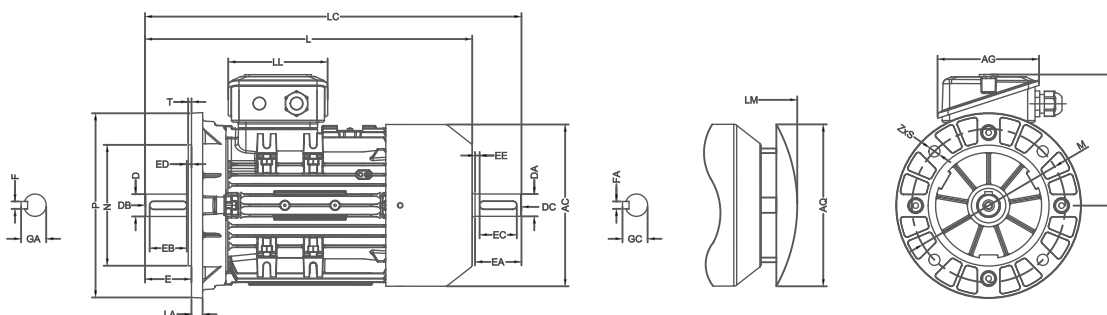

Structure Size	Number of poles	A	AA	AB	AC	AD	AF	AG	AQ	B	BA	BA'	BB	C	CA	H	K	K'
63M	2-4	100	28.5	123	125	108	87,5	60	--	80	30	30	100	40	71	63	7	10
71M	2-8	112	31	137	138.5	123	60	94	125	90	23	23	110	45	87	71	7	10
80M	2-8	125	35	150	156	132	68,5	94	125	100	34	34	125	50	100,5	80	10	13,5
80M Deep	2-8	125	35	150	156	132	68,5	94	125	100	34	34	125	50	122,5	80	10	13,5
90 S-L Short	2-8	140	41	174.5	174	141	82	94	160	100 125	26	51	154	56	78	90	10	12,5
90 S-L Long	2-8	140	41	174.5	174	141	82	94	160	100 125	26	51	154	56	121	90	10	12,5
90 S-L Deep	2-8	140	41	174,5	174	141	82	94	160	100 125	26	51	154	56	126	90	10	12,5
100L	2-8	160	46.5	195	195	161	93	102	160	140	44	44	174	63	131	100	12	16
100L Deep	2-8	160	46.5	195	195	161	93	102	160	140	44	44	174	63	181	100	12	16
112M	2-8	190	46	227.5	219.5	170	105	102	180	140	45	45	174	70	131,5	112	12	16
112M Deep	2-8	190	46	227.5	219,5	170	105	102	180	140	45	45	174	70	174	112	12	16
132 S-M Short	2-8	216	58	257	259	193	113	130	220	140 178	36	56	222	89	85	132	12.5	16.5
132 S-M Long	2-8	216	58	257	259	193	113	130	220	140 178	36	61	220	89	135	132	12.5	16.5
132 S-M Short Deep	2-8	216	58	257	259	193	113	130	220	140 178	36	61	222	89	97	132	12.5	16.5
132 S-M Long Deep	2-8	216	58	257	259	193	113	130	220	140 178	36	61	220	89	147	132	12.5	16.5
160 M-L Short	2-8	254	68	307	313.5	235	140	166	220	210 254	54	81	309	108	124	160	15	19
160 M-L Long	2-8	254	68	307	313.5	235	140	166	220	210 254	54	73	309	108	188	160	15	19
180 M-L	2-8	279	81	340	357	260	164	166	300	241 279	52	90	334	121	234	180	15	17
200L	2-8	318	81	375	387	282	215	186	--	305	64	64	366	133	229	200	19	24

ALUMINIUM SERIES

IM B35

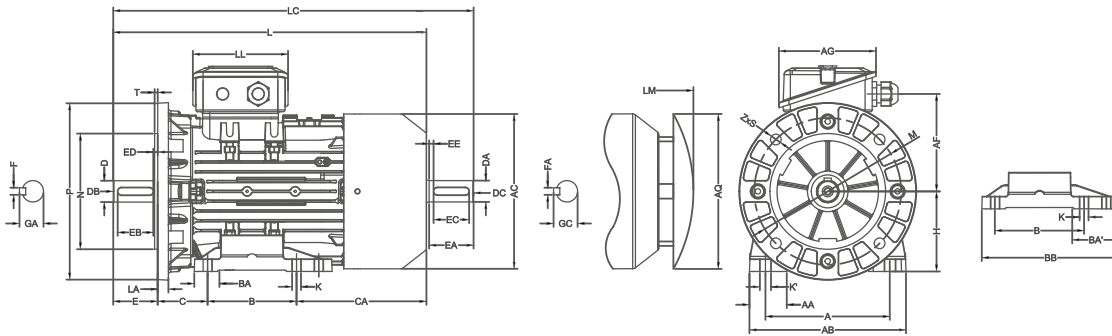

IM B14

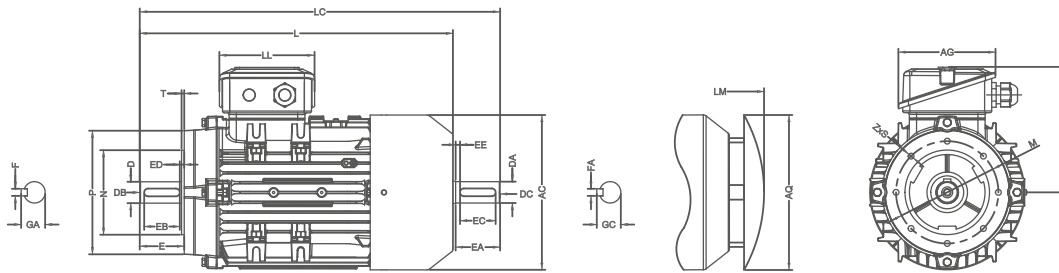

Structure Size	Number of poles	L	LC	LL	LM	D	DB	E	EB	ED	F	GA	DA	DC	EA	EC	EE	FA	GC
63M	2-4	214	242	95	243	11	M4	23	16	4	4	12,5	11	M4	23	16	4	4	12,5
71M	2-8	252	287	94	281	14	M5	30	22	4	5	16	14	M5	30	22	4	5	16
80M	2-8	290,5	335,5	94	317	19	M6	40	32	4	6	21,5	19	M6	40	32	4	6	21,5
80M Deep	2-8	312,5	357,5	94	339	19	M6	40	32	4	6	21,5	19	M6	40	32	4	6	21,5
90 S-L Short	2-8	256,5	311,5	94	191	24	M8	50	40	5	8	27	19	M8	40	32	4	6	21,5
90 S-L Long	2-8	352	407	94	386	24	M8	50	40	5	8	27	19	M8	40	32	4	6	21,5
90 S-L Deep	2-8	357	412	94	391	24	M8	50	40	5	8	27	19	M8	40	32	4	6	21,5
100L	2-8	394	459	102	428	28	M10	60	50	5	8	31	24	M8	50	40	5	8	27
100L Deep	2-8	444	509	102	478	28	M10	60	50	5	8	31	24	M8	50	40	5	8	27
112M	2-8	401,5	466,5	102	436	28	M10	60	50	5	8	31	24	M8	50	40	5	8	27
112M Deep	2-8	444	509	102	485	28	M10	60	50	5	8	31	24	M8	50	40	5	8	27
132 S-M Short	2-8	432	517	130	478	38	M12	80	70	5	10	41	38	M12	80	70	5	10	41
132 S-M Long	2-8	482	567	130	528	38	M12	80	70	5	10	41	38	M12	80	70	5	10	41
132 S-M Short Deep	2-8	444	529	130	490	38	M12	80	70	5	10	41	38	M12	80	70	5	10	41
132 S-M Long Deep	2-8	494	579	130	540	38	M12	80	70	5	10	41	38	M12	80	70	5	10	41
160 M-L Short	2-8	596	711	160	646	42	M16	110	90	10	12	45	42	M16	110	90	10	12	45
160 M-L Long	2-8	660	775	160	710	42	M16	110	90	10	12	45	42	M16	110	90	10	12	45
180 M-L	2-8	744	859	160	794	48	M16	110	90	5	14	51,5	42	M16	110	90	10	12	45
200L	2-8	777	892	186	--	55	M20	110	90	5	16	59	55	M20	110	90	5	16	59

Dimensions Aluminium Series

CAST SERIES

IM B3

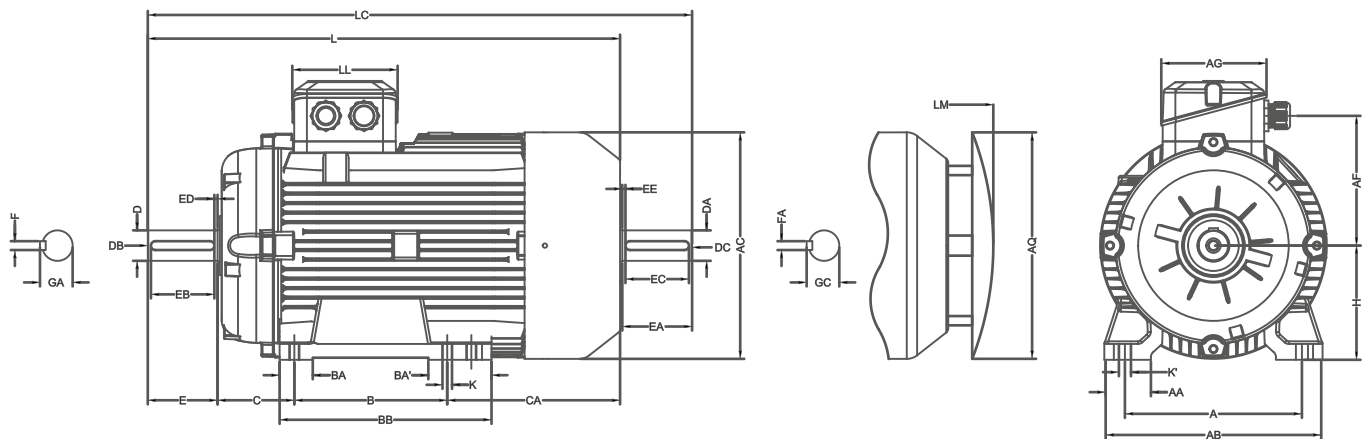

IM B5 ve V1

See page 52 for flange dimensions

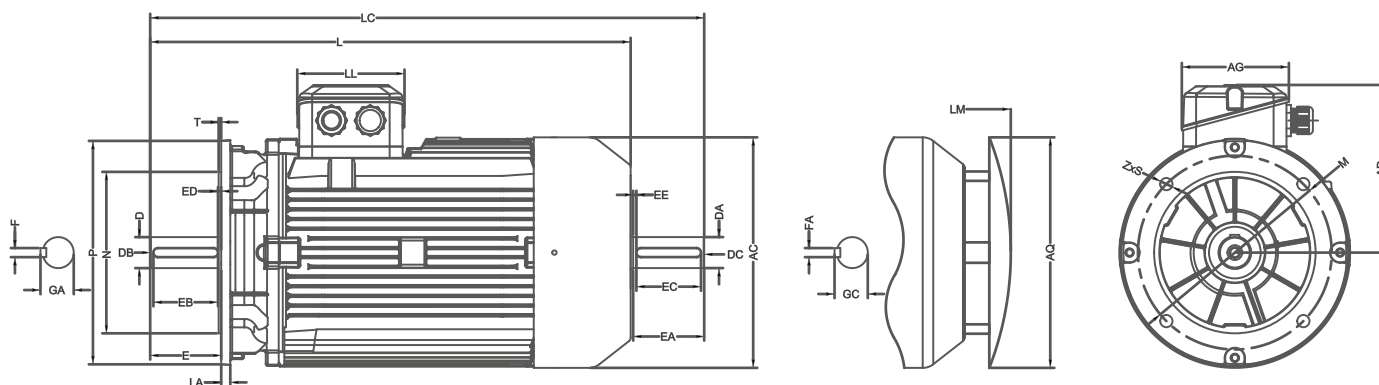

Structure Size	Number of poles	A	AA	AB	AC	AD	AF	AG	AQ	B	BA	BA'	BB	C	CA	H	K	K'
132 S-M Short	2-8	216	58	258	259	195	139	130	220	140 178	36	74	221	89	85	132	12.5	16.5
132 S-M Long	2-8	216	58	258	259	195	139	130	220	140 178	36	77	221	89	135	132	12.5	16.5
132 S-M Short Deep	2-8	216	58	258	259	195	113	130	220	140 178	36	61	221	89	97	132	12.5	16.5
132 S-M Long Deep	2-8	216	58	258	259	195	113	130	220	140 178	36	61	221	89	147	132	12.5	16.5
160 M-L Short	2-8	254	68	305.5	313.5	238	183	165	220	210 254	100	--	308	108	124	160	15	19
160 M-L Long	2-8	254	68	305.5	313.5	238	183	165	220	210 254	100	--	308	108	188	160	15	19
180 M-L	2-8	279	80.5	338.5	357	260	164	165	300	241 279	52	90	334	121	234	180	15	17

CAST SERIES

IM B35

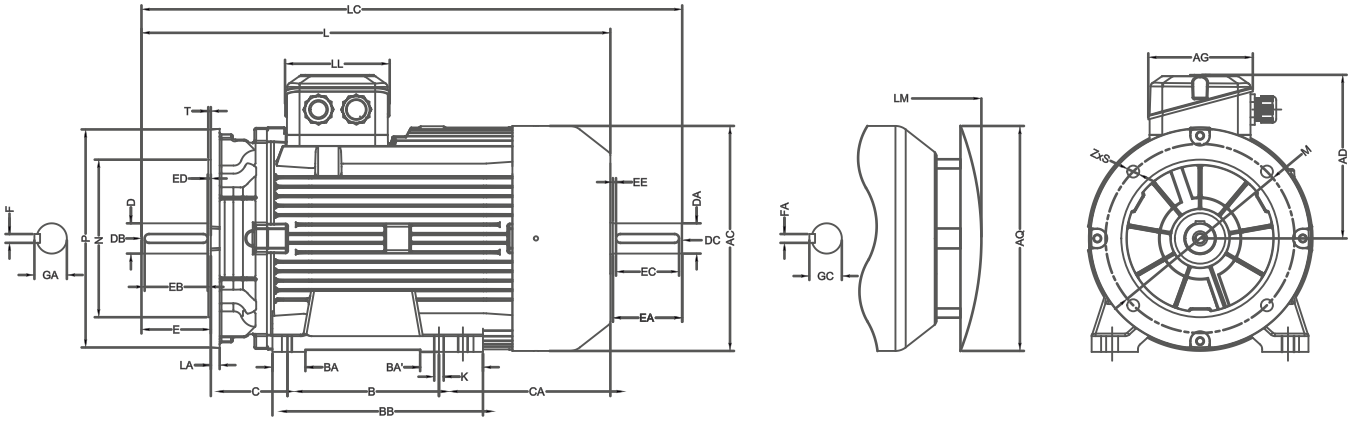

IM B14

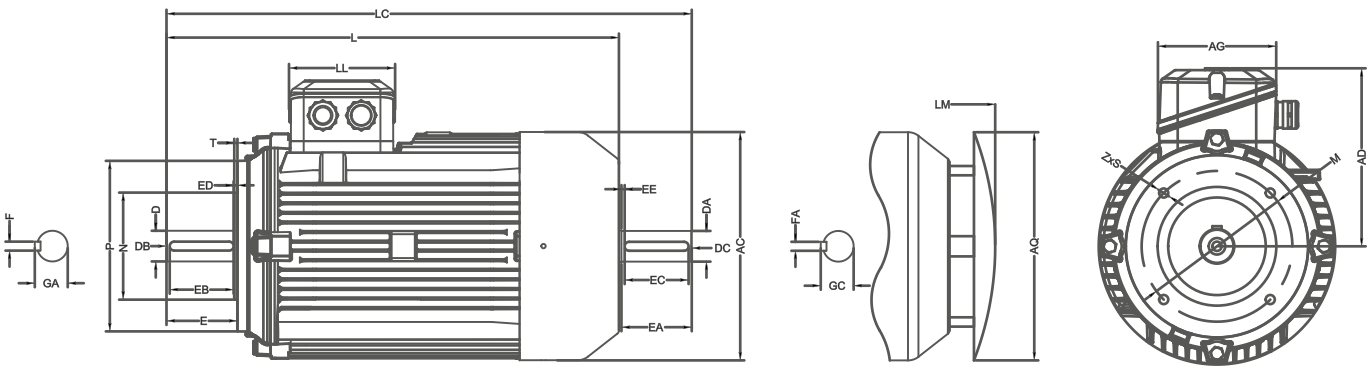

Structure Size	Number of poles	L	LC	LL	LM	D	DB	E	EB	ED	F	GA	DA	DC	EA	EC	EE	FA	GC
132 S-M Short	2-8	432	517	130	478	38	M12	80	70	5	10	41	38	M12	80	70	5	10	41
132 S-M Long	2-8	482	567	130	528	38	M12	80	70	5	10	41	38	M12	80	70	5	10	41
132 S-M Short Deep	2-8	444	529	130	490	38	M12	80	70	5	10	41	38	M12	80	70	5	10	41
132 S-M Long Deep	2-8	494	579	130	540	38	M12	80	70	5	10	41	38	M12	80	70	5	10	41
160 M-L Short	2-8	596	711	165	642	42	M16	110	90	10	12	45	42	M16	110	90	10	12	45
160 M-L Long	2-8	660	775	165	710	42	M16	110	90	10	12	45	42	M16	110	90	10	12	45
180 M-L	2-8	744	859	165	794	48	M16	110	90	5	14	51,5	42	M16	110	90	10	12	45

CAST IRON SERIES

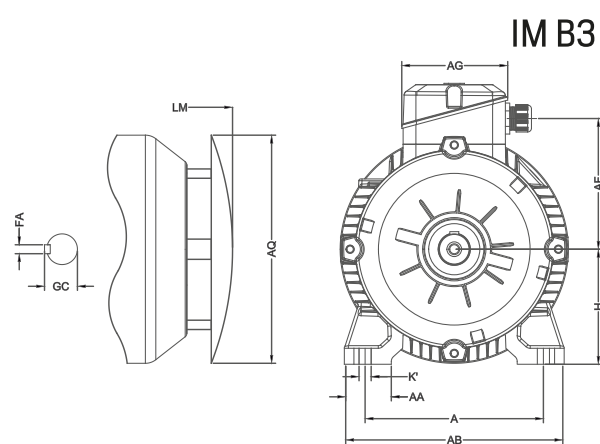
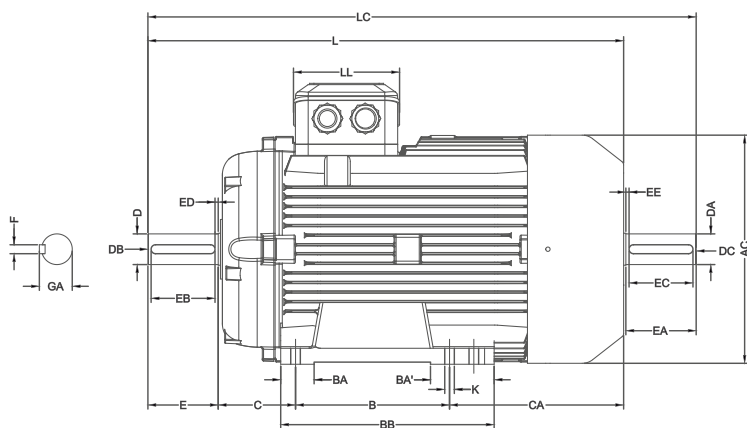

IM B5 ve V1

See page 52 for flange dimensions

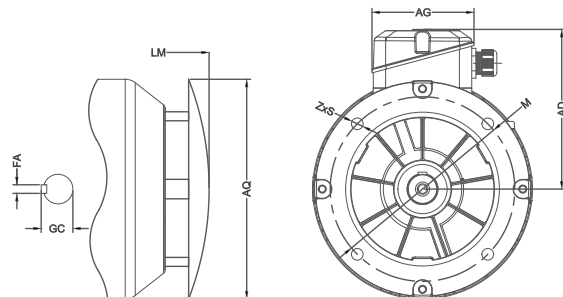
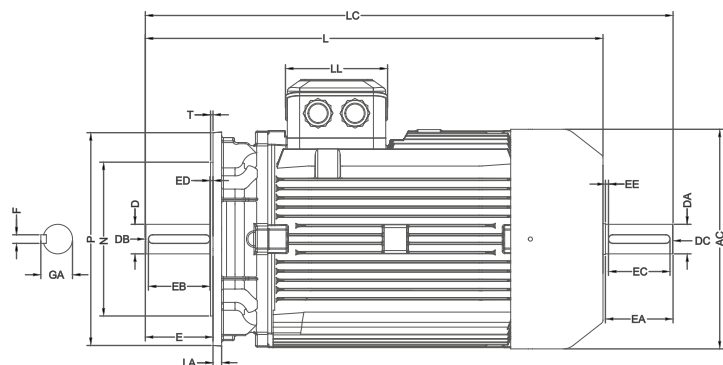

Dimensions Aluminium Series

Structure Size	Number of poles	A	AA	AB	AC	AD	AF	AG	AQ	B	BA	BA'	BB	C	CA	H	K	K'
180 M-L	2-6	279	73.5	344	357	260	204.5	165	300	241 279	50	97	334	121	234	180	15	17
200L	2-6	318	84.5	388	386.5	284	231	186	--	305	66	104	365	133	229	200	19	19
225 S-M	2 4-6	356	82	438	432.5	313	255	186	--	286 311	60	85	369	149	225	225	19	24
225 S-M Deep	2 4-6	356	82	438	432.5	313	255	186	--	286 311	60	85	369	149	309	225	19	24
250 M	2-6	406	92	486	480	337	278	198	--	349	79	79	412.5	168	201,5	250	25	30
250 M Deep	2-6	406	92	486	480	337	278	198	--	349	79	79	412.5	168	277	250	25	30
280 S-M	2 4-6	457	120	550	547.5	398	321	259	--	368 419	115	155	505	190	223	280	23	25
315 S-M	2	508	126	610	627	485	392	330	--	406 457	141.5	156	574	216	267	315	28	43
315 S-M	4 6	508	126	610	627	485	392	330	--	406 457	141.5	156	574	216	267	315	28	43
315 M-L	2	508	126	610	627	485	392	330	--	457 508	141.5	156	625	216	336	315	28	43
315 M-L	4 6	508	126	610	627	485	392	330	--	457 508	141.5	156	625	216	336	315	28	43
355 M-L	2 4-6	610	160	756	725	538	--	326	--	560 630	170	118	1000	254	306	355	28	28

CAST IRON SERIES

IM B35

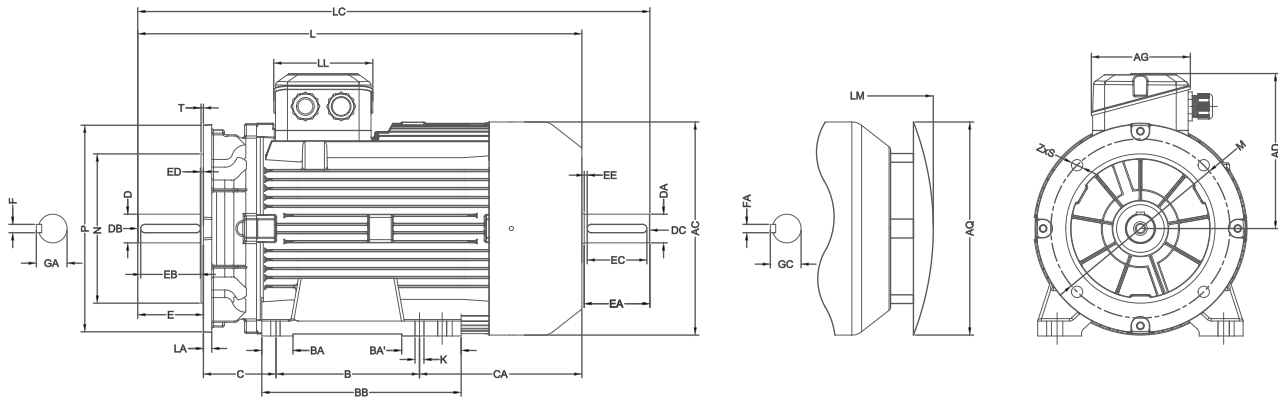

Structure Size	Number of poles	L	LC	LL	LM	D	DB	E	EB	ED	F	GA	DA	DC	EA	EC	EE	FA	GC
180 M-L	2-6	744	859	165	794	48	M16	110	90	5	14	51.5	42	M16	110	90	10	10	41
200L	2-6	777	892	186	--	55	M20	110	90	5	16	59	55	M20	110	90	5	16	59
225 S-M Deep	2	795	910	186	--	55	M20	110	100	5	16	59	55	M20	110	100	5	16	59
	4-6	825	970	186	--	60	M20	140	125	10	18	64	55	M20	110	100	5	16	59
225 S-M	2	879	994	186	--	55	M20	110	100	5	16	59	55	M20	110	100	5	16	59
	4-6	909	1054	186	--	60	M20	140	125	10	18	64	55	M20	110	100	5	16	59
250 M	2	858,5	1003,5	198	--	60	M20	140	125	10	18	64	55	M20	110	100	5	16	59
	4-6	--	--	--	--	65	M20	140	125	10	18	69	60	M20	140	125	10	18	64
250 M Deep	2	934	1079	198	--	60	M20	140	125	10	18	64	55	M20	110	100	5	16	59
	4-6	--	--	--	--	65	M20	140	125	10	18	69	60	M20	140	125	10	18	64
280 S-M	2	972	1117	259	--	65	M20	140	125	10	18	69	60	M20	140	125	10	18	64
	4-6	--	--	--	--	75	M20	140	125	10	20	79.5	65	M20	140	125	10	18	69
315 S-M	2	1080	1225	330	--	65	M20	140	125	10	18	69	60	M20	140	125	10	18	64
315 S-M	4-6	1110	1285	330	--	85	M20	170	140	25	22	90	70	M20	140	125	10	20	74.5
315 M-L	2	1200	1345	330	--	65	M20	140	125	10	18	69	60	M20	140	125	10	18	64
315 M-L	4-6	1230	1405	330	--	85	M20	170	140	25	22	90	70	M20	140	125	10	20	74.5
355 M-L	2	1630	1805	425	--	80	M20	170	140	25	22	85	80	M20	170	140	10	22	85
	4-6	1670	1885	--	--	100	M24	210	180	25	28	106	100	M24	210	180	10	28	106

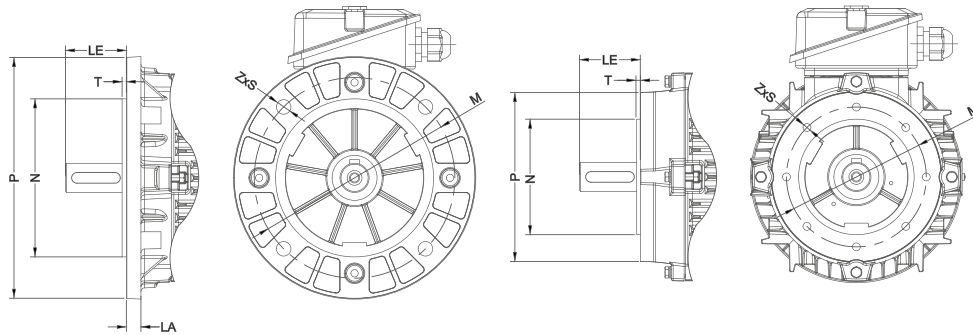

Building Size	Construction Type	Flange Type	DIN 42948	LA	LE	M	N	P	S	T	Z
63 M	IM B14-IMB34-V18-V19	Standart Flange	C 90	--	23	75	60	90	M5	2.5	8
	IM B14-IMB34-V18-V19	Special Flange	C 120	--	23	100	80	120	M6	3	4
	IM B14-IMB34-V18-V19	Special Flange	C140	8	23	115	95	140	M6	3	4
71 M	IM B5-IM B35-V1-V3	Standart Flange	A 160	9	30	130	110	160	10	3.5	4
	IM B14-IMB34-V18-V19	Standart Flange	C 105	--	30	85	70	105	M6	2.5	8
80 M	IM B5-IM B35-V1-V3	Standart Flange	A 200	10	40	165	130	200	12	3.5	4
	IM B14-IMB34-V18-V19	Standart Flange	C 120	--	40	100	80	120	M6	3	8
90 S-90 L	IM B5-IM B35-V1-V3	Standart Flange	A 200	10	50	165	130	200	12	3.5	4
	IM B14-IMB34-V18-V19	Standard Flange	C 140	--	50	115	95	140	M8	3	8
	IM B14-IMB34-V18-V19	Special Flange	C 120	--	40	100	80	120	M6	3	8
	IM B14-IMB34-V18-V19	Special Flange	C 160	--	50	130	110	160	M8	3.5	8
100 L	IM B5-IM B35-V1-V3	Standart Flange	A 250	11	60	215	180	250	15	4	4
	IM B14-IMB34-V18-V19	Standart Flange	C 160	--	60	130	110	160	M8	3.5	8
112 M	IM B5-IM B35-V1-V3	Standart Flange	A 250	11	60	215	180	250	15	4	4
	IM B14-IMB34-V18-V19	Standart Flange	C 160	--	60	130	110	160	M8	3.5	8
132 S-132 M	IM B5-IM B35-V1-V3	Standart Flange	A 300	12	80	265	230	300	15	4	4
	IM B14-IMB34-V18-V19	Standart Flange	C 200	--	80	165	130	200	M10	3.5	4
	IM B5-IM B35-V1-V3	Special Flange	A 250	13	80	215	180	250	15	4	4
160 M-160 L	IM B5-IM B35-V1-V3	Standart Flange	A 350	13	110	300	250	350	19	5	4
	IM B14-IMB34-V18-V19	Standart Flange	C 200	--	110	165	130	200	M10	3.5	4
180 M-180 L	IM B5-IM B35-V1-V3	Standart Flange	A 350	13	110	300	250	350	19	5	4
200 L	IM B5-IM B35-V1-V3	Standart Flange	A 400	15	110	350	300	400	19	5	4
225 S-225 M											
2 Pole	IM B5-IM B35-V1-V3	Standart Flange	A 450	16	110	400	350	450	19	5	8
4.6 Pole					140						
250 M	IM B5-IM B35-V1-V3	Standart Flange	A 550	18	140	500	450	550	19	5	8
280 S-280 M	IM B5-IM B35-V1-V3	Standart Flange	A 550	18	140	500	450	550	19	5	8
315 S- M											
315 L	IM B5-IM B35-V1-V3	Standart Flange	A 660	22	140	600	550	660	24	6	8
2 .4.6 Pole					170						
355 ML	IM B5-IM B35-V1-V3	Standart Flange	A800	30	170	740	680	800	24	6	8
2.4.6 Pole					210						

MARINE MOTORS

Marine motors produced for marine industry practice are specially produced to operate under marine conditions. Standard electric motors are designed to operate in the marine environment and produced at a proportion of properties as described below.

- All bolts and fasteners are from corrosion free material
- Body cover, flanges, terminal box and cover are from cast material
- Fittings are optionally made of brass or bronze
- Standard thermistor is [PTC] applied
- Varnish used in winding is from high temperature-resistant material
- Stump [no fan and unshielded fan] for the purpose of impermeability
- Standard protection class is IP 56 class that allows high water resistance
- Paints are epoxy polyester primer and finish is painted
- If desired, in a form encoder can be connected to the motors
- If necessary, they are produced as heater placed in the motor windings.

SPECIAL WINDING MOTORS

Power and operating values of 3-phase asynchronous electric motors produced by I-MAK are valid under conditions of continuous operation [SI] and a rated voltage of 400 V + - 5%, 50 Hz FREQUENCY, ambient temperature of maximum 40 °C and elevation from the sea level up to 1000 m.

At a frequency of 50 Hz, motors are compatible with Δ 230V/Y400V connection at power 3 kW and lower and Δ 400V / Y690V connection at power 4 kW and over. Standard motors can be designed so as to operate at 50 Hz, 400V and 60 Hz, 460V or at requested voltage [24V, 48V, 500V, etc.] or frequency [17 Hz, 87 Hz, and so on] for non-standard applications by experienced specialized staff.

BRAKE MOTORS

EN 60034-1 compliant 63-355 body brake motors;

General Applications

- Automation Systems
- Gearboxes
- Fans
- Crushers
- Conveyor Belts[conveyor]
- Centrifuge Machines
- Presses
- Lift Applications
- Crane Applications
- Packaging Machinery
- Automatic Sliding Systems
- Stone crushing, screening machines and so on.

Standard Features

- Brake Voltage: 24 or 220 V DC
- Braking torque Range: 3 - 2800 Nm
- 3-phase Squirrel Cage Induction Motors
- Output Power: 0,12 - 450 kW
- Protection Class IP55
- Frame Size 63 - 355
- Voltage & Frequency: 230 /400-400 / 690 [50 Hz]
- Insulation class: F [AT=80 K]
- Mode of Operation: S1
- Operating Temperature: Maximum 40 °C [up to 1000 m above sea level]
- Squirrel-cage rotor, Aluminum Injection
- Double lip seals on both sides
- Stainless steel nameplate
- IEC - 72 Compliant Construction Sizes
- Performance Characteristics According to IEC-34
- Cable Access Threaded in Terminal Box In Compliance with Metric Values
- Colour: RAL 7030 or 5023
- IEC-411 Compliant Cooling
- Fixed Foot

Special Applications

- Protection Class: IP56-IP65-IP66
 - Special bearings
 - Special Seals
 - Thermal Protection
 - Thermal
 - PT100
 - H Insulation
 - Special winding [Special Voltage & Frequency]
- Please consult regarding different applications as needed.

CINICI MOTORS

Pressure water pump motors with construction sizes IEC112, 132, 160 and power of 1500 rpm and 4,00-5,50-7,50-11,00-15,00 kW are especially used in washing machines. Drive side of the shaft of these motors has hollow shaft and have specially designed bearing and cover.

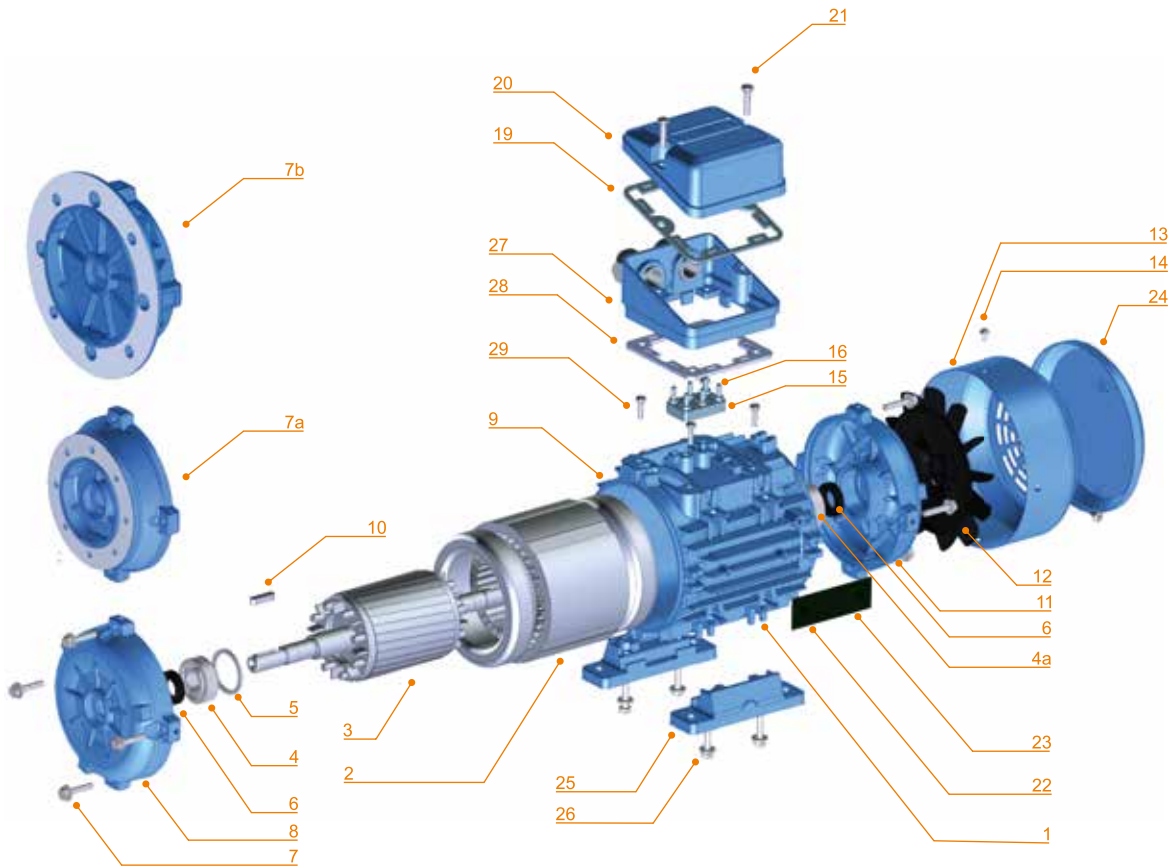

NO	Number of poles
----	-----------------

01	Frame
02	Completwinding stator [varnished]
03	Rotor shaft [balanced]
04	DE Bearing
04a	NDE Bearing
05	Bearing tension spring
06	Wiper
07	DE Shield
07a	B14 Flange
07b	B5 Flange
08	Connection bolt
09	Connection bolt nut
10	Shaft end wedge
11	NDE Shield
12	propeller
13	Propeller protection cup
14	Propeller protection cup bolt
15	Terminals [terminals, bridges, nuts and washers included]

NO	Number of poles
----	-----------------

16	Terminal connection bolt
17	Earth connection
18	Earth connection bolt
19	Gasket
20	The terminal box cover
21	The terminal box cover mounting bolt
22	Label
23	Label connection bolt
24	Canopy [rain protection]
25	Feet
26	Feet mounting bolt
27	Terminal box
28	Terminal box Seal Ring
29	Terminal box Mounting Screw

DE: Drive end NDE: Non Drive End



GEARBOX & VARIATOR CO.

SIPCO i.Mak[®]
Gearboxes and Drives

12610 Old Galveston Road, Webster (Houston) TX 77598, USA
P: +1.281.480.8711
info@sipco-imak.com

www.sipco-imak.com