

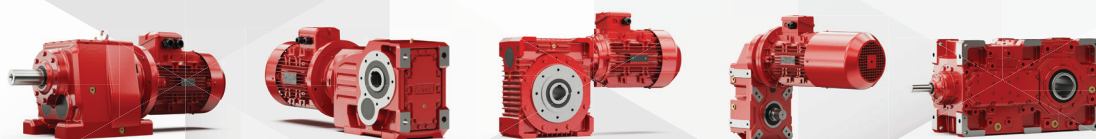

Gearboxes and Drives

*Driven by passion*

SC00



2024

EN | FR

Gearboxes and Drives / Moto Réducteurs

**Applications Sector**  
*Secteurs et Industries*



**Steel**  
*Metallurgie et Siderurgie*



**Mines and Quarries**  
*Mines et Carrieres*



**Gas and Petroleum**  
*Gaz et Hydrocarbures*



**Marine**  
*Marin*



**Water Treatment**  
*Traitement des Dechets et Eaux Usees*

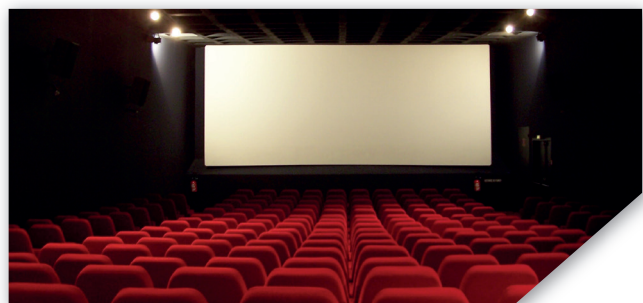

**Stage and Theater**  
*Scene et Theatre*



**Food and Beverage**  
*Agroalimentaire*



**Agriculture and Forestry**  
*Agro-Alimentaire*

<b>İR Serisi Redüktörlerin Genel Özellikleri</b> Descriptions and Specifications of the İR Serie / <i>Descriptions et specifications de la serie İR</i>	<b>1-4</b>
<b>İRF Serisi Redüktörlerin Genel Özellikleri</b> Descriptions and Specifications of the İRF Serie / <i>Descriptions et specifications de la serie İRF</i>	<b>5-8</b>
<b>İRO Serisi Redüktörlerin Genel Özellikleri</b> Descriptions and Specifications of the İRO Serie / <i>Descriptions et specifications de la serie İRO</i>	<b>9-10</b>
<b>İRNX Serisi Redüktörlerin Genel Özellikleri</b> Descriptions and Specifications of the İRNX Serie / <i>Descriptions et specifications de la serie İRNX</i>	<b>11-12</b>
<b>YP Serisi Redüktörlerin Genel Özellikleri</b> Descriptions and Specifications of the YP Serie / <i>Descriptions et specifications de la serie YP</i>	<b>13-16</b>
<b>YPF Serisi Redüktörlerin Genel Özellikleri</b> Descriptions and Specifications of the YPF Serie / <i>Descriptions et specifications de la serie YPF</i>	<b>17-20</b>
<b>İRCM Serisi Redüktörlerin Genel Özellikleri</b> Descriptions and Specifications of the İRCM Serie / <i>Descriptions et specifications de la serie İRCM</i>	<b>21-22</b>
<b>İRKM Serisi Redüktörlerin Genel Özellikleri</b> Descriptions and Specifications of the İRKM Serie / <i>Descriptions et specifications de la serie İRKM</i>	<b>23-26</b>
<b>İRKF Serisi Redüktörlerin Genel Özellikleri</b> Descriptions and Specifications of the İRKF Serie / <i>Descriptions et specifications de la serie İRKF</i>	<b>27-30</b>
<b>SM Serisi Redüktörlerin Genel Özellikleri</b> Descriptions and Specifications of the SM Serie / <i>Descriptions et specifications de la serie SM</i>	<b>31-32</b>
<b>SFM Serisi Redüktörlerin Genel Özellikleri</b> Descriptions and Specifications of the SFM Serie / <i>Descriptions et specifications de la serie SFM</i>	<b>33-34</b>
<b>İRSAM Serisi Redüktörlerin Genel Özellikleri</b> Descriptions and Specifications of the İRSAM Serie / <i>Descriptions et specifications de la serie İRSAM</i>	<b>35-36</b>
<b>İRSFM Serisi Redüktörlerin Genel Özellikleri</b> Descriptions and Specifications of the İRSFM Serie / <i>Descriptions et specifications de la serie İRSFM</i>	<b>37-38</b>
<b>İRSAM 201-250 Serisi Redüktörlerin Genel Özellikleri</b> Descriptions and Specifications of the İRSAM 201-250 Serie / <i>Descriptions et specifications de la serie İRSAM 201-250</i>	<b>39</b>

<b>İRSFM 201-250 Serisi Redüktörlerin Genel Özellikleri</b> Descriptions and Specifications of the İRSFM 201-250 Serie / <i>Descriptions et specifications de la serie İRSFM 201-250</i>	40
<b>İRSDM Serisi Redüktörlerin Genel Özellikleri</b> Descriptions and Specifications of the İRSDM Serie / <i>Descriptions et specifications de la serie İRSDM</i>	41-42
<b>İRSDFM Serisi Redüktörlerin Genel Özellikleri</b> Descriptions and Specifications of the İRSDFM Serie / <i>Descriptions et specifications de la serie İRSDFM</i>	43-44
<b>MAM 02-03 Serisi Redüktörlerin Genel Özellikleri</b> Descriptions and Specifications of the MAM 02-03 Serie / <i>Descriptions et specifications de la serie MAM 02-03</i>	45-48
<b>MAM 04 Serisi Redüktörlerin Genel Özellikleri</b> Descriptions and Specifications of the MAM 04 Serie / <i>Descriptions et specifications de la serie MAM 04</i>	49-50
<b>MKM 03-04 (G09) Serisi Redüktörlerin Genel Özellikleri</b> Descriptions and Specifications of the MKM 03-04 (G09) Serie / <i>Descriptions et specifications de la serie MKM 03-04 (G09)</i>	51-54
<b>MKM 03 (G10) Serisi Redüktörlerin Genel Özellikleri</b> Descriptions and Specifications of the MKM 03 (G10) Serie / <i>Descriptions et specifications de la serie MKM 03 (G10)</i>	55-57
<b>4DSM Serisi Redüktörlerin Genel Özellikleri</b> Descriptions and Specifications of the 4DSM Serie / <i>Descriptions et specifications de la serie 4DSM</i>	58
<b>A 200 Serisi Redüktörlerin Genel Özellikleri</b> Descriptions and Specifications of the A 200 Serie / <i>Descriptions et specifications de la serie A 200</i>	59
<b>2A 200 Serisi Redüktörlerin Genel Özellikleri</b> Descriptions and Specifications of the 2A 200 Serie / <i>Descriptions et specifications de la serie 2A 200</i>	60
<b>2A Serisi Redüktörlerin Genel Özellikleri</b> Descriptions and Specifications of the 2A Serie / <i>Descriptions et specifications de la serie 2A</i>	61
<b>3A Serisi Redüktörlerin Genel Özellikleri</b> Descriptions and Specifications of the 3A Serie / <i>Descriptions et specifications de la serie 3A</i>	62
<b>3A 750 Serisi Redüktörlerin Genel Özellikleri</b> Descriptions and Specifications of the 3A 750 Serie / <i>Descriptions et specifications de la serie 3A 750</i>	63
<b>4A 750 Serisi Redüktörlerin Genel Özellikleri</b> Descriptions and Specifications of the 4A 750 Serie / <i>Descriptions et specifications de la serie 4A 750</i>	64

■ IR ...

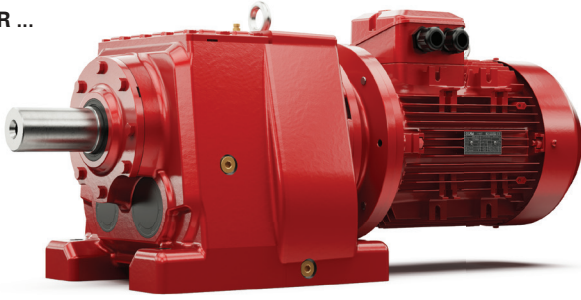

■ IRO ...



■ YP ...



■ IRNX ...



■ IRK ...

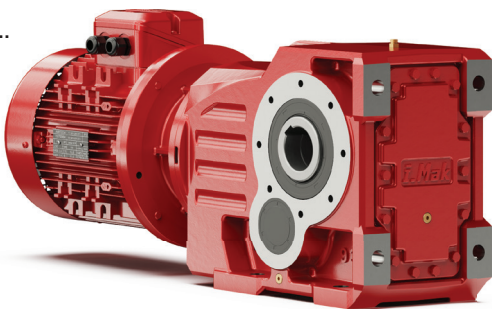

■ IRC ...

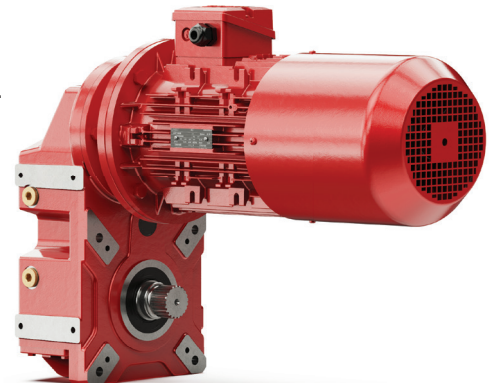

■ S ...

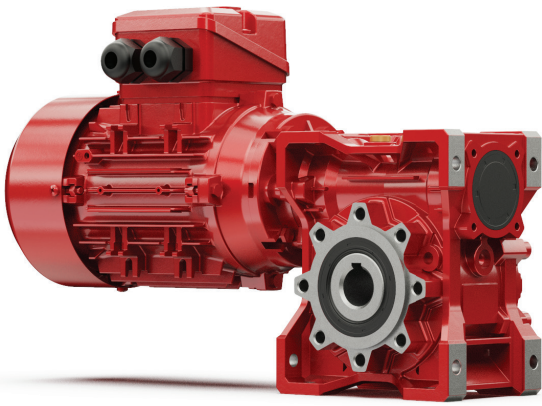

■ MA ...

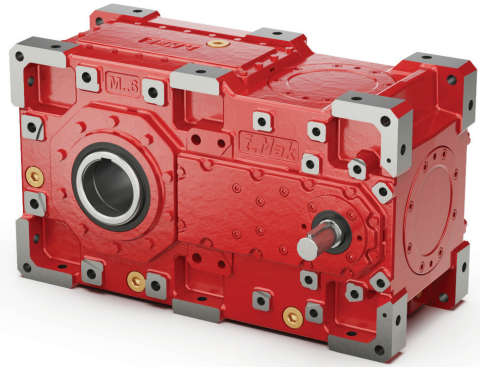

■ IRS ...

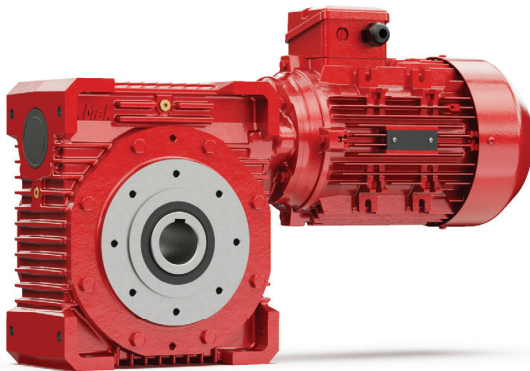

■ MK ...

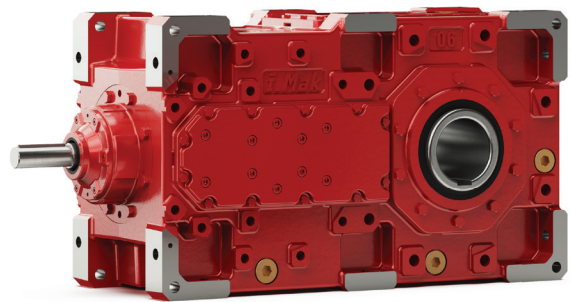

■ IRSD ...

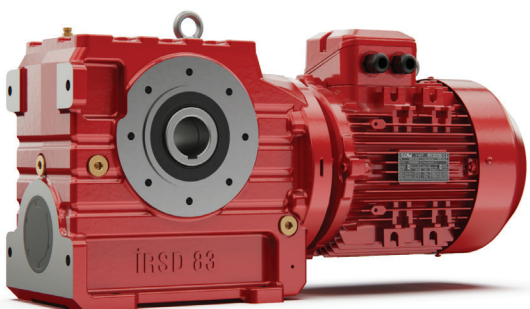

■ MAE / MKE ...

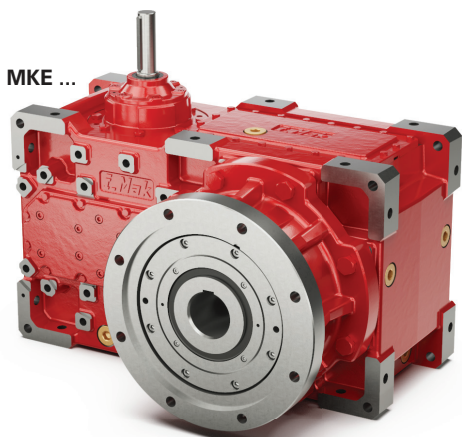

Available in one or two stage of gears, the IR Series gearboxes provide optimal solutions for a large range of application. The unicast housing of the gearbox and the gears technology is offering a perfect balance between power and space optimization.

*Disponibles dans une large gamme de dimensions et de rapports de réduction, les motoréducteurs de la série IR sont utilisables dans de nombreuses situations. Particulièrement adaptés aux applications avec de fortes charges radiales, les motoréducteurs de la série IR sont disponibles dans des dimensions allant de 42 à 153 cm, assurant ainsi leur grande polyvalence.*

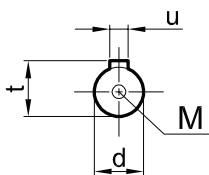
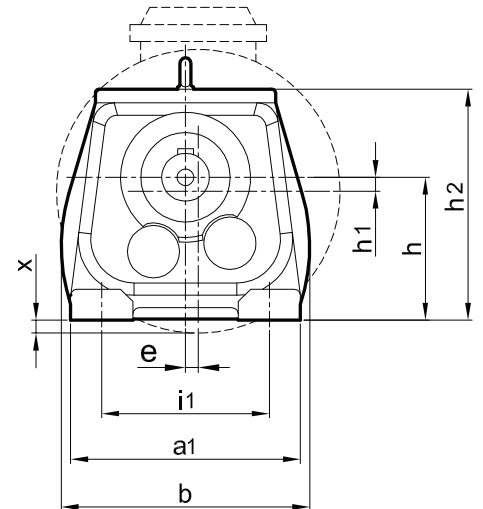
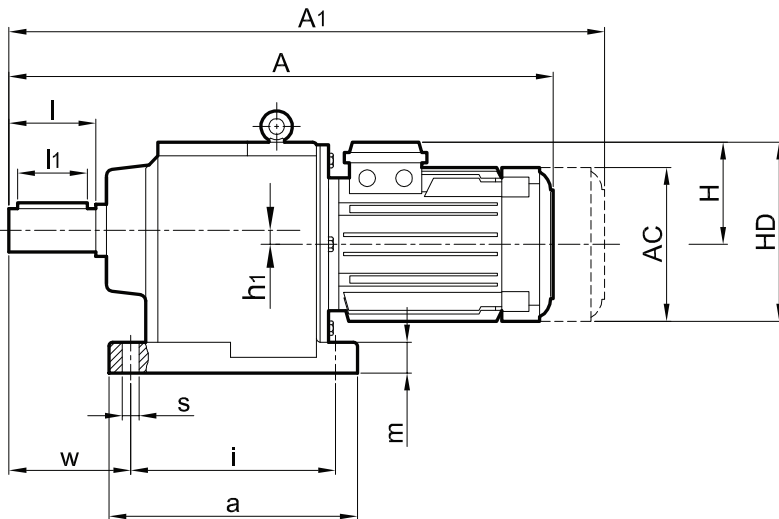

Type Type	Torque (Max) Couple (Max)	Shaft Diameter Diamètre de l'arbre de sortie
IRA 42-43	90 Nm	Ø 20
IRA 52-53	190 Nm	Ø 25
IRA 621-631-641	300 Nm	Ø 30
IRA 62-63-64	400 Nm	Ø 35
IRA 721-731-741	600 Nm	Ø 35
IRA 72-73-74	850 Nm	Ø 40
IRA 82-83-84	1440 Nm	Ø 50
IRA 92-93-94	3000 Nm	Ø 60
IRA 102-103-104	4300 Nm	Ø 70
IRA 122-123-124	8000 Nm	Ø 90
IRA 142-143-144	13000 Nm	Ø 110
IRA 152-153-154	18000 Nm	Ø 120

**Output Shaft Applications / Spécificités de l'arbre de sortie**

IRA Type Gearboxes have solid shaft output.  
 Les motoréducteurs du type IRA dispose d'arbre de sortie solides.

**Speed Range / Vitesse**

2,4 d/d ... 852 d/d

**Applicable Motor Power / Puissance moteur applicable**

0,12 kW ... 55 kW

**Mounting Positions / Position de montage**

You can choose from Foot and Flange mounting options according to your need.  
 Disponible monté sur pied ou pendulaire, en fonction de vos besoins.

**Input Options / Options d'entrée**

Helical gear units [IRA] Réducteurs sans moteur  
 Helical gear units [IRAP](IEC) Réducteurs avec adaptateur normalisé sans moteur  
 Helical geared motors [IRAM] Réducteurs avec moteur  
 Helical geared motors [IRAPM](IEC) Réducteurs avec adaptateur normalisé et moteur

**Brake Types / Types de freins**

24V DC or 220v AC electromagnetic brakes.  
 Freins électromagnétiques 24V DC ou 220V AC.



Typ	Motor	A	A1	H	HD	AC	x	Ød	l	l1	t	u	M	h	h1	h2	Øs	w	i	i1	a	a1	m	b	e
IRAM 42 / 43	63 M	352	406	108	171	125	-	20	40	32	22,5	6	M6	75	3,9	132	9	70	110	110	130	135	13	144	-
	71 M	396	450	123	194	139	-																		
	80 M	469	530	136	216	158	7,9																		
	90 S	462	529	141	231	176	16,9																		
	90 L	526	593	141	231	176	16,9																		
IRAM 52 / 53	63 M	431	485	108	171	125	-	25	50	40	28	8	M10	90	4,97	160	9	74	130	110	160	149	16	176	5,68
	71 M	427	481	123	194	139	-																		
	80 M	497	558	136	216	158	-																		
	90 S	489	556	141	231	176	3																		
	90 L	553	620	141	231	176	3																		
	100 L	593	670	161	261	195	12,5																		
IRAM 621 / 631	63 M	473	527	108	171	125	-	30	60	50	33	8	M10	115	11,3	186	13	88	165	135	200	185	25	200	-
	71 M	462	516	123	194	139	-																		
	80 M	535	596	136	216	158	-																		
	90 S	528	595	141	231	176	-																		
	90 L	592	659	141	231	176	-																		
	100 L	631	708	161	261	195	-																		
	112 M	602	697	170	282	220	6,3																		
	132 S	658	762	193	325	262	27,3																		
IRAM 62 / 63	63 M	483	537	108	171	125	-	35	70	56	38	10	M12	115	11,3	186	13	98	165	135	200	185	25	200	-
	71 M	472	526	123	194	139	-																		
	80 M	545	606	136	216	158	-																		
	90 S	538	605	141	231	176	-																		
	90 L	602	669	141	231	176	-																		
	100 L	641	718	161	261	195	-																		
	112 M	612	707	170	282	220	6,3																		
	132 S	668	772	193	325	262	27,3																		
IRAM 721 / 731	71 M	487	541	123	194	139	-	35	70	56	38	10	M12	130	6,8	213	14	100	195	150	235	210	28	225	-
	80 M	560	621	136	216	158	-																		
	90 S	554	621	141	231	176	-																		
	90 L	618	685	141	231	176	-																		
	100 L	659	736	161	261	195	-																		
	112 M	634	729	170	282	220	-																		
	132 S	690	794	193	325	262	7,8																		
	132 M	735	839	193	325	262	7,8																		
IRAM 72 / 73	71 M	516	570	123	194	139	-	40	80	70	43	12	M16	140	15,9	228	16	115	205	170	245	230	30	248	-
	80 M	589	650	136	216	158	-																		
	90 S	582	649	141	231	176	-																		
	90 L	646	713	141	231	176	-																		
	100 L	687	764	161	261	195	-																		
	112 M	662	757	170	282	220	-																		
	132 S	733	837	193	325	262	6,9																		
	132 M	778	882	193	325	262	6,9																		
	160 M	861	978	240	400	315	33,4																		



Typ	Motor	A	A1	H	HD	AC	x	Ød	l	l1	t	u	M	h	h1	h2	Øs	w	i	i1	a	a1	m	b	e
IRAM 82 / 83	80 M	658	719	136	216	158	-	50	100	85	53,5	14	M16	180	23,6	290	17	139	260	215	310	290	40	310	-
	90 S	649	716	141	231	176	-																		
	90 L	713	780	141	231	176	-																		
	100 L	753	830	161	261	195	-																		
	112 M	727	822	170	282	220	-																		
	132 S	797	901	193	325	262	-																		
	132 M	842	946	193	325	262	-																		
	160 M	950	1067	240	400	315	1																		
	160 L	995	1112	240	400	315	1																		
	180 M	1007	1143	260	440	357	22																		
	180 L	1044	1180	260	440	357	22																		
IRAM 92 / 93	80 M	794	855	136	216	158	-	60	120	100	64	18	M20	225	21,4	355	22	160	310	250	368	340	45	365	-
	90 S	803	870	141	231	176	-																		
	90 L	841	908	141	231	176	-																		
	100 L	813	890	161	261	195	-																		
	112 M	787	882	170	282	220	-																		
	132 S	849	953	193	325	262	-																		
	132 M	894	998	193	325	262	-																		
	160 M	989	1106	240	400	315	-																		
	160 L	1034	1151	240	400	315	-																		
	180 M	1046	1182	260	440	357	-																		
	180 L	1083	1219	260	440	357	-																		
	200 L	1168	1315	300	500	394	-																		
	IRAM 102 / 103	100 L	897	974	161	261	195																		
112 M		868	963	170	282	220	-																		
132 S		918	1022	193	325	262	-																		
132 M		963	1067	193	325	262	-																		
160 M		1041	1158	240	400	315	-																		
160 L		1086	1203	240	400	315	-																		
180 M		1113	1249	260	440	357	-																		
180 L		1150	1286	260	440	357	-																		
200 L		1248	1395	300	500	394	-																		
225 S		1207	1354	313	538	456	-																		
225 M		1300	1447	313	538	456	-																		
IRAM 122 / 123		132 S	978	1082	193	325	262	-	90	170	150	95	25	M24	315	24,7	505	33	220	410	340	490	474	70	515
	132 M	1023	1127	193	325	262	-																		
	160 M	1109	1226	240	400	315	-																		
	160 L	1154	1271	240	400	315	-																		
	180 M	1168	1304	260	440	357	-																		
	180 L	1205	1341	260	440	357	-																		
	200 L	1300	1447	300	500	394	-																		
	225 S	1258	1405	313	538	456	-																		
	225 M	1351	1498	313	538	456	-																		
	250 M	1364	1511	366	616	489	-																		



Typ	Motor	A	A1	H	HD	AC	x	Ød	l	l1	t	u	M	h	h1	h2	Øs	w	i	i1	a	a1	m	b	e
IRAM 142 / 143	132 M	1237	1341	193	325	262	-	110	210	180	116	28	M24	355	27	570	38	260	500	380	590	550	80	595	-
	160 M	1235	1352	240	400	315	-																		
	160 L	1280	1397	240	400	315	-																		
	180 M	1295	1431	260	440	357	-																		
	180 L	1332	1468	260	440	357	-																		
	200 L	1427	1574	300	500	394	-																		
	225 S	1385	1532	313	538	456	-																		
	225 M	1478	1625	313	538	456	-																		
	250 M	1491	1638	366	616	489	-																		
	280 S	1552	1800	398	678	548	-																		
	280 M	1552	1800	398	678	548	-																		
IRAM 152 / 153	160 M	1295	1412	240	400	315	-	120	210	180	127	32	M24	425	46.5	675	39	270	580	500	670	660	100	710	-
	160 L	1340	1457	240	400	315	-																		
	180 M	1352	1488	260	440	357	-																		
	180 L	1389	1525	260	440	357	-																		
	200 L	1484	1631	300	500	394	-																		
	225 S	1442	1589	313	538	456	-																		
	225 M	1535	1682	313	538	456	-																		
	250 M	1548	1695	366	616	489	-																		
	280 S	1609	1857	398	678	548	-																		
	280 M	1609	1857	398	678	548	-																		
	315 S	1814	2062	518	833	652	-																		
	315 M	1814	2072	518	833	652	-																		

Available in one or two stage of gears, the IR Series gearboxes provide optimal solutions for a large range of application. The unicast housing of the gearbox and the gears technology is offering a perfect balance between power and space optimization.

*Disponibles dans une large gamme de dimensions et de rapports de réduction, les motoréducteurs de la série IR sont utilisables dans de nombreuses situations. Particulièrement adaptés aux applications avec de fortes charges radiales, les motoréducteurs de la série IR sont disponibles dans des dimensions allant de 42 à 153 cm, assurant ainsi leur grande polyvalence.*

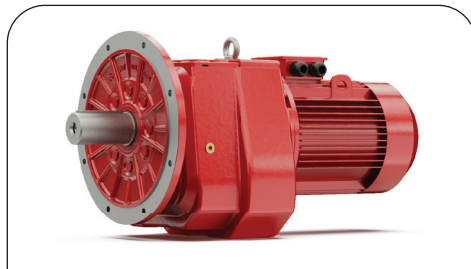
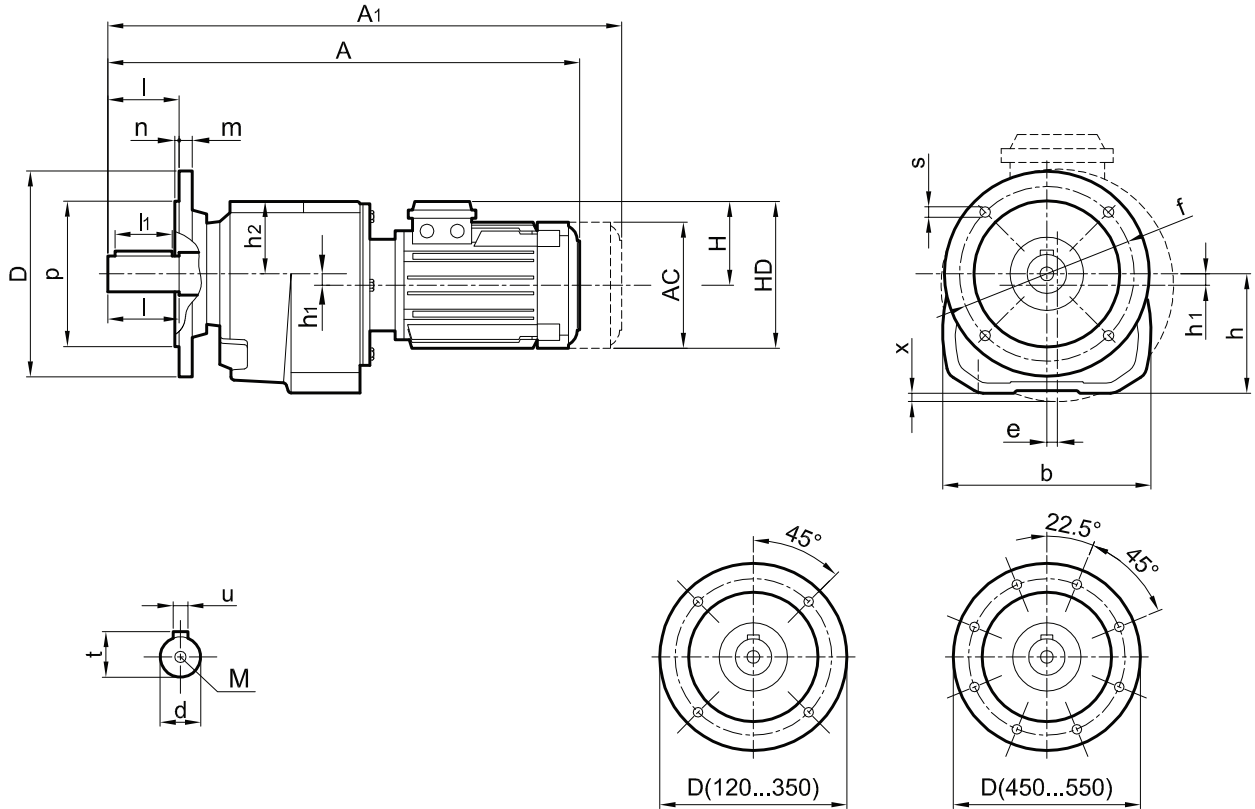

Type <i>Type</i>	Torque (Max) <i>Couple (Max)</i>	Shaft Diameter <i>Diamètre de l'arbre de sortie</i>
IRF 42-43	90 Nm	Ø 20
IRF 52-53	190 Nm	Ø 25
IRF 621-631-641	300 Nm	Ø 30
IRF 62-63-64	400 Nm	Ø 35
IRF 721-731-741	600 Nm	Ø 35
IRF 72-73-74	850 Nm	Ø 40
IRF 82-83-84	1440 Nm	Ø 50
IRF 92-93-94	3000 Nm	Ø 60
IRF 102-103-104	4300 Nm	Ø 70
IRF 122-123-124	8000 Nm	Ø 90
IRF 142-143-144	13000 Nm	Ø 110
IRF 152-153-154	18000 Nm	Ø 120

**Output Shaft Applications / Spécificités de l'arbre de sortie**

IRF Type Gearboxes have solid shaft output.  
*Les motoréducteurs du type IRF dispose d'arbre de sortie solides.*

**Speed Range / Vitesse**

2,4 d/d ... 852 d/d

**Applicable Motor Power / Puissance moteur applicable**

0,12 kW ... 55 kW

**Mounting Positions / Position de montage**

You can choose from Foot and Flange mounting options according to your need.  
*Disponible monté sur pied ou pendulaire, en fonction de vos besoins.*

**Input Options / Options d'entrée**

Helical gear units [IRF] Réducteurs sans moteur  
Helical gear units [IRAP](IEC) Réducteurs avec adaptateur normalisé sans moteur  
*Helical geared motors [IRFM] Réducteurs avec moteur*  
*Helical geared motors [IRFPM](IEC) Réducteurs avec adaptateur normalisé et moteur*

**Brake Types / Types de freins**

24V DC or 220v AC electromagnetic brakes.  
*Freins électromagnétiques 24V DC ou 220V AC.*



Typ	Motor	A	A1	H	HD	AC	x	Ød	l	l1	t	u	M	Øp	Øf	ØD	Øs	m	n	h	h1	h2	b	e
IRFM 42 / 43	63 M	352	406	108	171	125	-	20	40	32	22,5	6	M6	80 95 110	100 115 130	120 140 160	6,5 8,5 8,5	8 9 10	3 3 3,5	77	3,9	57	144	-
	71 M	396	450	123	194	138,5	-																	
	80 M	469	530	136	216	158	7,9																	
	90 S	462	529	141	231	176	16,9																	
	90 L	526	593	141	231	176	16,9																	
IRFM 52 / 53	63 M	431	485	108	171	125	-	25	50	40	28	8	M10	95 110	115 130	140 160	9	10	3,5	92	4,97	70	176	5,68
	71 M	427	481	123	194	138,5	-																	
	80 M	497	558	136	216	158	-																	
	90 S	489	556	141	231	176	3																	
	90 L	553	620	141	231	176	3																	
	100 L	593	670	161	261	195	12,5																	
IRFM 621 / 631	63 M	473	527	108	171	125	-	30	60	50	33	8	M10	110 130 180	130 165 215	160 200 250	9 11 14	12 12 14	3,5 3,5 4	117	11,3	71	200	-
	71 M	462	516	123	194	138,5	-																	
	80 M	535	596	136	216	158	-																	
	90 S	528	595	141	231	176	-																	
	90 L	592	659	141	231	176	-																	
	100 L	631	708	161	261	195	-																	
	112 M	602	697	170	282	220	6,3																	
	132 S	658	762	193	325	262	27,3																	
IRFM 62 / 63	63 M	483	537	108	171	125	-	35	70	56	38	10	M12	110 130 180	130 165 215	160 200 250	9 11 14	12 12 14	3,5 3,5 4	117	11,3	71	200	-
	71 M	472	526	123	194	138,5	-																	
	80 M	545	606	136	216	158	-																	
	90 S	538	605	141	231	176	-																	
	90 L	602	669	141	231	176	-																	
	100 L	641	718	161	261	195	-																	
	112 M	612	707	170	282	220	6,3																	
	132 S	668	772	193	325	262	27,3																	
IRFM 721 / 731	71 M	487	541	123	194	138,5	-	35	70	56	38	10	M12	130 180	165 215	200 250	11 14	12 14	3,5 4	133	6,8	83	225	-
	80 M	560	621	136	216	158	-																	
	90 S	554	621	141	231	176	-																	
	90 L	618	685	141	231	176	-																	
	100 L	659	736	161	261	195	-																	
	112 M	634	729	170	282	220	-																	
	132 S	690	794	193	325	262	7,8																	
	132 M	735	839	193	325	262	7,8																	
IRFM 72 / 73	71 M	516	570	123	194	138,5	-	40	80	70	43	12	M16	180 230	215 265	250 300	14	14 16	4	143	15,9	88	248	-
	80 M	589	650	136	216	158	-																	
	90 S	582	649	141	231	176	-																	
	90 L	646	713	141	231	176	-																	
	100 L	687	764	161	261	195	-																	
	112 M	662	757	170	282	220	-																	
	132 S	733	837	193	325	262	6,9																	
	132 M	778	882	193	325	262	6,9																	
	160 M	861	978	240	400	315	33,4																	

Typ	Motor	A	A1	H	HD	AC	x	Ød	l	l1	t	u	M	Øp	Øf	ØD	Øs	m	n	h	h1	h2	b	e	
IRFM 82 / 83	80 M	658	719	136	216	158	-	50	100	85	53,5	14	M16	180	215	250	14	16	4	183	23,6	110	310	-	
	90 S	649	716	141	231	176	-																		
	90 L	713	780	141	231	176	-																		
	100 L	753	830	161	261	195	-																		
	112 M	726,5	821,5	170	282	220	-																		
	132 S	797	901	193	325	262	-																		
	132 M	842	946	193	325	262	-																		
	160 M	950	1067	240	400	315	1																		
	160 L	995	1112	240	400	315	1																		
	180 M	1007	1143	260	440	357	22																		
	200 L	1044	1180	260	440	357	22																		
IRFM 92 / 93	80 M	794	855	136	216	158	-	60	120	100	64	18	M20	250	300	350	17,5	18	22	5	225	21,4	130	365	-
	90 S	803	870	141	231	176	-																		
	90 L	841	908	141	231	176	-																		
	100 L	813	890	161	261	195	-																		
	112 M	787	882	170	282	220	-																		
	132 S	849	953	193	325	262	-																		
	132 M	894	998	193	325	262	-																		
	160 M	989	1106	240	400	315	-																		
	160 L	1034	1151	240	400	315	-																		
	180 M	1046	1182	260	440	357	-																		
	180 L	1083	1219	260	440	357	-																		
	200 L	1168	1315	300	500	394	-																		
IRFM 102 / 103	100 L	897	974	161	261	195	-	70	130	115	74,5	20	M20	250	300	350	17,5	20	22	5	250	21,3	158	420	-
	112 M	868	963	170	282	220	-																		
	132 S	918	1022	193	325	262	-																		
	132 M	963	1067	193	325	262	-																		
	160 M	1041	1158	240	400	315	-																		
	160 L	1086	1203	240	400	315	-																		
	180 M	1113	1249	260	440	357	-																		
	180 L	1150	1286	260	440	357	-																		
	200 L	1248	1395	300	500	394	-																		
	225 S	1207	1354	313	538	456	-																		
	225 M	1300	1447	313	538	456	-																		
	IRFM 122 / 123	132 S	978	1082	193	325	262																		
132 M		1023	1127	193	325	262	-																		
160 M		1109	1226	240	400	315	-																		
160 L		1154	1271	240	400	315	-																		
180 M		1168	1304	260	440	357	-																		
180 L		1205	1341	260	440	357	-																		
200 L		1300	1447	300	500	394	-																		
225 S		1258	1405	313	538	456	-																		
225 M		1351	1498	313	538	456	-																		
250 M		1364	1511	366	616	489	-																		



Typ	Motor	A	A1	H	HD	AC	x	Ød	l	l1	t	u	M	Øp	Øf	ØD	Øs	m	n	h	h1	h2	b	e
IRFM 142 / 143	132 M	1237	1341	193	325	262	-	110	210	180	116	28	M24	450	500	550	18	25	5	355	27,0	215	595	-
	160 M	1235	1352	240	400	315	-																	
	160 L	1280	1397	240	400	315	-																	
	180 M	1295	1431	260	440	357	-																	
	180 L	1332	1468	260	440	357	-																	
	200 L	1427	1574	300	500	394	-																	
	225 S	1385	1532	313	538	456	-																	
	225 M	1478	1625	313	538	456	-																	
	250 M	1491	1638	366	616	489	-																	
	280 S	1552	1800	398	678	547,5	-																	
	280 M	1552	1800	398	678	547,5	-																	
IRFM 152 / 153	160 M	1295	1412	240	400	315	-	120	210	180	127	32	M24	550	600	660	22	30	6	425	45,5	250	710	-
	160 L	1340	1457	240	400	315	-																	
	180 M	1352	1488	260	440	357	-																	
	180 L	1389	1525	260	440	357	-																	
	200 L	1484	1631	300	500	394	-																	
	225 S	1442	1589	313	538	456	-																	
	225 M	1535	1682	313	538	456	-																	
	250 M	1548	1695	366	616	489	-																	
	280 S	1609	1857	398	678	547,5	-																	
	280 M	1609	1857	398	678	547,5	-																	
	315 S	1814	2062	518	833	652	-																	
	315 M	1814	2072	518	833	652	-																	

The shaft mounted gear series ( IRO ) are the best solutions for quarries and mining sectors. The backstop feature of the gearboxes allow you to load heavy charges on your inclined conveyors or applications. The IRO series also assist you with low maintenance and high reliability.

Les séries d'engrenages montés sur arbre (IRO) sont les meilleures solutions pour les carrières et les secteurs miniers. La fonction anti-retour des boîtes de vitesses vous permet de charger de lourdes charges sur vos convoyeurs ou applications inclinés. La série IRO vous assiste également avec un faible entretien et une grande fiabilité.

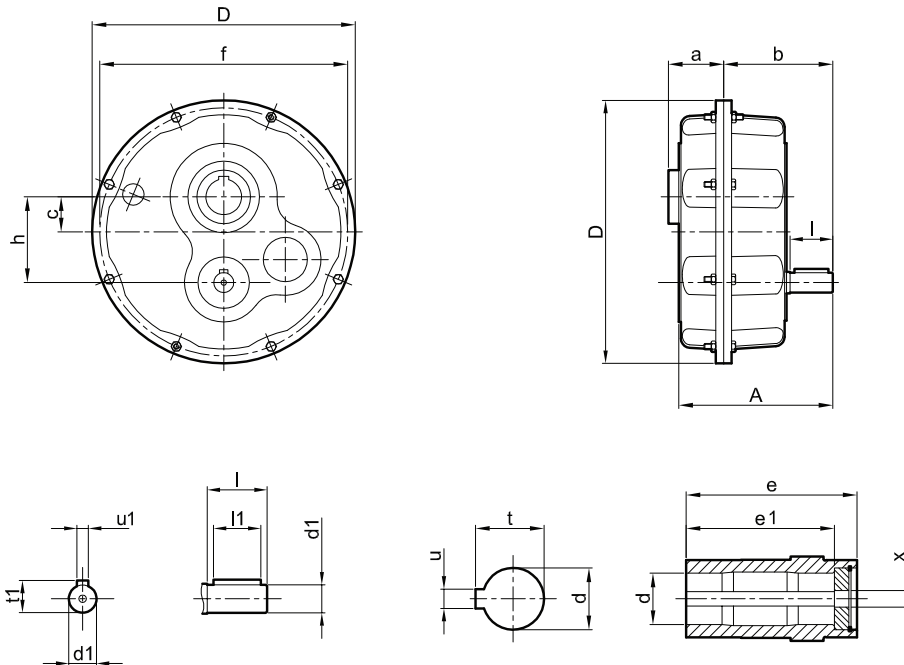

TYPE	A	D	Ød1	l	l1	t1	u1	Ød	e	e1	t	u	x	h	f	a	b	c
<b>IRO 41</b>	190	330	24	50	40	27	8	45	147	129	48,8	14	17	111	310	64	137	38,5
<b>IRO 51</b>	215	368	28	60	50	31	8	50	166	144	53,8	14	17	120	347	77	152	49
<b>IRO 61</b>	258	438	38	80	70	41	10	60	182	160	64,4	18	17	140	415	79	190	59
<b>IRO 71</b>	320	525	42	110	100	45	12	70	218	192,5	74,9	20	17	180	500	92	240	67
<b>IRO 81</b>	352	600	48	110	100	51,5	14	100	262	226	106,4	28	26	203	570	114	259	75



Type Type	Torque (Max) Couple (Max)	Hollow Shaft Diameter Diamètre de l'arbre creux
IRO 41	930 Nm	Ø 45
IRO 51	1400 Nm	Ø 50
IRO 61	2700 Nm	Ø 60
IRO 71	5000 Nm	Ø 70
IRO 81	7530 Nm	Ø 100

**Output Shaft Applications / Spécificités de l'arbre de sortie**

IRO type gearboxes can be used as hollow shaft connected.

Les réducteurs pendulaires (IRO) peuvent être utilisés avec un arbre de sortie creux.

**Speed Range / Vitesse**

46 d/d ... 280 d/d

**Applicable Motor Power / Puissance moteur applicable**

2,2 kW ... 160 kW

**Options / Options**

IRO gearboxes are available with backstop

Les réducteurs IRO sont disponibles avec une option roulement anti-retour.

The shaft mounted gear series ( IRO ) are the best solutions for quarries and mining sectors. The backstop feature of the gearboxes allow you to load heavy charges on your inclined conveyors or applications. The IRO series also assist you with low maintenance and high reliability.

Les séries d'engrenages montés sur arbre (IRO) sont les meilleures solutions pour les carrières et les secteurs miniers. La fonction anti-retour des boîtes de vitesses vous permet de charger de lourdes charges sur vos convoyeurs ou applications inclinés. La série IRO vous assiste également avec un faible entretien et une grande fiabilité.

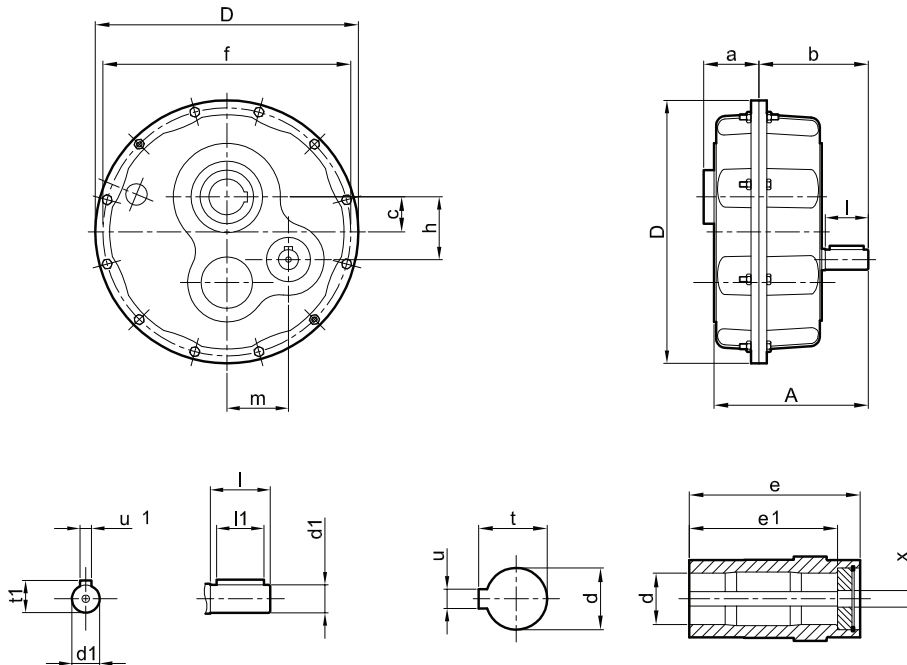

TYPE	A	D	Ød1	l	l1	t1	u1	Ød	e	e1	t	u	x	h	m	f	a	b	c
<b>IRO 42</b>	190	330	24	50	40	27	8	45	147		48,8	14	17	91	79,6	310	64	137	38,5
<b>IRO 52</b>	215	368	28	60	50	31	8	50	166	144	53,8	14	17	88	86	347	77	152	49
<b>IRO 62</b>	258	438	38	80	70	41	10	60	182		64,4	18	17	94	108	415	79	190	59
<b>IRO 72</b>	320	525	42	110	100	45	12	70	218		74,9	20	17	143	125	500	92	240	67
<b>IRO 82</b>	352	600	48	110	100	51,5	14	100	262		106,4	28	26	181	145	570	114	259	75

**Output Shaft Applications / Spécificités de l'arbre de sortie**

IRO type gearboxes can be used as hollow shaft connected.

Les réducteurs pendulaires (IRO) peuvent être utilisés avec un arbre de sortie creux.

**Speed Range / Vitesse**

46 d/d ... 280 d/d

**Applicable Motor Power / Puissance moteur applicable**

2,2 kW ... 160 kW

**Options / Options**

IRO gearboxes are available with backstop

Les réducteurs IRO sont disponibles avec une option roulement anti-retour.



Type Type	Torque (Max) Couple (Max)	Hollow Shaft Diameter Diamètre de l'arbre creux
IRO 42	930 Nm	Ø 45
IRO 52	1400 Nm	Ø 50
IRO 62	2700 Nm	Ø 60
IRO 72	5000 Nm	Ø 70
IRO 82	7530 Nm	Ø 100



Specially designed for the harsh and hard environment of today's industry, the IRNX Series are the best solutions for bulk material transportation, mining and cements industries.

The shaft mounted feature allows you to directly mount the gearboxes to many different applications. The quick and easy mounting and high versatility of the IRNX Series also allow quick and fast action to limit costly downtimes.

*Spécialement conçues pour les environnements difficiles et difficiles de l'industrie d'aujourd'hui, la série IRNX est la meilleure solution pour les industries du transport de matériaux en vrac, des mines et des ciments.*

*La fonction de montage sur arbre vous permet de monter directement les boîtes de vitesses dans de nombreuses applications différentes. Le montage rapide et facile et la grande polyvalence de la série IRNX permettent également une action rapide et rapide pour limiter les temps d'arrêt coûteux.*

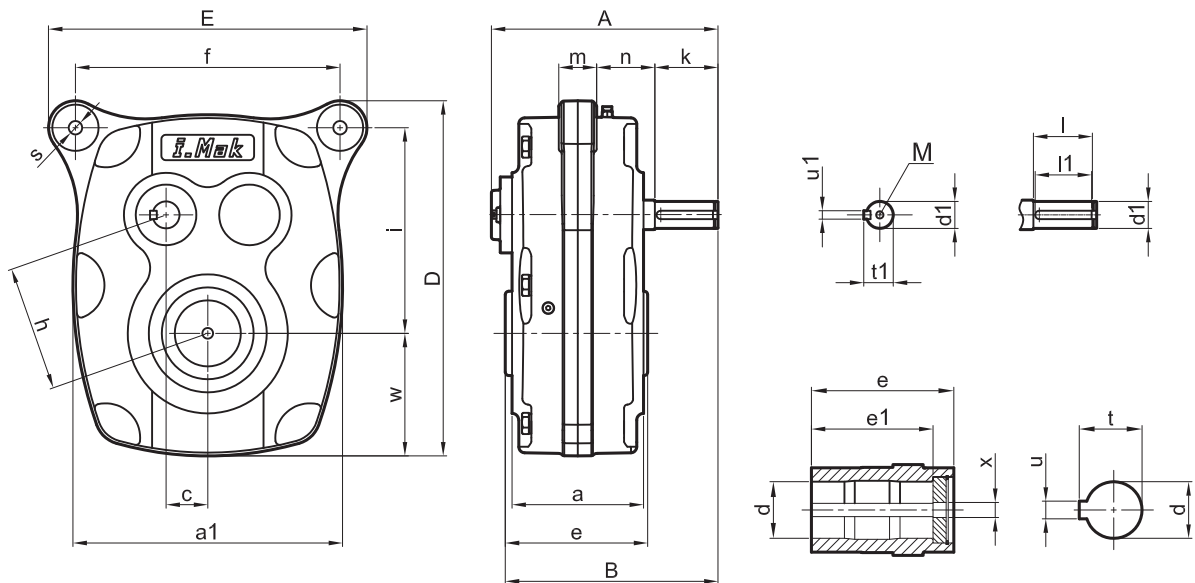

Type Type	Torque (Max) Couple (Max)	Shaft Diameter Diamètre de l'arbre de sortie
IRNX 01	510 Nm	Ø 30
IRNX 02	810 Nm	Ø 40
IRNX 03	1270 Nm	Ø 50
IRNX 04	1810 Nm	Ø 50
IRNX 05	3160 Nm	Ø 60
IRNX 06	4690 Nm	Ø 70
IRNX 07	7400 Nm	Ø 85
IRNX 08	9810 Nm	Ø 100
IRNX 09	12420 Nm	Ø 120
IRNX 10	17900 Nm	Ø 125
IRNX 11	24460 Nm	Ø 150
IRNX 12	42700 Nm	Ø 190

**Output Shaft Applications / Spécificités de l'arbre de sortie**

IRNX type gearboxes can be used as hollow shaft connected.

*Les réducteurs pendulaires (IRNX) peuvent être utilisés avec un arbre de sortie creux.*

**Range of Ratios / Rapports de réduction**

46 d/d ... 280 d/d

**Applicable Motor Power / Puissance moteur applicable**

1/10 kW ... 1/30 kW

**Options / Options**

IRO gearboxes are available with backstop

*Les réducteurs IRO sont disponibles avec une option roulement anti-retour.*



Tip Typ	A	B	D	E	Ød1	l	l1	t1	u1	M	Ød	e	e1	t	u	x	h	f	i	Øs	m	n	k	a	a1	c	w
İRNX 01	168	173	247,5	194	19	40	35	21,5	6	M6	30	114	100	33,3	8	M10	80	160	145	8	29	57,5	44	104	185	28	85,5
İRNX 02	206	188	270	227	22	45	40	24,5	6	M6	40	122	107	43,3	12	M12	95	195	156	10	29	62,5	49	112	210	31	98
İRNX 03	221,5	204,5	318,5	253	25	55	52	28	8	M8	50	132	115	53,8	14	M16	117	219	186,5	10	29	63,5	59	121	250	37,5	115
İRNX 04	243,5	227	390	292	28	60	52	31	8	M8	50	150	133	53,8	14	M16	132	242	238	12	34	69	64	138	278	43,5	127
İRNX 05	268,5	252	421,5	378	32	70	67	35	10	M10	60	169	150	64,4	18	Ø17	149	314	244	16	45	68,5	75	156	320	49,5	145,5
İRNX 06	309,5	288,5	497,5	420	42	90	85	45	12		70	192	172	74,9	20	Ø22	166	356	277	16	49	71	96	180	360	56	170,5
İRNX 07	340,5	322,5	592,5	354	48	100	95	51,5	14	M12	85	222	199	90,4	22	Ø22	201	290	355	16	49	81	105,5	202	445	62	205,5
İRNX 08	376	359	751,5	382	55	128	115	59	16	M20	100	237	213	106,4	28	Ø26	265	314	456	16	49	83,5	128	206	546	76,5	263
İRNX 09	466	458	820	380	60	168	150	64	18	M20	120	306	271	127,4	32	Ø26	282	320	518	22	49	113	168	247	585	87	270
İRNX 10	476,5	463,5	900	470	60	168	150	64	18	M20	125	310	278	132,4	32	Ø26	297	382	557	22	600	108,5	168	230	642	100	301
İRNX 11	568	538	1165	650	65	190	175	69	18	M20	150	357	322	158,4	36	Ø33	345	450	700	31	100	110	199	266	772	119	365
İRNX 12	650	604	1285	725	85	200	190	90	22	M20	190	406	371	200,4	45	Ø33	396	500	750	31	100	141	210	318	885	133	420

The parallel helical shaft gear units YP series remain the optimal solution for complex and space limited applications. The fully reversible design of the gearbox offers a large range of mounting positions. The gears combinations allow high loads and the options for low output speed makes it the ideal solution for a very large range of applications.

*Les réducteurs à arbres parallèles de la série YP restent la solution optimale pour les applications complexes et peu encombrantes. La conception entièrement réversible de la boîte de vitesses offre une large gamme de positions de montage. Les combinaisons d'engrenages permettent des charges élevées et les options de faible vitesse de sortie en font la solution idéale pour une très large gamme d'applications.*

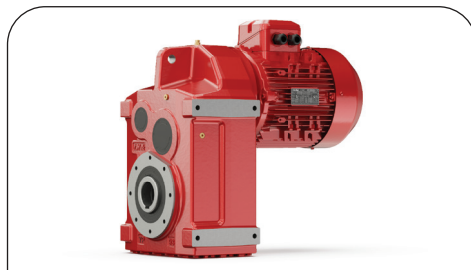
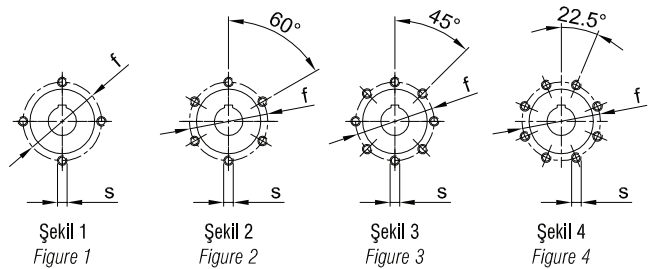
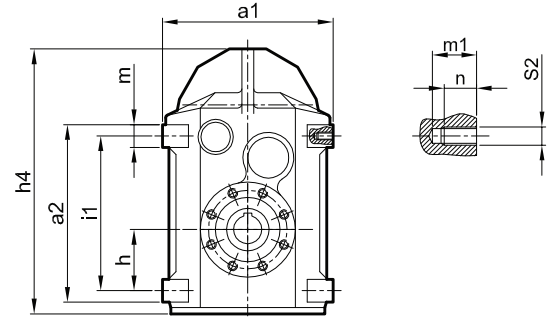
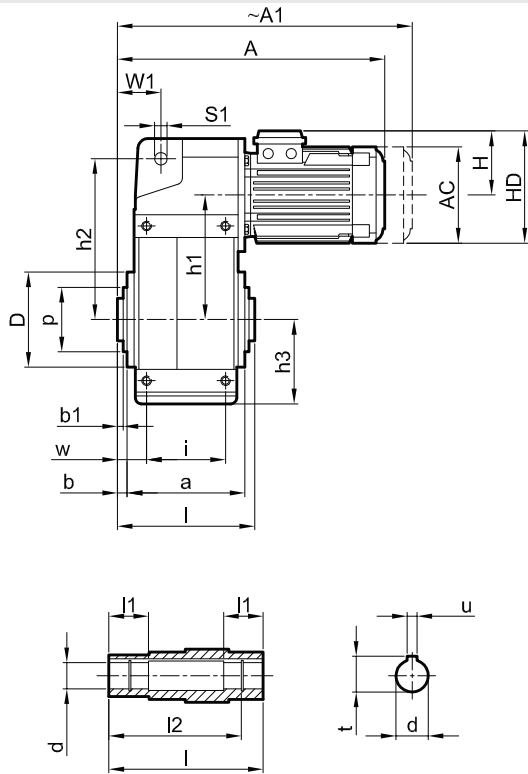

Type Type	Torque (Max) Couple (Max)	Shaft Diameter Diamètre de l'arbre de sortie
YP 42-43	130 Nm	Ø 25
YP 52-53	200 Nm	Ø 30
YP 62-63	400 Nm	Ø 35
YP 72-73-74	820 Nm	Ø 40
YP 82-83-84	1500 Nm	Ø 50
YP 92-93-94	3000 Nm	Ø 60
YP 102-103-104	4300 Nm	Ø 70
YP 122-123-124	7800 Nm	Ø 90
YP 142-143-144	13000 Nm	Ø 110
YP 152-153-154	18000 Nm	Ø 120

**Output Shaft Applications / Spécificités de l'arbre de sortie**

YP Type Gearboxes have solid shaft Output.  
*Les motoréducteurs du type YP dispose d'arbre de sorties pleins ou creux.*

**Speed Range / Vitesse**

2,4 d/d ... 391 d/d

**Applicable Motor Power / Puissance moteur applicable**

0,12 kW ... 200 kW

**Mounting Positions / Position de montage**

You can choose from foot and flange mounting options according to your need.  
*Disponible monté sur pied ou libre, en fonction de vos besoins.*

**Input Options / Options d'entrée**

Helical gear units [YP] Réducteurs sans moteur  
 Helical gear units [YPP](IEC) Réducteurs avec adaptateur normalisé sans moteur  
 Helical geared motors [YPM] Réducteurs avec moteur  
 Helical geared motors [YPPM](IEC) Réducteurs avec adaptateur normalisé et moteur

**Brake Types / Types de freins**

24V DC or 220v AC electromagnetic brakes.  
*Freins électromagnétiques 24V DC ou 220V AC.*



Type	Motor	A	A1	H	HD	AC	Ød	l	t	u	l1	l2	w1	h	h1	h2	h3	h4	a	a1	a2	Øs1	w	i	Øp	Øf	ØD	s	Figure	m	i1	s2	m1	n	b	b1		
YPM 42/43	63 M	328,5	382,5	108	171	125																																
	71 M	324,5	378,5	123	194	138,5																																
	80 M	396	457	136	216	158	25	106	28,3	8	36	90	45	31	102	140	73	225	97,5	150	120	14	21	65	74	86	-	M8	1	20	100	M8	14	10	4,5	-		
	90 S	387	454	141	231	176																																
	90 L	451	518	141	231	176																																
YPM 52/53	63 M	342,5	396,5	108	171	125																																
	71 M	338,5	392,5	123	194	138,5																																
	80 M	410	471	136	216	158	30	118	33,3	8	39	102	55,5	31	115	158	79	264	109,5	172	139	14	22,5	77	85	94	-	M8	2	24	115	M8	17	14	5,5	-		
	90 S	401	468	141	231	176																																
	90 L	465	532	141	231	176																																
	100 L	505	582	161	261	195																																
YPM 62/63	63 M	369,5	423,5	108	171	125																																
	71 M	358,5	412,5	123	194	138,5																																
	80 M	431	492	136	216	158																																
	90 S	424	491	141	231	176	35	150	38,3	10	50	130	57	43	131	170	88	300	142,5	195	171	14	31	93	124	102	-	M8	1	26	145	M10	19	16	4	-		
	90 L	488	555	141	231	176																																
	100 L	527	604	161	261	195																																
	112 M	498,5	593,5	170	282	220																																
YPM 72/73	63 M	393,5	447,5	108	171	125																																
	71 M	382,5	436,5	123	194	138,5																																
	80 M	455	516	136	216	158																																
	90 S	448	515	141	231	176																																
	90 L	512	579	141	231	176	40	180	43,3	12	60	155	76	60	159	218	110	349	170	234	218	14	37,5	112	140	115	-	M8	2	28	190	M10	20	26	5	-		
	100 L	551	628	161	261	195																																
	112 M	522,5	617,5	170	282	220																																
	132 S	578	682	193	325	262																																
	132 M	623	727	193	325	262																																
YPM 82/83	71 M	404,5	458,5	123	194	138,5																																
	80 M	477,5	538,5	136	216	158																																
	90 S	470,5	537,5	141	231	176																																
	90 L	534,5	601,5	141	231	176																																
	100 L	576,5	653,5	161	261	195	50	210	53,8	14	70	180	97	70	196	260	129	425	200,5	270	275	22	37	140	174	143	-	M10	3	35	240	M12	25	20	5	-		
	112 M	551	646	170	282	220																																
	132 S	607	711	193	325	262																																
132 M	652	756	193	325	262																																	

Type	Motor	A	A1	H	HD	AC	Ød	l	t	u	l1	l2	w1	h	h1	h2	h3	h4	a	a1	a2	Øs1	w	i	Øp	Øf	ØD	s	Figure	m	i1	s2	m1	n	b	b1			
YPM 92 / 93	80 M	500	561	136	216	158																																	
	90 S	490	557	141	231	176																																	
	90 L	554	621	141	231	176																																	
	100 L	595	672	161	261	195																																	
	112 M	568,5	663,5	170	282	220																																	
	132 S	636	740	193	325	262	60	243	64,4	18	80	212	105	100	241	331	149	515	230	325	350	22	39	165	210	180	-	M12	3	40	310	M14	33	28	8	-			
	132 M	681	785	193	325	262																																	
	160 M	754	871	240	400	315																																	
	160 L	799	916	240	400	315																																	
	180 M	808,5	944,5	260	440	357																																	
180 L	845,5	981,5	260	440	357																																		
YPM 102 / 103	90 S	627	694	141	231	176																																	
	90 L	665	732	141	231	176																																	
	100 L	637,5	714,5	161	261	195																																	
	112 M	611	706	170	282	220																																	
	132 S	672,5	776,5	193	325	262																																	
	132 M	717,5	821,5	193	325	262	70	310	74,9	20	103	279	111	120	294	395	178	622	287	403	400	26	53	205	180	215	250	M14	4	50	350	M16	35	30	12	8			
	160 M	813	930	240	400	315																																	
	160 L	858	975	240	400	315																																	
180 M	876	1012	260	440	357																																		
180 L	913	1049	260	440	357																																		
200 L	991,5	1138,5	300	500	394																																		
YPM 122 / 123	100 L	677	754	161	261	195																																	
	112 M	642,5	737,5	170	282	220																																	
	132 S	710	814	193	325	262																																	
	132 M	755	859	193	325	262																																	
	160 M	832	949	240	400	315																																	
	160 L	877	994	240	400	315	90	360	95,4	25	121	320	154	125	333	460	204	712	324	470	460	26	69,5	220	-	-	300	-	-	60	400	M24	42	34	18	7,5			
	180 M	904,5	1040,5	260	440	357																																	
	180 L	941,5	1077,5	260	440	357																																	
200 L	1039,5	1186,5	300	500	394																																		
225 S	999	1146	313	538	456																																		
225 M	1092	1239	313	538	456																																		



Type	Motor	A	A1	H	HD	AC	Ød	l	t	u	l1	l2	w1	h	h1	h2	h3	h4	a	a1	a2	Øs1	w	i	Øp	Øf	ØD	s	Figure	m	i1	s2	m1	n	b	b1
YPM 142/ 143	132 S	723	827	193	325	262	110	415	116.4	28	138	375	187	142	391	550	242	858	376	530	520	33	79	270	-	-	350	-	-	70	450	M30	55	45	21	9
	132 M	768	872	193	325	262																														
	160 M	879	996	240	400	315																														
	160 L	924	1041	240	400	315																														
	180 M	936	1072	260	440	357																														
	180 L	973	1109	260	440	357																														
	200 L	1067,5	1214,5	300	500	394																														
	225 S	1026	1173	313	538	456																														
	225 M	1119	1266	313	538	456																														
	250 M	1132	1279	366	616	489																														
	280 S	1193	1441	398	678	547,5																														
	280 M	1193	1441	398	678	547,5																														
YPM 152/ 153	160 M	964	1081	240	400	315	120	500	127.4	32	170	460	240	170	460	660	285	1024	452	660	620	33	118	310	-	-	344	-	-	80	540	M36	68	55	24	10
	160 L	1009	1126	240	400	315																														
	180 M	1021	1157	260	440	357																														
	180 L	1058	1194	260	440	357																														
	200 L	1152,5	1299,5	300	500	394																														
	225 S	1111	1258	313	538	456																														
	225M	1204	1351	313	538	456																														
	250 M	1217	1364	366	616	489																														
	280 S	1278	1526	398	678	547,5																														
	280 M	1278	1526	398	678	547,5																														
	315 S	1483	1731	518	833	652																														
	315 M	1483	1741	518	833	652																														
315 L	1553	1811	518	833	652																															

The parallel helical shaft gear units YP series remain the optimal solution for complex and space limited applications. The fully reversible design of the gearbox offers a large range of mounting positions. The gears combinations allow high loads and the options for low output speed makes it the ideal solution for a very large range of applications.

Les réducteurs à arbres parallèles de la série YP restent la solution optimale pour les applications complexes et peu encombrantes. La conception entièrement réversible de la boîte de vitesses offre une large gamme de positions de montage. Les combinaisons d'engrenages permettent des charges élevées et les options de faible vitesse de sortie en font la solution idéale pour une très large gamme d'applications.

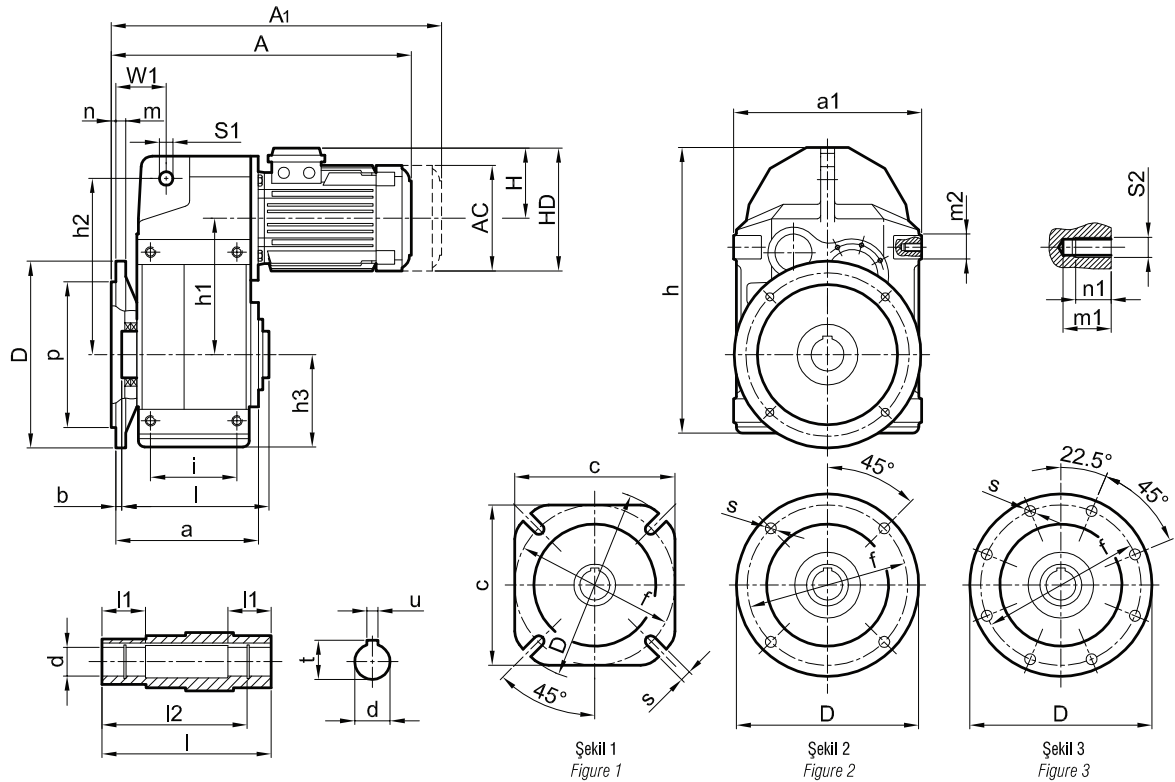

Şekil 1  
Figure 1

Şekil 2  
Figure 2

Şekil 3  
Figure 3

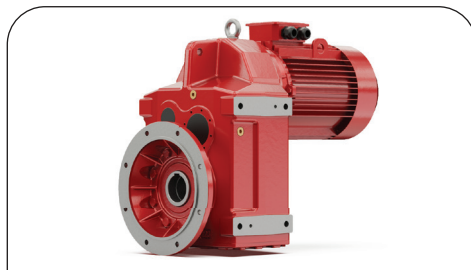

Type Type	Torque (Max) Couple (Max)	Shaft Diameter Diamètre de l'arbre de sortie
YPF 42-43	130 Nm	Ø 25
YPF 52-53	200 Nm	Ø 30
YPF 62-63	400 Nm	Ø 35
YPF 72-73-74	820 Nm	Ø 40
YPF 82-83-84	1500 Nm	Ø 50
YPF 92-93-94	3000 Nm	Ø 60
YPF 102-103-104	4300 Nm	Ø 70
YPF 122-123-124	7800 Nm	Ø 90
YPF 142-143-144	13000 Nm	Ø 110
YPF 152-153-154	18000 Nm	Ø 120

**Output Shaft Applications / Spécificités de l'arbre de sortie**

YPF Type Gearboxes have solid shaft Output.  
 Les motoréducteurs du type YPF dispose d'arbre de sorties pleins ou creux.

**Speed Range / Vitesse**

2,4 d/d ... 391 d/d

**Applicable Motor Power / Puissance moteur applicable**

0,12 kW ... 200 kW

**Mounting Positions / Position de montage**

You can choose from foot and flange mounting options according to your need.  
 Disponible monté sur pied ou libre, en fonction de vos besoins.

**Input Options / Options d'entrée**

Helical gear units [YPF] Réducteurs sans moteur  
 Helical gear units [YFPF](IEC) Réducteurs avec adaptateur normalisé sans moteur  
 Helical geared motors [YPFM] Réducteurs avec moteur  
 Helical geared motors [YFPFM](IEC) Réducteurs avec adaptateur normalisé et moteur

**Brake Types / Types de freins**

24V DC or 220v AC electromagnetic brakes.  
 Freins électromagnétiques 24V DC ou 220V AC.



Type	Motor	A	A1	H	HD	AC	Ød	l	t	u	l1	l2	w1	h	h1	h2	h3	a	a1	Øs1	i	Øp	Øf	ØD	Figure	c	Øs	m	n	s2	m1	n1	m2	b
YPFM 42 / 43	63 M	328,5	382,5	108	171	125	25	106	28,3	8	36	90	45	225	102	140	73	122	150	14	65	110	130	160	1	130	9	10	3,5	M8	14	10	20	20
	71 M	324,5	378,5	123	194	138,5																												
	80 M	396	457	136	216	158																												
	90 S	387	454	141	231	176																												
	90 L	451	518	141	231	176																												
YPFM 52 / 53	63 M	342,5	396,5	108	171	125	30	118	33,3	8	39	102	55,5	264	115	158	79	139	172	14	77	110	130	160	2	-	9	10	3,5	M8	17	14	24	24
	71 M	338,5	392,5	123	194	138,5																												
	80 M	410	471	136	216	158																												
	90 S	401	468	141	231	176																												
	90 L	465	532	141	231	176																												
	100 L	505	582	161	261	195																												
YPFM 62 / 63	63 M	369,5	423,5	108	171	125	35	150	38,3	10	50	130	57	300	131	170	88	171,5	195	14	93	130	165	200	1	170	11	12	3,5	M10	19	16	26	25
	71 M	358,5	412,5	123	194	138,5																												
	80 M	431	492	136	216	158																												
	90 S	424	491	141	231	176																												
	90 L	488	555	141	231	176																												
	100 L	527	604	161	261	195																												
	112 M	498,5	593,5	170	282	220																												
YPFM 72 / 73	63 M	393,5	447,5	108	171	125	40	180	43,3	12	60	155	76	349	159	218	110	210	234	14	112	180	215	250	1	215	13	14	4	M10	20	26	28	35
	71 M	382,5	436,5	123	194	138,5																												
	80 M	455	516	136	216	158																												
	90 S	448	515	141	231	176																												
	90 L	512	579	141	231	176																												
	100 L	551	628	161	261	195																												
	112 M	522,5	617,5	170	282	220																												
	132 S	578	682	193	325	262																												
	132 M	623	727	193	325	262																												
	YPFM 82 / 83	71 M	404,5	458,5	123	194																												
80 M		477,5	538,5	136	216	158																												
90 S		470,5	537,5	141	231	176																												
90 L		534,5	601,5	141	231	176																												
100 L		576,5	653,5	161	261	195																												
112 M		551	646	170	282	220																												
132 S		607	711	193	325	262																												
132 M		652	756	193	325	262																												



Type	Motor	A	A1	H	HD	AC	Ød	l	t	u	l1	l2	w1	h	h1	h2	h3	a	a1	Øs1	i	Øp	Øf	ØD	Figure	c	Øs	m	n	s2	m1	n1	m2	b
YPFM 92 / 93	80 M	500	561	136	216	158	60	243	64,4	18	80	212	105	515	241	331	149	281	325	22	165	250	300	350	1	300	18	18	5	M14	33	28	40	43
	90 S	490	557	141	231	176																												
	90 L	554	621	141	231	176																												
	100 L	595	672	161	261	195																												
	112 M	568,5	663,5	170	282	220																												
	132 S	636	740	193	325	262																												
	132 M	681	785	193	325	262																												
	160 M	754	871	240	400	315																												
	160 L	799	916	240	400	315																												
	180 M	808,5	944,5	260	440	357																												
180 L	845,5	981,5	260	440	357																													
YPFM 102 / 103	90 S	627	694	141	231	176	70	310	74,9	20	103	279	111	622	294	395	178	311,5	403	26	205	300	350	400	2	-	18	20	5	M16	35	30	50	16,5
	90 L	665	732	141	231	176																												
	100 L	637,5	714,5	161	261	195																												
	112 M	611	706	170	282	220																												
	132 S	672,5	776,5	193	325	262																												
	132 M	717,5	821,5	193	325	262																												
	160 M	813	930	240	400	315																												
	160 L	858	975	240	400	315																												
180 M	876	1012	260	440	357																													
180 L	913	1049	260	440	357																													
200 L	991,5	1138,5	300	500	394																													
YPFM 122 / 123	100 L	677	754	161	261	195	90	360	95,4	25	121	320	154	712	333	460	204	418	470	26	220	350	400	450	3	-	18	22	5	M24	42	34	60	66
	112 M	642,5	737,5	170	282	220																												
	132 S	710	814	193	325	262																												
	132 M	755	859	193	325	262																												
	160 M	832	949	240	400	315																												
	160 L	877	994	240	400	315																												
	180 M	904,5	1040,5	260	440	357																												
	180 L	941,5	1077,5	260	440	357																												
	200 L	1039,5	1186,5	300	500	394																												
	225 S	999	1146	313	538	456																												
225 M	1092	1239	313	538	456																													



Type	Motor	A	A1	H	HD	AC	Ød	l	t	u	l1	l2	w1	h	h1	h2	h3	a	a1	Øs1	i	Øp	Øf	ØD	Figure	c	Øs	m	n	s2	m1	n1	m2	b				
YPFM 142/ 143	132 S	723	827	193	325	262																																
	132 M	768	872	193	325	262																																
	160 M	879	996	240	400	315																																
	160 L	924	1041	240	400	315																																
	180 M	936	1072	260	440	357																																
	180 L	973	1109	260	440	357	110	415	116.4	28	138	375	187	858	391	550	242	486	530	33	270	450	500	550	3	-	18	25	5	M30	55	45	70	77				
	200 L	1067.5	1214.5	300	500	394																																
	225 S	1026	1173	313	538	456																																
	225 M	1119	1266	313	538	456																																
	250 M	1132	1279	366	616	489																																
	280 S	1193	1441	398	678	547.5																																
	280 M	1193	1441	398	678	547.5																																
YPFM 152/ 153	160 M	964	1081	240	400	315																																
	160 L	1009	1126	240	400	315																																
	180 M	1021	1157	260	440	357																																
	180 L	1058	1194	260	440	357																																
	200 L	1152.5	1299.5	300	500	394																																
	225 S	1111	1258	313	538	456																																
	225 M	1204	1351	313	538	456	120	500	127.4	32	170	460	240	1024	460	660	285	580	660	33	310	550	600	660	3	-	22	30	6	M36	68	55	80	90				
	250 M	1217	1364	366	616	489																																
	280 S	1278	1526	398	678	547.5																																
	280 M	1278	1526	398	678	547.5																																
	315 S	1483	1731	518	833	652																																
	315 M	1483	1741	518	833	652																																
315 L	1553	1811	518	833	652																																	

Developed for lifting and hoisting technologies, the new IRC Series offer a large range of options and solutions. Composed of three steps of gears the IRC Series is available in five different sizes. Available in 6 different sizes of housing, the IRC Series covers a large range of the hoisting industry needs.

*Développée pour les technologies de levage et de levage, la nouvelle série IRC offre une large gamme d'options et de solutions. Composée de trois étapes d'engrenages, la série IRC est disponible en cinq tailles différentes. Disponible en 6 tailles de boîtier différentes, la série IRC couvre une large gamme de besoins de l'industrie du levage.*

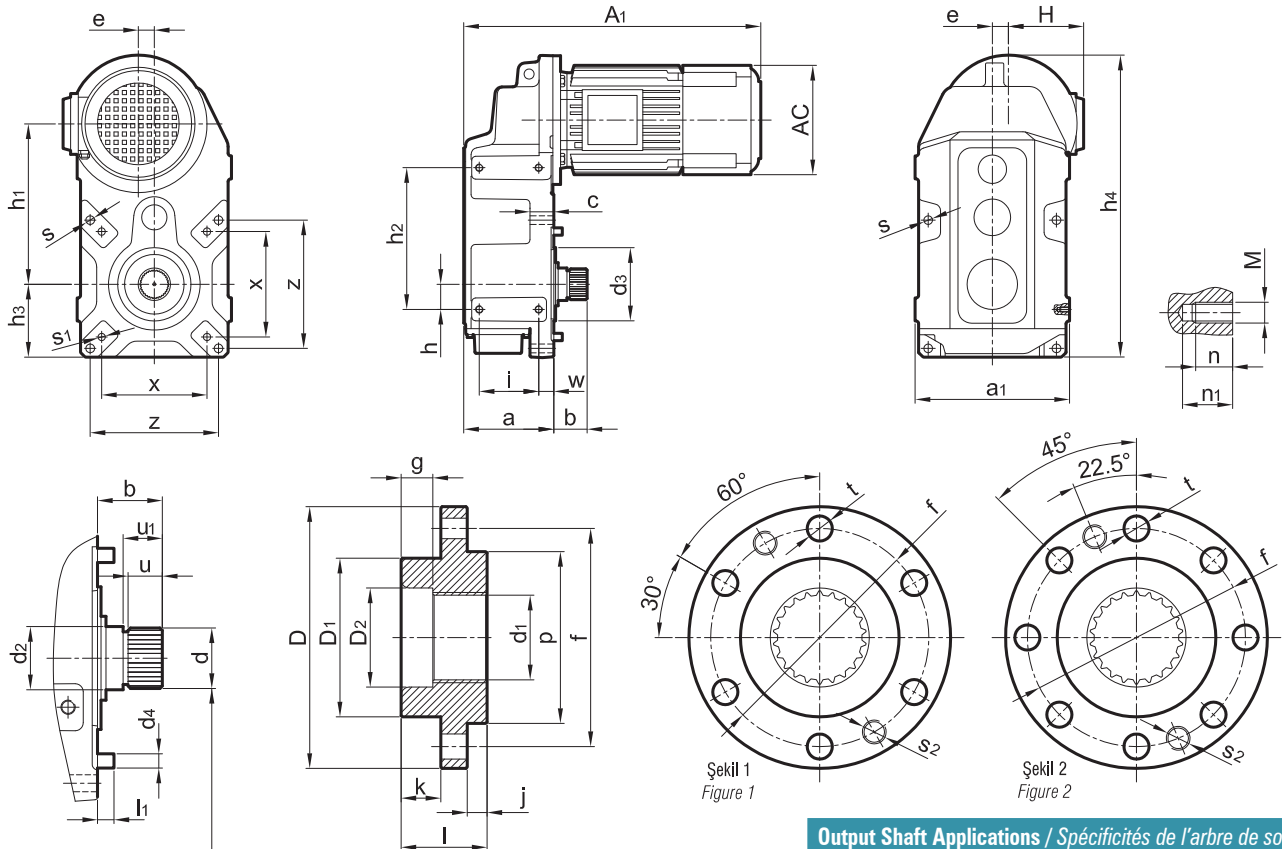

İRCM 73	W45x2x30x21x8f	DIN 5480
İRCM 83	W50x2x30x24x8f	
İRCM 93	W70x3x30x22x8f	
İRCM 103	W95x3x30x30x8f	
İRCM 123	W110x4x30x26x8f	
İRCM 143	W120x4x30x28x8f	

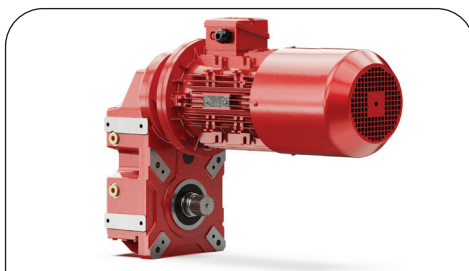

Type Type	Torque (Max) Couple (Max)	Shaft Diameter Diamètre de l'arbre de sortie
İRCM 73	800 Nm	Ø 45
İRCM 83	1500 Nm	Ø 50
İRCM 93	3500 Nm	Ø 70
İRCM 103	7500 Nm	Ø 95
İRCM 123	10400 Nm	Ø 110
İRCM 143	19200 Nm	Ø 120

**Output Shaft Applications / Spécificités de l'arbre de sortie**

IRC type of gearboxes are available with splined shaft  
*Les motoréducteurs du type IRC disposent d'arbres de sorties cannelés*

**Speed Range / Vitesse**

7 d/d ... 59 d/d

**Applicable Motor Power / Puissance moteur applicable**

0,37 kW ... 45 kW

**Mounting Positions / Position de montage**

IRC gearboxes are available with various mounting configurations.  
*Les réducteurs IRC sont disponibles dans de multiples configurations.*

**Input Options / Options d'entrée**

Helical gear units [IRC] Réducteurs sans moteur  
 Helical gear units [IRCP](IEC) Réducteurs avec adaptateur normalisé sans moteur  
 Helical geared motors [İRCM] Réducteurs avec moteur  
 Helical geared motors [İRCPM](IEC) Réducteurs avec adaptateur normalisé et moteur

**Brake Types / Types de freins**

24V DC or 220v AC electromagnetic brakes.  
*Freins électromagnétiques 24V DC ou 220V AC.*



Designed to last, the helical bevel gear units IRK series are perfectly adapted for applications in need of high efficiency gearboxes. The gear design also offers a quiet operation of this unit. These advantages offer to you the guarantee of a noise free and low maintenance gearbox.

*Conçus pour durer, les réducteurs à couple conique de la série IRK sont parfaitement adaptés aux applications nécessitant des réducteurs à haut rendement. La conception de l'engrenage offre également un fonctionnement silencieux de cet appareil. Ces avantages vous offrent la garantie d'un réducteur silencieux et nécessitant peu d'entretien.*

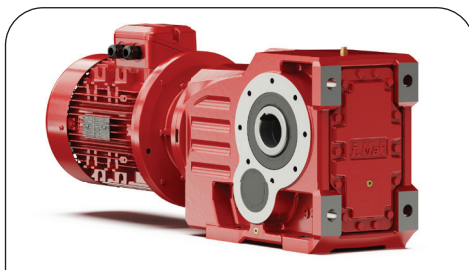
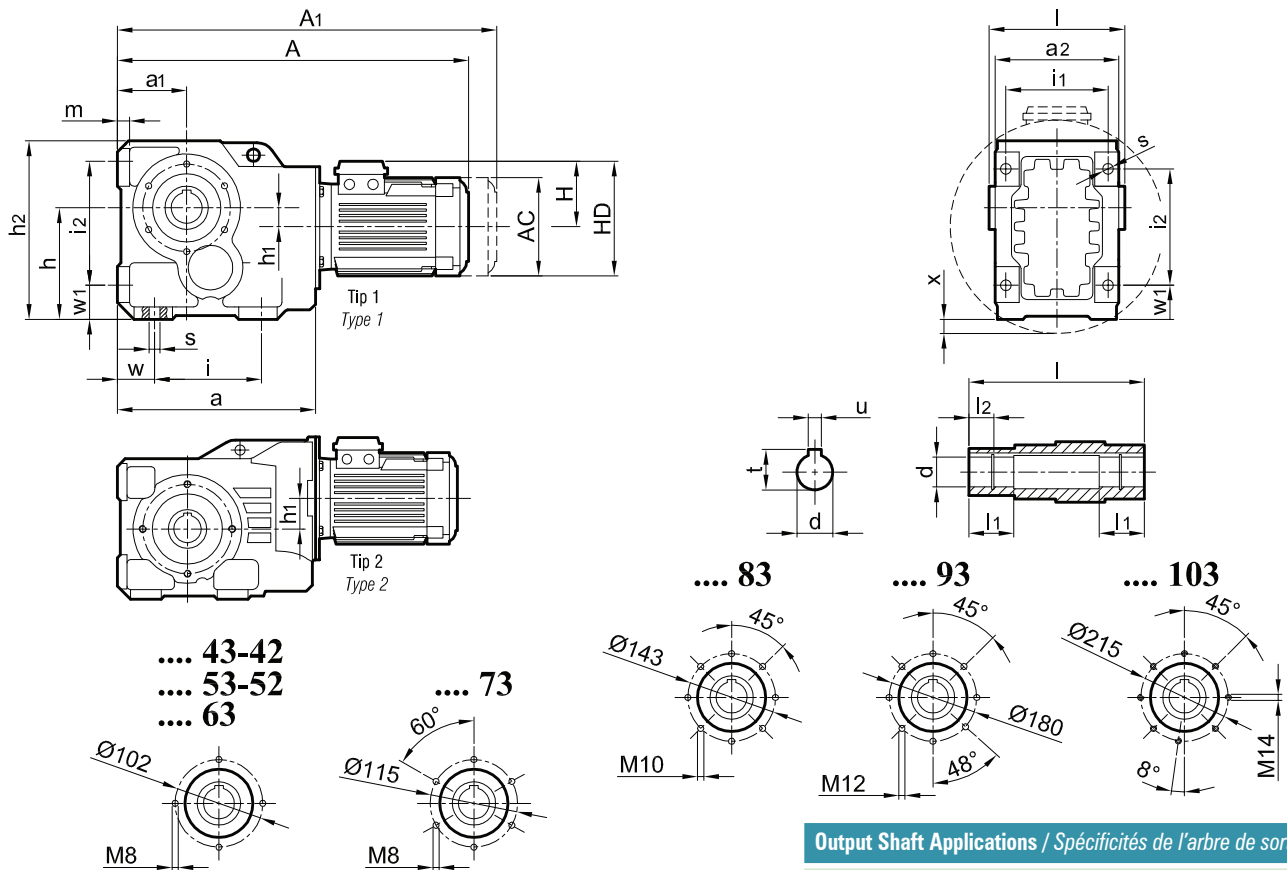

Type Type	Torque (Max) Couple (Max)	Shaft Diameter Diamètre de l'arbre de sortie
IRK 42-43	180 Nm	Ø 30
IRK 52-53	220 Nm	Ø 30
IRK 63	400 Nm	Ø 35
IRK 73-74	780 Nm	Ø 40
IRK 83-84	1330 Nm	Ø 50
IRK 93-94	2572 Nm	Ø 60
IRK 103-104	4010 Nm	Ø 70
IRK 123-124	8000 Nm	Ø 90
IRK 142-143-144	13000 Nm	Ø 110
IRK 153-154	18000 Nm	Ø 120

**Output Shaft Applications / Spécificités de l'arbre de sortie**

IRK Type Gearboxes have solid shaft Output.  
*Les motorréducteurs du type IRK dispose d'arbre de sorties pleins ou creux.*

**Speed Range / Vitesse**

0,17 d/d ... 214 d/d

**Applicable Motor Power / Puissance moteur applicable**

0,12 kW ... 200 kW

**Mounting Positions / Position de montage**

You can choose from foot and flange mounting options according to your need.  
*Disponible monté sur pied ou libre, en fonction de vos besoins.*

**Input Options / Options d'entrée**

Helical gear units [IRK] Réducteurs sans moteur  
Helical gear units [IRKP](IEC) Réducteurs avec adaptateur normalisé sans moteur  
Helical geared motors [IRKM] Réducteurs avec moteur  
Helical geared motors [IRKPM](IEC) Réducteurs avec adaptateur normalisé et moteur

**Brake Types / Types de freins**

24V DC or 220v AC electromagnetic brakes.  
*Freins électromagnétiques 24V DC ou 220V AC.*



Tip Typ	Motor Motor	A	A1	H	HD	AC	x	Ød	l	t	u	l1	l2	h	a1	Øs	m	Type	h1	w	i	i1	a	h2	w1	i2	a2
IRKM 43-42	63 M	459	513	108	171	125	-	30	140	33,3	8	47	20	80	80	9	11	2	34,91	30	100	100	226	160	25	110	133
	71 M	455	509	123	194	139	-																				
	80 M	525	586	136	216	158	-																				
	90 S	517	584	141	231	176	-																				
	90 L	581	648	141	231	176	-																				
	100 L	621	698	161	261	195	-																				
IRKM 53-52	63 M	459	513	108	171	125	-	30	140	33,3	8	47	20	100	63	11	12	2	34,91	35	110	100	209	180	32	115	133
	71 M	455	509	123	194	139	-																				
	80 M	525	586	136	216	158	-																				
	90 S	517	584	141	231	176	-																				
	90 L	581	648	141	231	176	-																				
	100 L	621	698	161	261	195	-																				
IRKM 63	63 M	483	537	108	171	125	-	35	150	38,3	10	50	20	112	75	11	13	1	11,45	40	130	120	250	195	40	130	145
	71 M	479	533	123	194	139	-																				
	80 M	549	610	136	216	158	-																				
	90 S	541	608	141	231	176	-																				
	90 L	605	672	141	231	176	-																				
	100 L	645	722	161	261	195	-																				
IRKM 73	63 M	508	562	108	171	125	-	40	180	43,3	12	60	25	140	90	13	16	1	17,27	60	120	140	275	232	45	160	170
	71 M	497	551	123	194	139	-																				
	80 M	569	630	136	216	158	-																				
	90 S	562	629	141	231	176	-																				
	90 L	626	693	141	231	176	-																				
	100 L	665	742	161	261	195	-																				
	112 M	637	732	170	282	220	-																				
	132 S	692	796	193	325	262	2																				
IRKM 83	71 M	544	598	123	194	139	-	50	210	53,8	14	70	30	180	112	17,5	20	1	30,51	72	150	165	331	288	55	200	200
	80 M	617	678	136	216	158	-																				
	90 S	610	677	141	231	176	-																				
	90 L	674	741	141	231	176	-																				
	100 L	715	792	161	261	195	-																				
	112 M	690	785	170	282	220	-																				
	132 S	761	865	193	325	262	-																				
	132 M	806	910	193	325	262	-																				
160 M	889	1006	240	400	315	8																					

Tip Typ	Motor Motor	A	A1	H	HD	AC	x	Ød	l	t	u	l1	l2	h	a1	Øs	m	Type	h1	w	i	i1	a	h2	w1	i2	a2
IRKM 93	80 M	678	739	136	216	158	-	60	243	64,4	18	80	31	212	132	22	25	1	27,08	77	180	180	402	350	70	233	230
	90 S	669	736	141	231	176	-																				
	90 L	733	800	141	231	176	-																				
	100 L	773	850	161	261	195	-																				
	112 M	747	842	170	282	220	-																				
	132 S	817	921	193	325	262	-																				
	132 M	862	966	193	325	262	-																				
	160 M	931	1048	240	400	315	-																				
	160 L	976	1093	240	400	315	-																				
	180 M	987	1123	260	440	357	-																				
	180 L	1024	1160	260	440	357	-																				
IRKM 103	90 S	821	888	141	231	176	-	70	310	74,9	20	103	31	265	160	26	32	1	33	85	240	240	470	422	75	295	390
	90 L	859	926	141	231	176	-																				
	100 L	831	908	161	261	195	-																				
	112 M	805	900	170	282	220	-																				
	132 S	867	971	193	325	262	-																				
	132 M	912	1016	193	325	262	-																				
	160 M	1007	1124	240	400	315	-																				
	160 L	1052	1169	240	400	315	-																				
	180 M	1064	1200	260	440	357	-																				
	180 L	1101	1237	260	440	357	-																				
	200 L	1186	1333	300	500	394	-																				
IRKM 123	100 L	929	1006	161	261	195	-	90	360	95,4	25	121	40	315	200	28	36	1	57,68	105	280	270	562	515	95	360	345
	112 M	900	995	170	282	220	-																				
	132 S	950	1054	193	325	262	-																				
	132 M	995	1099	193	325	262	-																				
	160 M	1073	1190	240	400	315	-																				
	160 L	1118	1235	240	400	315	-																				
	180 M	1145	1281	260	440	357	-																				
	180 L	1182	1318	260	440	357	-																				
	200 L	1280	1427	300	500	394	-																				
	225 S	1239	1386	313	538	456	-																				
	225 M	1332	1479	313	538	456	-																				
IRKM 143	132 S	1059	1163	193	325	262	-	110	415	116,4	28	138	40	375	225	38	45	1	59,4	110	350	330	683	598	110	420	403
	132 M	1104	1208	193	325	262	-																				
	160 M	1190	1307	240	400	315	-																				
	160 L	1235	1352	240	400	315	-																				
	180 M	1249	1385	260	440	357	-																				
	180 L	1286	1422	260	440	357	-																				
	200 L	1381	1528	300	500	394	-																				
	225 S	1339	1486	313	538	456	-																				
	225 M	1432	1579	313	538	456	-																				
	250 M	1445	1592	366	616	489	-																				
	280 S	1506	1754	398	678	548	-																				
	280 M	1506	1754	398	678	548	-																				



Tip Typ	Motor Motor	A	A1	H	HD	AC	x	Ød	l	t	u	l1	l2	h	a1	Øs	m	Type	h1	w	i	i1	a	h2	w1	i2	a2
IRKM 153	160 M	1274	1391	240	400	315	-	120	500	127,4	32	200	40	450	280	38	50	1	73,13	140	380	420	765	710	130	500	486
	160 L	1319	1436	240	400	315	-																				
	180 M	1331	1467	260	440	357	-																				
	180 L	1368	1504	260	440	357	-																				
	200 L	1463	1610	300	500	394	-																				
	225 S	1421	1568	313	538	456	-																				
	225 M	1514	1661	313	538	456	-																				
	250 M	1527	1674	366	616	489	-																				
	280 S	1588	1836	398	678	548	-																				
	280 M	1588	1836	398	678	548	-																				
	315 S	1793	2041	518	833	652	-																				
	315 M	1793	2041	518	833	652	-																				
	315 M	1793	2051	518	833	652	-																				
	315 L	1863	2121	518	833	652	-																				
	315 L	1863	2121	518	833	652	-																				



Designed to last, the helical bevel gear units IRK series are perfectly adapted for applications in need of high efficiency gearboxes. The gear design also offers a quiet operation of this unit. These advantages offer to you the guarantee of a noise free and low maintenance gearbox.

*Conçus pour durer, les réducteurs à couple conique de la série IRK sont parfaitement adaptés aux applications nécessitant des réducteurs à haut rendement. La conception de l'engrenage offre également un fonctionnement silencieux de cet appareil. Ces avantages vous offrent la garantie d'un réducteur silencieux et nécessitant peu d'entretien.*

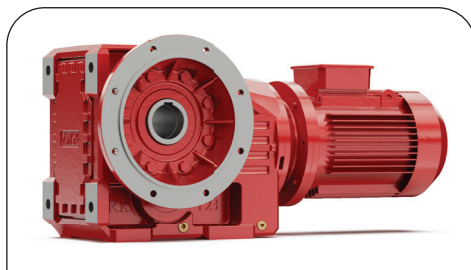
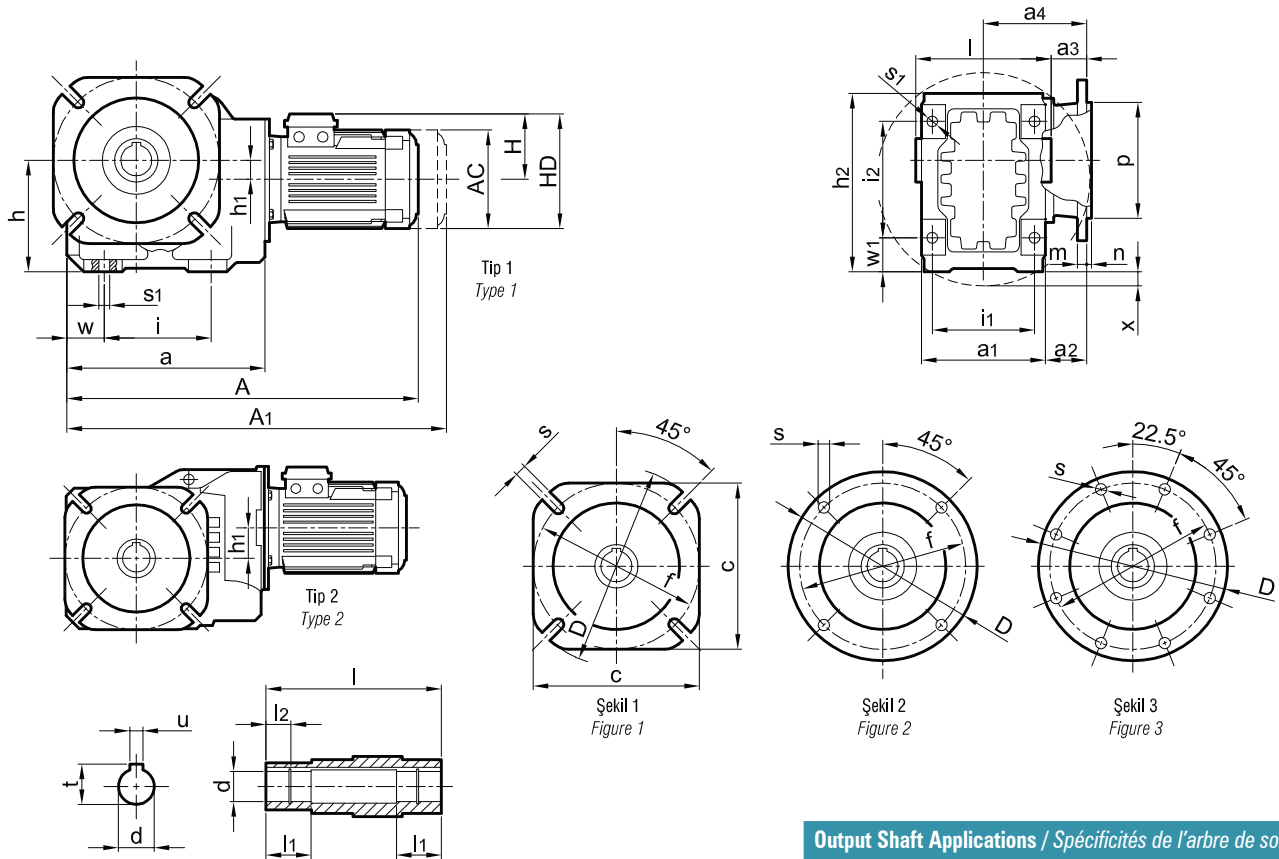

Type Type	Torque (Max) Couple (Max)	Shaft Diameter Diamètre de l'arbre de sortie
IRKF 42-43	180 Nm	Ø 30
IRKF 52-53	220 Nm	Ø 30
IRKF 63	400 Nm	Ø 35
IRKF 73-74	780 Nm	Ø 40
IRKF 83-84	1330 Nm	Ø 50
IRKF 93-94	2572 Nm	Ø 60
IRKF 103-104	4010 Nm	Ø 70
IRKF 123-124	8000 Nm	Ø 90
IRKF 142-143-144	13000 Nm	Ø 110
IRKF 153-154	18000 Nm	Ø 120

**Output Shaft Applications / Spécificités de l'arbre de sortie**

IRKF Type Gearboxes have solid shaft Output.  
*Les motoréducteurs du type IRKF dispose d'arbre de sorties pleins ou creux.*

**Speed Range / Vitesse**

0,17 d/d ... 214 d/d

**Applicable Motor Power / Puissance moteur applicable**

0,12 kW ... 200 kW

**Mounting Positions / Position de montage**

You can choose from foot and flange mounting options according to your need.  
*Disponible monté sur pied ou libre, en fonction de vos besoins.*

**Input Options / Options d'entrée**

Helical gear units [IRKF] *Réducteurs sans moteur*  
Helical gear units [IRKFP](IEC) *Réducteurs avec adaptateur normalisé sans moteur*  
Helical geared motors [IRKFM] *Réducteurs avec moteur*  
Helical geared motors [IRKFPM](IEC) *Réducteurs avec adaptateur normalisé et moteur*

**Brake Types / Types de freins**

24V DC or 220v AC electromagnetic brakes.  
*Freins électromagnétiques 24V DC ou 220V AC.*



Type	Mot or	A	A1	H	HD	AC	x	Ød	l	t	u	l1	l2	Øp	Øf	ØD	Figure	c	Øs	m	n	a3	h	Type	h1	h2	Øs1	w	i	i1	a	a1	w1	i2	a2	a4
IRKFM 43-42	63 M	459	512,5	108	171	125	-	30	140	28,3	8	47	20	110	130	160	1	140	9	10	3,5	25,5	80	2	34,91	160	9	25	100	100	209	133	25	110	133	95,5
	71 M	454,5	508,5	123	194	138,5	-																													
	80 M	525	586	136	216	158	-																													
	90 S	517	584	141	231	176	-																													
	90 L	581	648	141	231	176	-																													
	100 L	621	698	161	261	195	-																													
IRKFM 53-52	63 M	458,5	512,5	108	171	125	-	30	140	28,3	8	47	20	110	130	160	1	140	9	10	3,5	25,5	80	2	34,91	180	11	32	110	120	226	133	32	115	133	95,5
	71 M	454,5	508,5	123	194	138,5	-																													
	80 M	525	586	136	216	158	-																													
	90 S	517	584	141	231	176	-																													
	90 L	581	648	141	231	176	-																													
	100 L	621	698	161	261	195	-																													
IRKFM 63	63 M	482,5	536,5	108	171	125	-	35	150	38,3	10	47	20	130	165	200	1	170	11	12	3,5	25	112	1	11,45	195	11	40	130	120	250	145	37	130	28	100
	71 M	478,5	532,5	123	194	138,5	-																													
	80 M	549	610	136	216	158	-																													
	90 S	541	608	141	231	176	-																													
	90 L	605	672	141	231	176	-																													
	100 L	645	722	161	261	195	-																													
IRKFM 73	63 M	508	562	108	171	125	-	40	180	43,3	12	60	25	180	215	250	1	215	13	14	4	35	140	1	17,27	232	13	60	120	140	275	170	45	160	40	125
	71 M	497	551	123	194	138,5	-																													
	80 M	569	630	136	216	158	-																													
	90 S	562	629	141	231	176	-																													
	90 L	626	693	141	231	176	-																													
	100 L	665	742	161	261	195	-																													
	112 M	637	732	170	282	220	-																													
	132 S	692	796	193	325	262	2																													
IRKFM 83	71 M	544	598	123	194	138,5	-	50	210	53,8	14	70	30	230	265	300	1	256	13	16	4	37	180	1	30,51	288	17,5	72	150	165	331	200	55	200	42	142
	80 M	617	678	136	216	158	-																													
	90 S	610	677	141	231	176	-																													
	90 L	674	741	141	231	176	-																													
	100 L	715	792	161	261	195	-																													
	112 M	690	785	170	282	220	-																													
	132 S	761	865	193	325	262	-																													
	160 M	889	1006	240	400	315	8																													





Available in six different stages, the S Series provide optimal solutions for a large range of application. The aluminium housing of the gearbox and the gears technology is offering a perfect balance between power and space optimization. Compact and modular, the S Serie is the perfect solution for a wide range of applications and sectors.

*Disponible en six étapes différentes, la série S fournit des solutions optimales pour une large gamme d'applications. Le carter en aluminium de la boîte de vitesses et la technologie des engrenages offrent un équilibre parfait entre puissance et optimisation de l'espace. Compacte et modulaire, la série S est la solution parfaite pour un large éventail d'applications et de secteurs.*

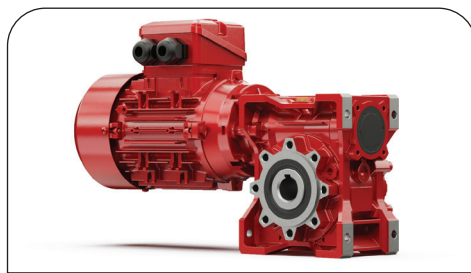
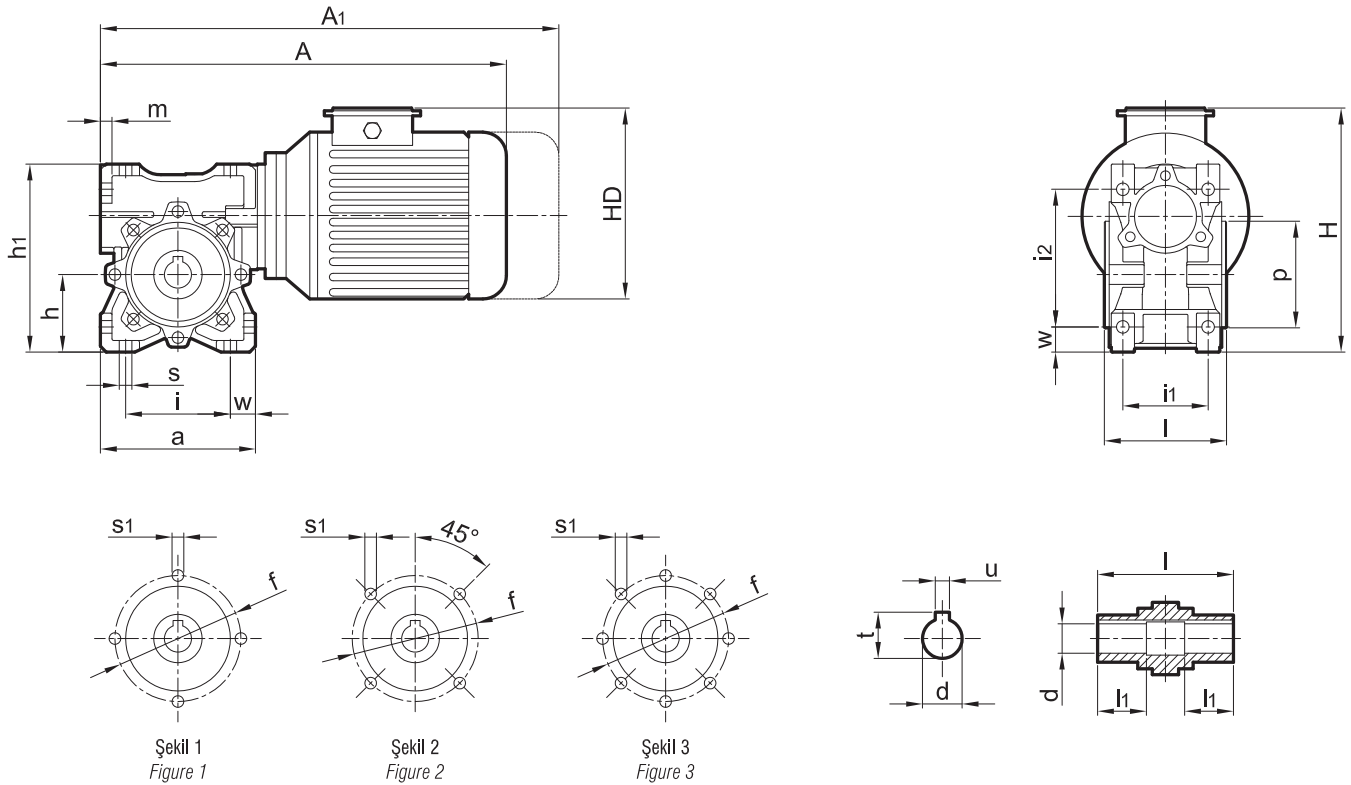

Type Type	Torque (Max) Couple (Max)	Shaft Diameter Diamètre de l'arbre de sortie
S 30	21 Nm	Ø 14
S 40	42 Nm	Ø 18
S 50	71 Nm	Ø 25
S 63	145 Nm	Ø 25
S 75	221 Nm	Ø 28
S 90	400 Nm	Ø 35
S 110	700 Nm	Ø 42
S 130	1000 Nm	Ø 45
S 150	1500 Nm	Ø 50

**Output Shaft Applications / Spécificités de l'arbre de sortie**

SM Type Gearboxes have solid shaft output.  
*Les motoréducteurs du type SM dispose d'arbre de sortie solides.*

**Range of Ratios / Rapports de réduction**

7,5...100

**Applicable Motor Power / Puissance moteur applicable**

0,12 kW ... 15 kW

**Mounting Positions / Position de montage**

You can choose from Foot and Flange mounting options according to your need.  
*Disponible monté sur pied ou pendulaire, en fonction de vos besoins.*

**Input Options / Options d'entrée**

Worm gear unit [S] Réducteur à vis sans fin

Worm gear unit with (IEC) [SP] Réducteur à vis sans fin avec (IEC)

Worm gear unit with motor [SM] Réducteur à vis sans fin avec moteur

**Brake Types / Types de freins**

24V DC or 220v AC electromagnetic brakes.  
*Freins électromagnétiques 24V DC ou 220V AC.*



Type	Motor	A	A1	H	HD	Ød	l	t	u	l1	h	h1	Øs	m	i	w	i1	a	Øp	Øf	Figure	s1	i2
SM 30	63 M	292	346	179	171	14	63	16,3	5	22	40	97	6,5	6	54	13	44	80	55	65	1	M6	71
	63 M	317	371	199	171	18	78	20,8	6	23	50	121,5	6,5	6,5	70	15	60	100	60	75	2	M6	90
SM 40	71 M	350	404	215	194																		
SM 50	63 M	337	391	219	171	25	92	28,3	8	30	60	144	8,5	7	80	20	70	120	70	85	2	M8	104
	71 M	370	424	235	194																		
	80 M	433	494	247	216																		
SM 63	71 M	397	451	260	194	25	112	28,3	8	36	72	174	9	8	100	22	85	144	80	95	3	M8	130
	80 M	460	521	272	216																		
	90 S	469	536	278	231																		
	90 L	507	574	278	231																		
SM 75	80 M	489	550	298	216	28	120	31,3	8	40	86	205	11	10	120	26	90	172	95	115	3	M8	153
	90 S	498	565	304	231																		
	90 L	536	603	304	231																		
	100 L	568	645	325	261																		
SM 90	80 M	524	585	330	216	35	140	38,3	10	45	103	238	13	11	140	33	100	206	110	130	3	M10	172
	90 S	533	600	336	231																		
	90 L	571	638	336	231																		
	100 L	603	680	357	261																		
	112 M	575	670	365	282																		
SM 110	80 M	581	642	375	216	42	155	45,3	12	50	127,5	295	14	14,5	170	42,5	115	252,5	130	165	3	M10	210
	90 S	590	657	381	231																		
	90 L	628	695	381	231																		
	100 L	660	737	401	261																		
	112 M	632	727	410	282																		
	132 S	689	793	432	325																		
	132 M	730	834	432	325																		
SM 130	90 S	630	697	421	231	45	170	48,8	14	55	147,5	335	16	15,5	200	47,5	120	292,5	180	215	3	M12	240
	90 L	668	735	421	231																		
	100 L	700	777	441	261																		
	112 M	672	767	450	282																		
	132 S	729	833	472	325																		
	132 M	770	874	472	325																		
SM 150	100 L	752	829	484	261	50	200	53,8	14	65	170	400	18	18	240	50	145	340	180	215	3	M12	300
	112 M	724	819	492	282																		
	132 S	781	885	514	325																		
	132 M	822	926	514	325																		
	160 M	900	1017	563	400																		
	160 L	945	1062	563	400																		

Available in six different stages, the S Series provide optimal solutions for a large range of application. The aluminium housing of the gearbox and the gears technology is offering a perfect balance between power and space optimization. Compact and modular, the S Serie is the perfect solution for a wide range of applications and sectors.

*Disponible en six étapes différentes, la série S fournit des solutions optimales pour une large gamme d'applications. Le carter en aluminium de la boîte de vitesses et la technologie des engrenages offrent un équilibre parfait entre puissance et optimisation de l'espace. Compacte et modulaire, la série S est la solution parfaite pour un large éventail d'applications et de secteurs.*

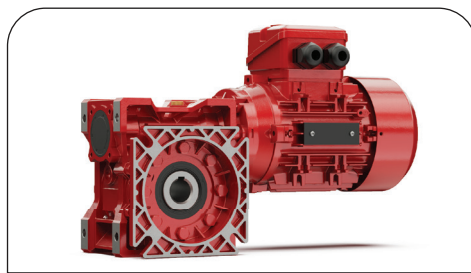
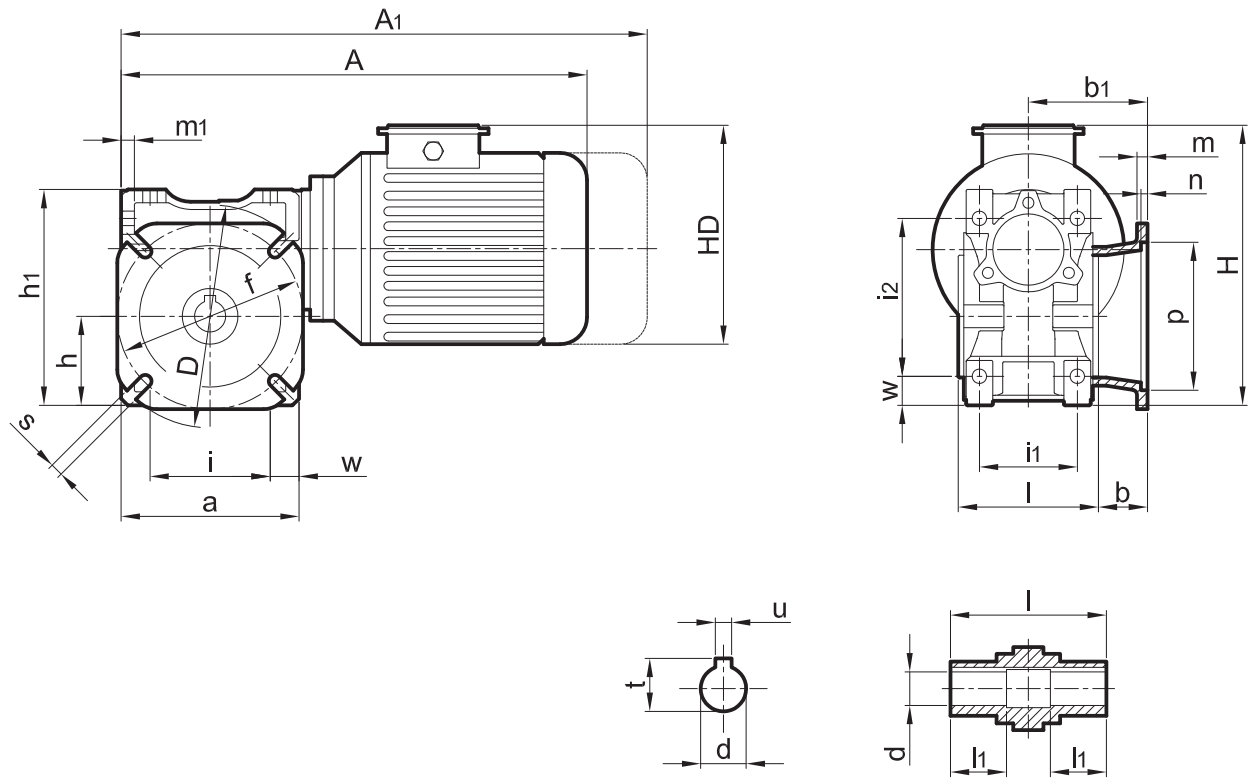

Type Type	Torque (Max) Couple (Max)	Shaft Diameter Diamètre de l'arbre de sortie
S 30	21 Nm	Ø 14
S 40	42 Nm	Ø 18
S 50	71 Nm	Ø 25
S 63	145 Nm	Ø 25
S 75	221 Nm	Ø 28
S 90	400 Nm	Ø 35
S 110	700 Nm	Ø 42
S 130	1000 Nm	Ø 45
S 150	1500 Nm	Ø 50

**Output Shaft Applications / Spécificités de l'arbre de sortie**

SFM Type Gearboxes have solid shaft output.  
*Les motoréducteurs du type SFM dispose d'arbre de sortie solides.*

**Range of Ratios / Rapports de réduction**

7,5...100

**Applicable Motor Power / Puissance moteur applicable**

0,12 kW ... 15 kW

**Mounting Positions / Position de montage**

You can choose from Foot and Flange mounting options according to your need.  
*Disponible monté sur pied ou pendulaire, en fonction de vos besoins.*

**Input Options / Options d'entrée**

- Worm gear unit [S] Réducteur à vis sans fin
- Worm gear unit with (IEC) [SP] Réducteur à vis sans fin avec (IEC)
- Worm gear unit with motor [SM] Réducteur à vis sans fin avec moteur

**Brake Types / Types de freins**

24V DC or 220v AC electromagnetic brakes.  
*Freins électromagnétiques 24V DC ou 220V AC.*

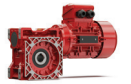

Type	Motor	A	A1	H	HD	Ød	l	t	u	l1	Øp	Øf	ØD	Øs	m	n	h	h1	m1	i	w	i1	a	i2	b	b1
SFM 30	63 M	292	346	179	171	14	63	16,3	5	22	50	65	80	6,5	6	4	40	97	6	54	13	44	80	71	23	54,5
SFM 40	63 M	317	371	199	171	18	78	20,8	6	23	60	75	110	9	7	4	50	121,5	6,5	70	15	60	100	90	28	67
	71 M	350	404	215	194																					
SFM 50	63 M	337	391	219	171	25	92	28,3	8	30	70	85	125	11	9	5	60	144	7	80	20	70	120	104	44	90
	71 M	370	424	235	194																					
	80 H	433	494	247	216																					
SFM 63	71 M	397	451	260	194	25	112	28,3	8	36	115	150	180	11	10	6	72	174	8	100	22	85	144	130	26	82
	80 H	460	521	272	216																					
	90 S	469	536	278	231																					
	90 H	507	574	278	231																					
SFM 75	80 M	489	550	298	216	28	120	31,3	8	40	130	165	200	14	13	6	86	205	10	120	26	90	172	153	51	111
	90 S	498	565	304	231																					
	90 H	536	603	304	231																					
	100 H	568	645	325	261																					
SFM 90	80 M	524	585	330	216	35	140	38,3	10	45	180	215	250	14	13	6	103	238	11	140	33	100	206	172	52	111
	90 S	533	600	336	231																					
	90 H	571	638	336	231																					
	100 H	603	680	357	261																					
	112 M	575	670	365	282																					
SM 110	80 M	581	642	375	216	42	155	45,3	12	50	170	230	280	14	15	6	127,5	295	15	170	43	115	253	210	51,5	131
	90 S	590	657	381	231																					
	90 H	628	695	381	231																					
	100 H	660	737	401	261																					
	112 M	632	727	410	282																					
	132 S	689	793	432	325																					
	132 M	730	834	432	325																					
SM 130	90 S	630	697	421	231	45	170	48,8	14	55	180	255	320	16	15	6	147,5	335	16	200	48	120	293	240	51,5	140
	90 H	668	735	421	231																					
	100 H	700	777	441	261																					
	112 M	672	767	450	282																					
	132 S	729	833	472	325																					
	132 M	770	874	472	325																					
SM 150	100 L	752	829	484	261	50	200	53,8	14	65	180	255	320	16	15	6	170	400	18	240	50	145	340	300	51,5	155
	112 M	724	819	492	282																					
	132 S	781	885	514	325																					
	132 M	822	926	514	325																					
	160 M	900	1017	563	400																					
	160 L	945	1062	563	400																					



The worm gear units, IRS series remains one the best solution for simple applications in need of high ratios. This gearbox unit also propose perfect assistance for situation in which backstop needs to be strong and resistant.

*Les réducteurs à vis sans fin de la série IRS restent l'une des meilleures solutions pour les applications simples nécessitant des rapports élevés. Cette boîte de vitesses propose également une assistance parfaite pour les situations dans lesquelles l'antidévireur doit être solide et résistant.*

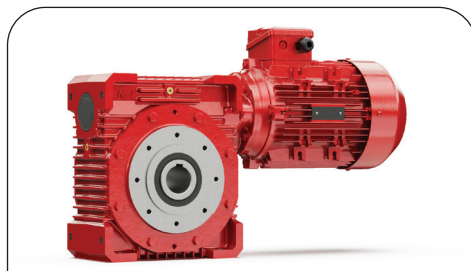
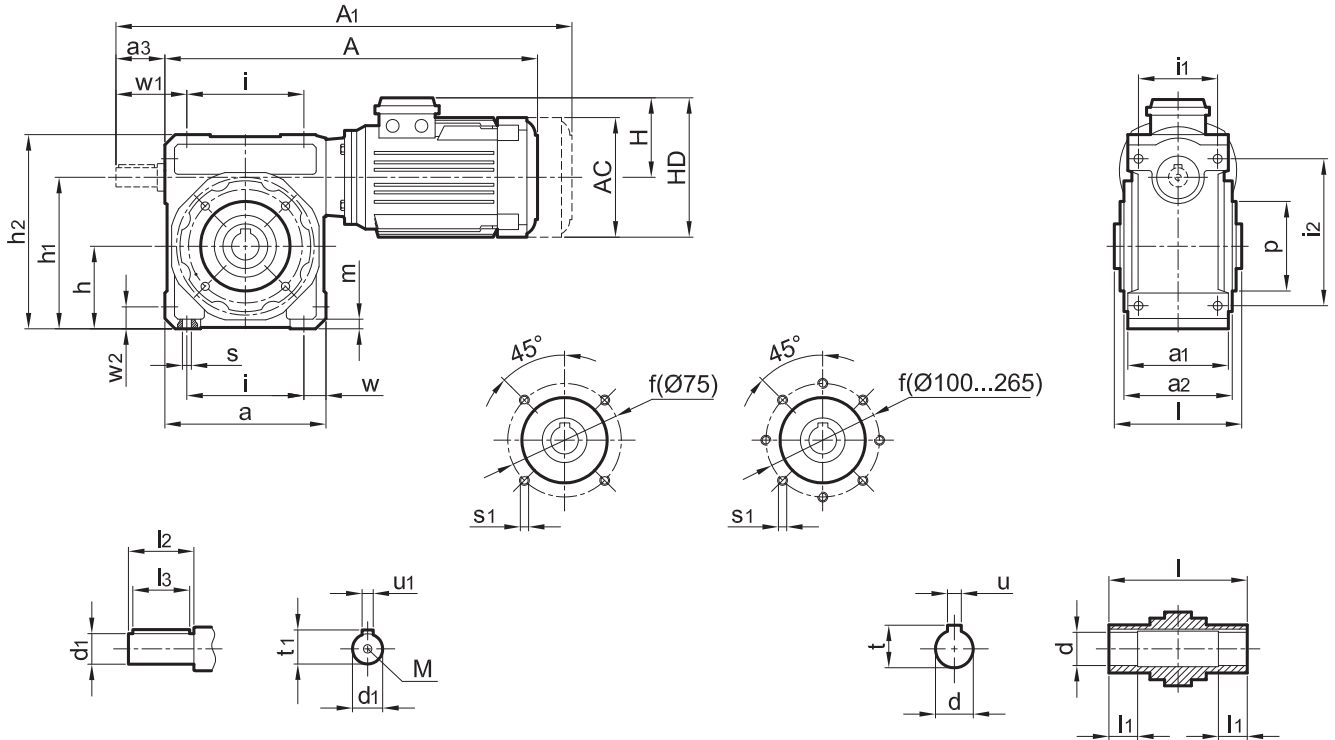

Type Type	Torque (Max) Couple (Max)	Shaft Diameter Diamètre de l'arbre de sortie
IRS-52	240 Nm	Ø 20
IRS-65	415 Nm	Ø 25
IRS-82	825 Nm	Ø 30
IRS-102	1465 Nm	Ø 40
IRS-127	2650 Nm	Ø 50
IRS-162	4820 Nm	Ø 70

**Output Shaft Applications / Spécificités de l'arbre de sortie**

IRSAM Type Gearboxes have solid shaft output.  
*Les motoréducteurs du type IRSAM dispose d'arbre de sortie solides.*

**Range of Ratios / Rapports de réduction**

7,5...111

**Applicable Motor Power / Puissance moteur applicable**

0,12 kW ... 22 kW

**Mounting Positions / Position de montage**

You can choose from Foot and Flange mounting options according to your need.  
*Disponible monté sur pied ou pendulaire, en fonction de vos besoins.*

**Input Options / Options d'entrée**

Worm gear unit [IRSA] Réducteur à vis sans fin

Worm gear unit with (IEC) [IRSAP] Réducteur à vis sans fin avec (IEC)

Worm gear unit with motor [IRSAM] Réducteur à vis sans fin avec moteur

**Brake Types / Types de freins**

24V DC or 220v AC electromagnetic brakes.  
*Freins électromagnétiques 24V DC ou 220V AC.*



Type	Motor	A	A1	H	HD	AC	Ød	l	t	u	l1	Ød1	l2	t1	u1	l3	M	h	h1	h2	Øs	m	i	w	i1	a	Øp	Øf	s1	w1	w2	i2	a1	a2	a3			
IRSAM 52	71 M	380	434	123	194	139																																
	80 M	443	504	136	216	158	20	117	23	6	38	16	30	18	5	25	M5	63	113	152	9	6	79	24	75	126	60	75	M6	61	21	110	95	107	37			
	90 S	452	519	141	231	176																																
IRSAM 65	71 M	412	466	123	194	139																																
	80 M	475	536	136	216	158	24	124	27	8	41	18	35	21	6	25	M6	77	140	185	9	8	105	25	86	155	80	100	M6	66	25	135	106	114	41			
	90 S	484	551	141	231	176																																
IRSAM 82	80 M	515	576	136	216	158																																
	90 S	524	591	141	231	176	30	143	33	8	45	24	50	27	8	38	M8	95	175	230	11	10	125	30	102	185	110	130	M8	88	30	170	125	130	58			
	90 L	562	629	141	231	176																																
	100 L	559	636	161	261	195																																
IRSAM 102	90 L	611	678	141	231	176																																
	100 L	643	720	161	261	195	40	163	43	12	50	28	60	31	8	50	M10	120	220	282	13	14	170	32	115	234	130	165	M10	103	32	218	146	150	71			
	112 M	615	710	170	282	220																																
IRSAM 127	100 L	699	776	161	261	195																																
	112 M	671	766	170	282	220	50	188	54	14	60	30	60	33	8	50	M10	150	275	345	13	16	210	40	135	290	130	165	M10	114	40	265	165	175	74			
	132 S	728	832	193	325	262																																
	132 M	769	873	193	325	262																																
IRSAM 162	132 S	873	977	193	325	262																																
	132 M	914	1018	193	325	262	70	251	75	20	82	45	80	49	14	71	M16	200	360	450	13	25	270	58	175	385	230	265	M12	164	58	335	215	235	90			
	160 M	992	1109	240	400	315																																
	160 L	1037	1154	240	400	315																																

The worm gear units, IRS series remains one the best solution for simple applications in need of high ratios. This gearbox unit also propose perfect assistance for situation in which backstop needs to be strong and resistant.

*Les réducteurs à vis sans fin de la série IRS restent l'une des meilleures solutions pour les applications simples nécessitant des rapports élevés. Cette boîte de vitesses propose également une assistance parfaite pour les situations dans lesquelles l'antidévireur doit être solide et résistant.*

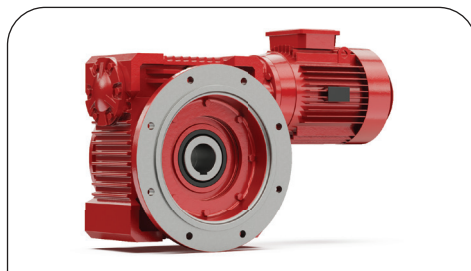
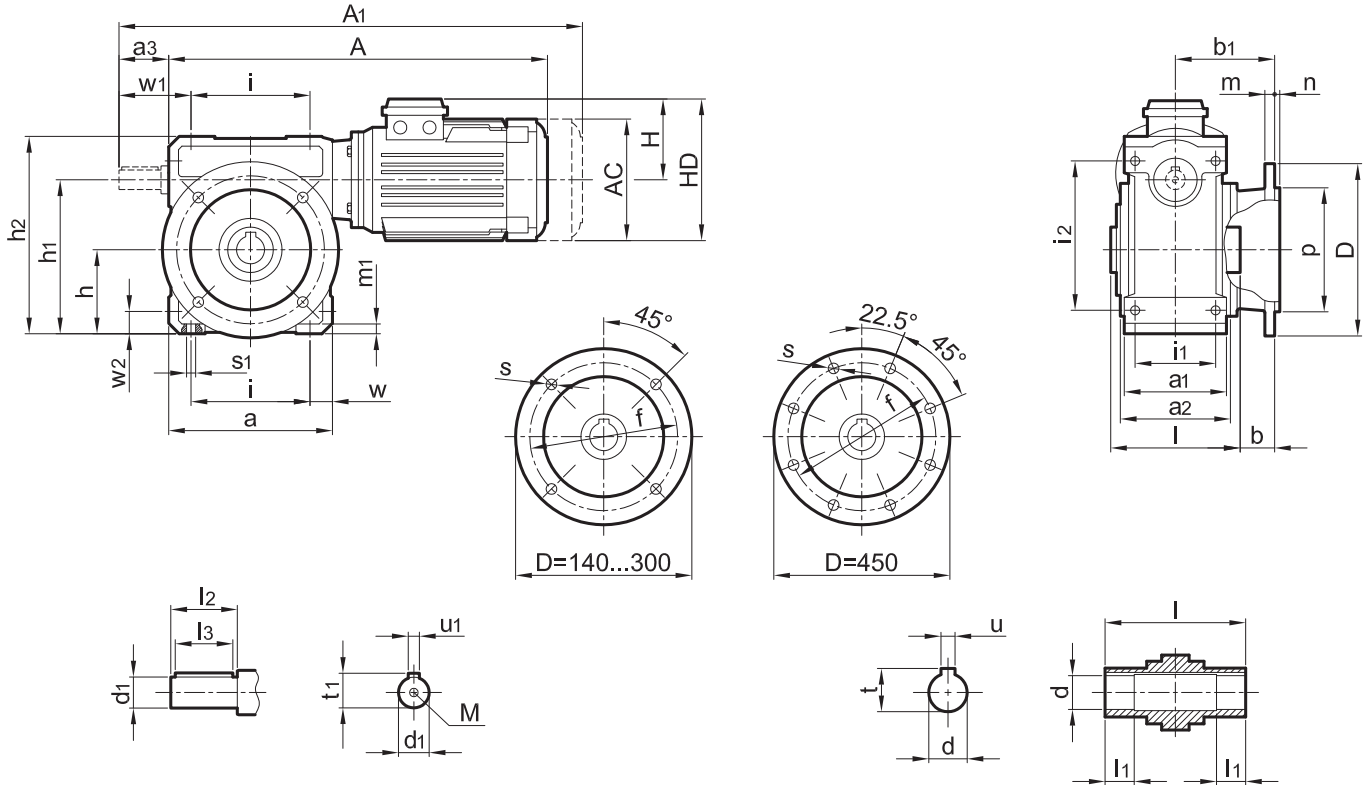

Type Type	Torque (Max) Couple (Max)	Shaft Diameter Diamètre de l'arbre de sortie
IRS-52	240 Nm	Ø 20
IRS-65	415 Nm	Ø 25
IRS-82	825 Nm	Ø 30
IRS-102	1465 Nm	Ø 40
IRS-127	2650 Nm	Ø 50
IRS-162	4820 Nm	Ø 70

**Output Shaft Applications / Spécificités de l'arbre de sortie**

IRSFM Type Gearboxes have solid shaft output.  
*Les motoréducteurs du type IRSFM dispose d'arbre de sortie solides.*

**Range of Ratios / Rapports de réduction**

7,5...111

**Applicable Motor Power / Puissance moteur applicable**

0,12 kW ... 22 kW

**Mounting Positions / Position de montage**

You can choose from Foot and Flange mounting options according to your need.  
*Disponible monté sur pied ou pendulaire, en fonction de vos besoins.*

**Input Options / Options d'entrée**

Worm gear unit [IRSF] Réducteur à vis sans fin

Worm gear unit with (IEC) [IRSFPM] Réducteur à vis sans fin avec (IEC)

Worm gear unit with motor [IRSFM] Réducteur à vis sans fin avec moteur

**Brake Types / Types de freins**

24V DC or 220v AC electromagnetic brakes.  
*Freins électromagnétiques 24V DC ou 220V AC.*



Type	Motor	A	A1	H	HD	AC	Ød	l	t	u	l1	Øp	Øf	ØD	Øs	m	n	Ød1	l2	t1	u1	l3	M	h	h1	h2	Øs1	m1	i	w	i1	a	w1	w2	i2	a1	a2	a3	b	b1											
IRSFM 52	71 M	380	434	123	194	139																																													
	80 M	443	504	136	216	158	20	117	22,8	6	38	95	115	140	9	8	3	16	30	18	5	25	M5	63	113	152	8,5	6	79	23,5	75	126	61	21	110	95	107	37	18	76,5											
	90 S	452	519	141	231	176																																													
IRSFM 65	71 M	412	466	123	194	139																																													
	80 M	475	536	136	216	158	24	124	27,3	8	41	110	130	160	9	10	3,5	18	35	20,5	6	25	M6	77	140	185	9	8	105	25	86	155	66	25	135	106	114	41	36	98											
	90 S	484	551	141	231	176																																													
IRSFM 82	80 M	515	576	136	216	158																																													
	90 S	524	591	141	231	176																																													
	90 L	562	629	141	231	176	30	143	33,3	8	45	130	165	200	12	12	3,5	24	50	27	8	38	M8	95	175	230	11	10	125	30	102	185	88	30	170	125	130	58	43	114,5											
	100 L	559	636	161	261	195																																													
IRSFM 102	90 L	611	678	141	231	176																																													
	100 L	643	720	161	261	195	40	163	43,3	12	50	180	215	250	14	13	4	28	60	31	8	50	M10	120	220	282	13	14	170	32	115	234	103	32	218	146	150	71	52	133,5											
	112 M	615	710	170	282	220																																													
IRSFM 127	100 L	699	776	161	261	195																																													
	112 M	671	766	170	282	220																																													
	132 S	728	832	193	325	262	50	188	53,8	14	60	230	265	300	14	16	4	30	60	33	8	50	M10	150	275	345	13	16	210	40	135	290	114	40	265	165	175	74	42	136											
	132 M	769	873	193	325	262																																													
IRSFM 162	132 S	873	977	193	325	262																																													
	132 M	914	1018	193	325	262																																													
	160 M	992	1109	240	400	315	70	251	74,9	20	82	350	400	450	18	22	5	45	80	48,5	14	71	M16	200	360	450	13	25	270	57,5	175	385	164	57,5	335	215	235	90	59	184,5											
	160 L	1037	1154	240	400	315																																													

The worm gear units, IRS series remains one the best solution for simple applications in need of high ratios. This gearbox unit also propose perfect assistance for situation in which backstop needs to be strong and resistant.

*Les réducteurs à vis sans fin de la série IRS restent l'une des meilleures solutions pour les applications simples nécessitant des rapports élevés. Cette boîte de vitesses propose également une assistance parfaite pour les situations dans lesquelles l'antidévireur doit être solide et résistant.*

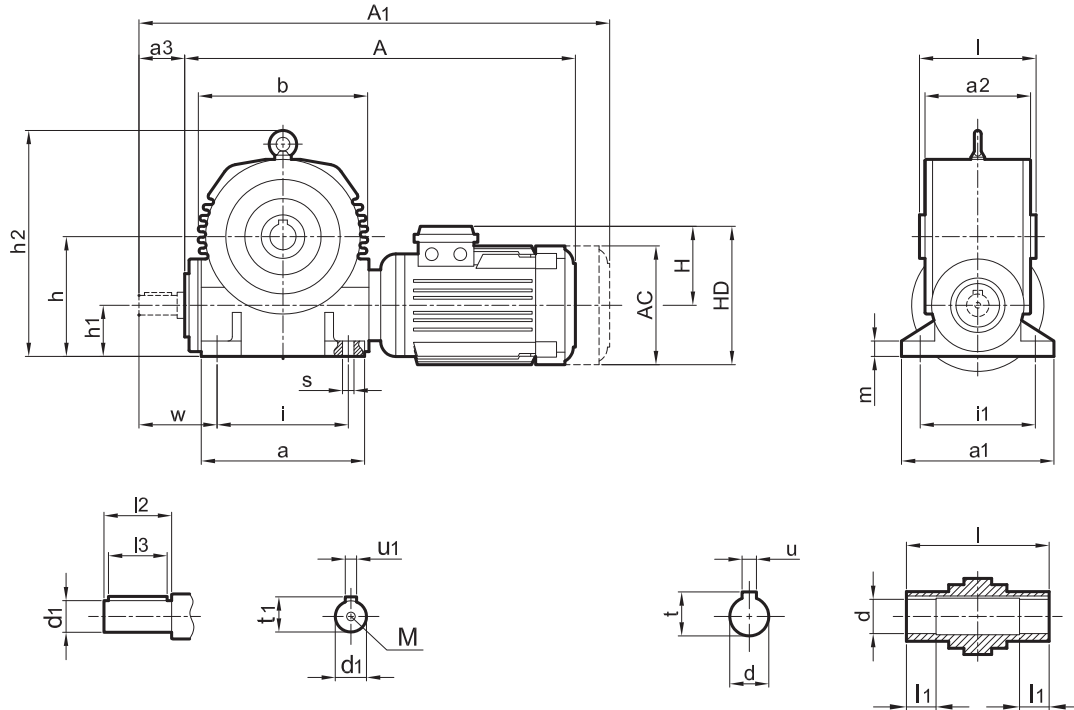

TYPE	Motor	A	A1	H	HD	AC	Ød	l	t	u	l1	Ød1	l2	t1	u1	l3	M	h	h1	h2	Øs	m	i	w	i1	a	a1	a2	a3	b
iRSAM 201	132 S	966	1070	193	325	262																								
	132 M	1007	1111	193	325	262																								
	160 M	1085	1202	240	400	315	80	268	85,4	22	85	55	100	59	16	86	M20	330	130	645	22	40	350	187	295	450	375	262	110	486
	160 L	1130	1247	240	400	315																								
	180 M	1165	1301	260	440	357																								
iRSAM 250	160 L	1210	1327	240	400	315																								
	180 M	1286	1422	260	440	357	90	294	95,4	25	95	60	100	64	18	82	M20	380	130	775	26	55	396	218	352	554	430	292	110	640
	180 L	1286	1422	260	440	357																								

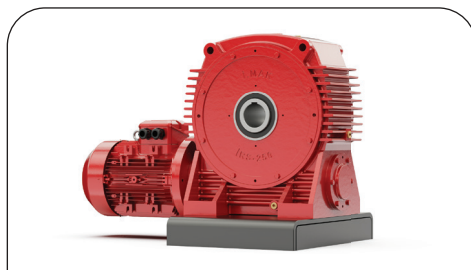

Type Type	Torque (Max) Couple (Max)	Shaft Diameter Diamètre de l'arbre de sortie
IRS-201	7000 Nm	Ø 80
IRS-250	12500 Nm	Ø 90

**Output Shaft Applications / Spécificités de l'arbre de sortie**

iRSAM 201-250 type gearboxes can be used as hollow shaft connected.

*Les réducteurs pendulaires (iRSAM 201-250) peuvent être utilisés avec un arbre de sortie creux.*

**Range of Ratios / Rapports de réduction**

7,5...111

**Applicable Motor Power / Puissance moteur applicable**

0,12 kW ... 22 kW

**Options / Options**

iRSAM 201-250 gearboxes are available with backstop  
*Les réducteurs iRSAM 201-250 sont disponibles avec une option roulement anti-retour.*

The worm gear units, IRS series remains one the best solution for simple applications in need of high ratios. This gearbox unit also propose perfect assistance for situation in which backstop needs to be strong and resistant.

*Les réducteurs à vis sans fin de la série IRS restent l'une des meilleures solutions pour les applications simples nécessitant des rapports élevés. Cette boîte de vitesses propose également une assistance parfaite pour les situations dans lesquelles l'antidévireur doit être solide et résistant.*

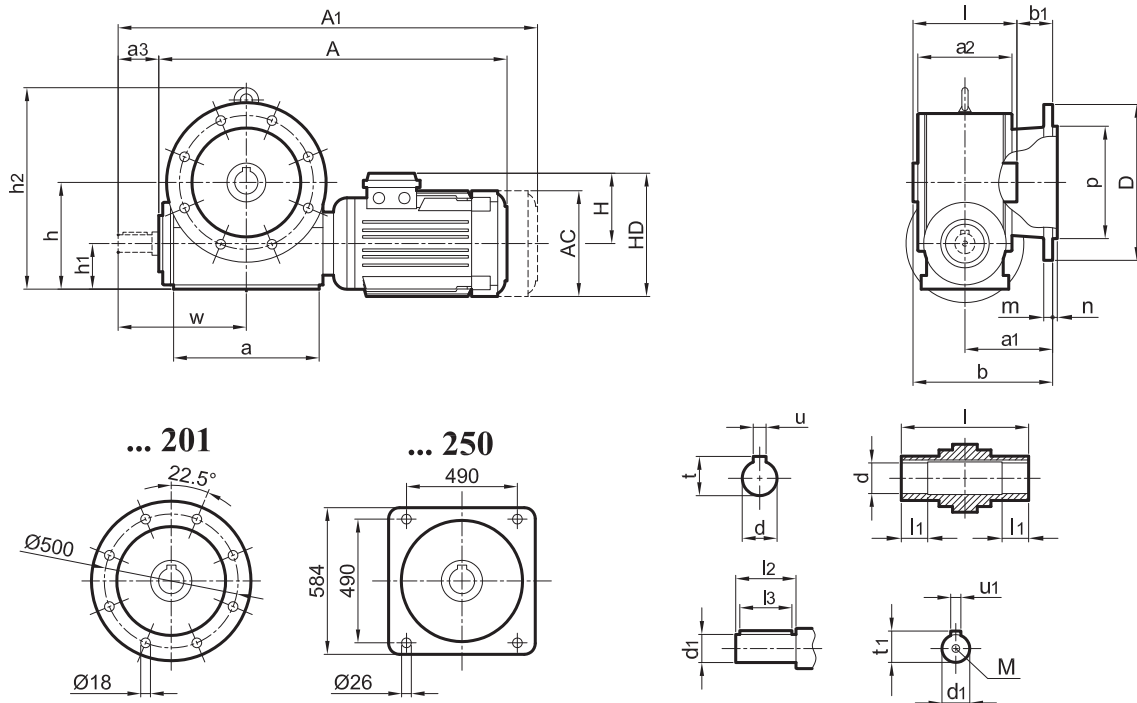

TYPE	Motor	A	A1	H	HD	AC	Ød	l	t	u	l1	Øp	ØD	m	n	Ød1	l2	t1	u1	l3	M	h	h1	h2	w	a	a1	a2	a3	b	b1
IRSFM 201	132 S	966	1070	193	325	262																									
	132 M	1007	1111	193	325	262																									
	160 M	1085	1202	240	400	315	80	268	85	22	85	450	550	25	5	55	100	59	16	86	M20	330	130	645	362	450	209	262	110	343	75
	160 L	1130	1247	240	400	315																									
	180 M	1165	1301	260	440	357																									
IRSFM 250	160 L	1210	1327	240	400	315																									
	180 M	1286	1422	260	440	315	90	294	95,4	25	95	530	-	36	6	60	100	64	18	82	M20	380	130	775	416	554	233	292	110	380	86
	180 L	1286	1422	260	440	357																									

**Output Shaft Applications / Spécificités de l'arbre de sortie**

IRSFM 201-250 type gearboxes can be used as hollow shaft connected.  
*Les réducteurs pendulaires (IRSFM 201-250) peuvent être utilisés avec un arbre de sortie creux.*

**Range of Ratios / Rapports de réduction**

7,5...111

**Applicable Motor Power / Puissance moteur applicable**

0,12 kW ... 22 kW

**Options / Options**

IRSFM 201-250 gearboxes are available with backstop  
*Les réducteurs IRSFM 201-250 sont disponibles avec une option roulement anti-retour.*

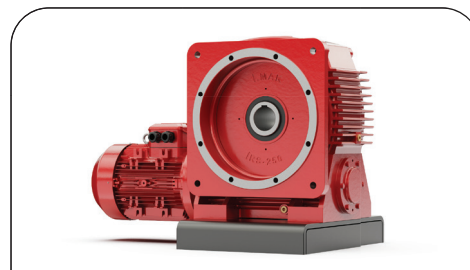

Type	Torque (Max) Couple (Max)	Shaft Diameter Diamètre de l'arbre de sortie
IRS-201	7000 Nm	Ø 80
IRS-250	12500 Nm	Ø 90

The worm gear units, IRSD series remains one the best solution for simple applications in need of high ratios. The design of the gearbox makes it very cost effective. The combination of helical and worm gears offer various options of torque and speed in a reduced housing. With a reduced noise and increased efficiency compared to simple worm gear units, the IRSD Series offers a great solution for various applications.

*Les réducteurs à vis sans fin de la série IRSD combinent un train d'engrenage hélicoïdale à une roue et vis sans fin. Cette combinaison permet d'obtenir un rendement élevé et un fonctionnement silencieux. A la fois compacts et résistants les réducteurs de la série IRSD permettent une économie d'espace et d'énergie pour vos applications et installations. Les réducteurs de la série IRSD sont disponibles dans plus d'une centaine de configurations différentes.*

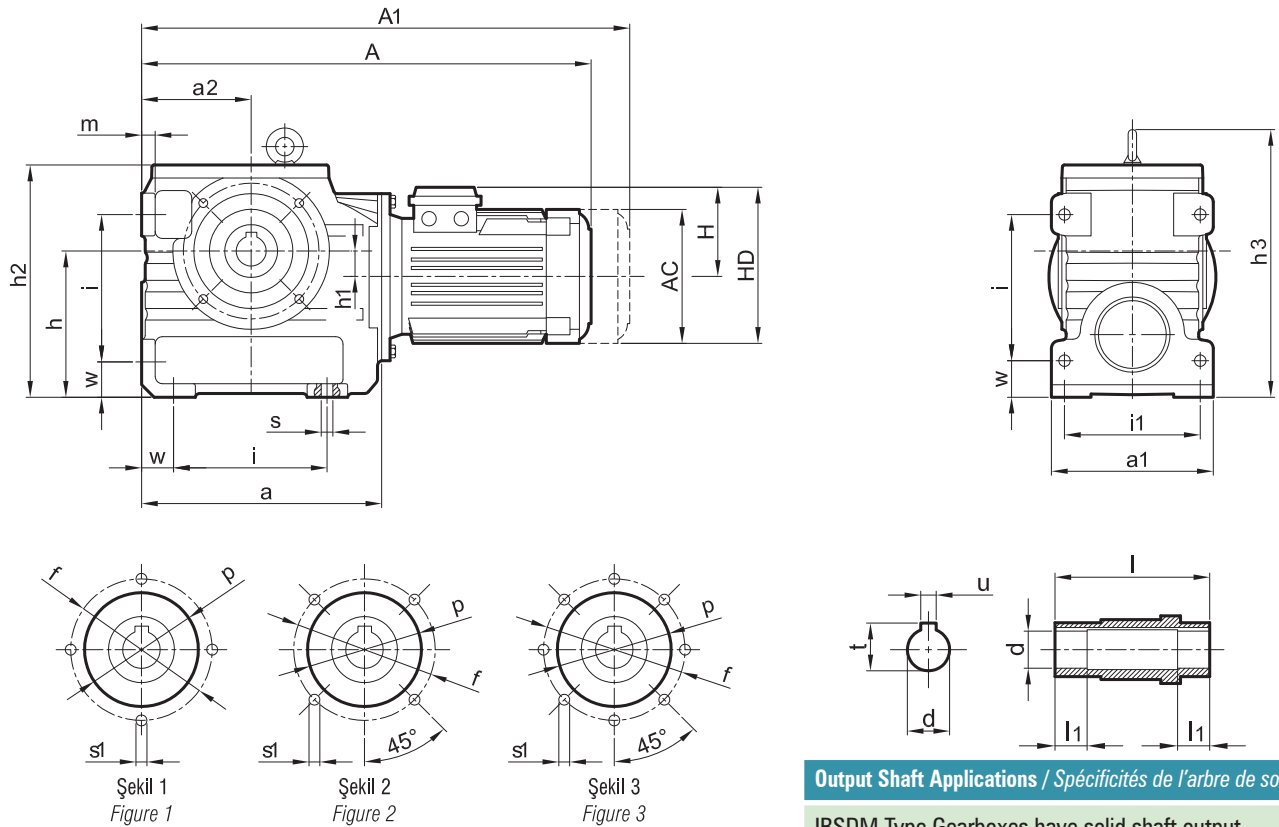

IRSDM Series / Série IRSDM

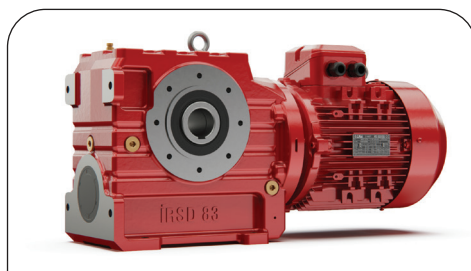

Type Type	Torque (Max) Couple (Max)	Shaft Diameter Diamètre de l'arbre de sortie
IRSD 43	125 Nm	Ø 20
IRSD 53	415 Nm	Ø 25
IRSD 63	825 Nm	Ø 30
IRSD 73	1465 Nm	Ø 40
IRSD 83	2650 Nm	Ø 50
IRSD 161	4820 Nm	Ø 70

**Output Shaft Applications / Spécificités de l'arbre de sortie**

IRSDM Type Gearboxes have solid shaft output.  
*Les motoréducteurs du type IRSDM dispose d'arbre de sortie solides.*

**Range of Ratios / Rapports de réduction**

1/20...1/370

**Applicable Motor Power / Puissance moteur applicable**

0,09 kW ... 11 kW

**Mounting Positions / Position de montage**

You can choose from Foot and Flange mounting options according to your need.  
*Disponible monté sur pied ou pendulaire, en fonction de vos besoins.*

**Input Options / Options d'entrée**

Without motor, with PAM flange [IRSDP]  
*Sans moteur, avec bride PAM*

With motor [IRSDM]  
*Avec moteur*

With motor, with PAM flange [IRSDPM]  
*Avec moteur, avec bride PAM*

**Brake Types / Types de freins**

24V DC or 220v AC electromagnetic brakes.  
*Freins électromagnétiques 24V DC ou 220V AC.*



Type	Motor	A	A1	H	HD	AC	Ød	l	t	u	l1	h	h1	h2	h3	Øs	m	w	i	a	Figure	Øp	Øf	Øs1	i1	a1	a2
IRSDM 43	63 M	409	462,5	108	171	125	20	110	22,8	6	35	95	12	163	189	10	10	25	100	176	1	74	86	M6	85	104	75
	71 M	405	458,5	123	194	139																					
	80 M	476	537	136	216	158																					
	90 S	467	534	141	231	176																					
	90 L	531	598	141	231	176																					
IRSDM 53	71 M	434	487,5	123	194	139	25	135	28,3	8	45	118	17,5	190	225	12	12	30,5	120	205	2	85	100	M8	100	125	96
	80 M	504	565	136	216	158																					
	90 S	496	563	141	231	176																					
	90 L	560	627	141	231	176																					
	100 L	600	677	161	261	195																					
IRSDM 63	71 M	452	505,5	123	194	139	30	150	33,3	8	50	140	25	223	260	12	13	35	140	230	2	110	130	M10	140	155	105
	80 M	524	585	136	216	158																					
	90 S	517	584	141	231	176																					
	90 L	581	648	141	231	176																					
	100 L	620	697	161	261	195																					
	112 M	592	686,5	170	282	220																					
IRSDM 73	71 M	488	541,5	123	194	139	40	184	43,3	12	61	173	33	275	311	14	16	48	160	275	2	130	165	M10	150	178	125
	80 M	561	622	136	216	158																					
	90 S	554	621	141	231	176																					
	90 L	618	685	141	231	176																					
	100 L	659	736	161	261	195																					
	112 M	634	728,5	170	282	220																					
	132 S	705	808,5	193	325	262																					
	132 M	750	853,5	193	325	262																					
IRSDM 83	80 M	631	692	136	216	158	50	220	53,8	14	73	217	40	344	390	14	20	64	215	355	3	130	165	M10	195	225	166
	90 S	622	689	141	231	176																					
	90 L	686	753	141	231	176																					
	100 L	726	803	161	261	195																					
	112 M	700	794,5	170	282	220																					
	132 S	770	874	193	325	262																					
	132 M	815	919	193	325	262																					
	160 M	923	1040	240	400	315																					
IRSDM 161	90 S	794	861	141	231	176	70	305	74,9	20	100	269	70	439	496	20	28	75	250	443	-	-	-	-	230	285	191
	90 L	832	899	141	231	176																					
	100 L	873	950	161	261	195																					
	112 M	845	939,5	170	282	220																					
	132 S	939	1043	193	325	262																					
	132 M	980	1084	193	325	262																					



The worm gear units, IRSD series remains one the best solution for simple applications in need of high ratios. The design of the gearbox makes it very cost effective.

The combination of helical and worm gears offer various options of torque and speed in a reduced housing. With a reduced noise and increased efficiency compared to simple worm gear units, the IRSD Series offers a great solution for various applications.

*Les réducteurs à vis sans fin de la série IRSD combinent un train d'engrenage hélicoïdale à une roue et vis sans fin. Cette combinaison permet d'obtenir un rendement élevé et un fonctionnement silencieux. A la fois compacts et résistants les réducteurs de la série IRSD permettent une économie d'espace et d'énergie pour vos applications et installations. Les réducteurs de la série IRSD sont disponibles dans plus d'une centaine de configurations différentes.*

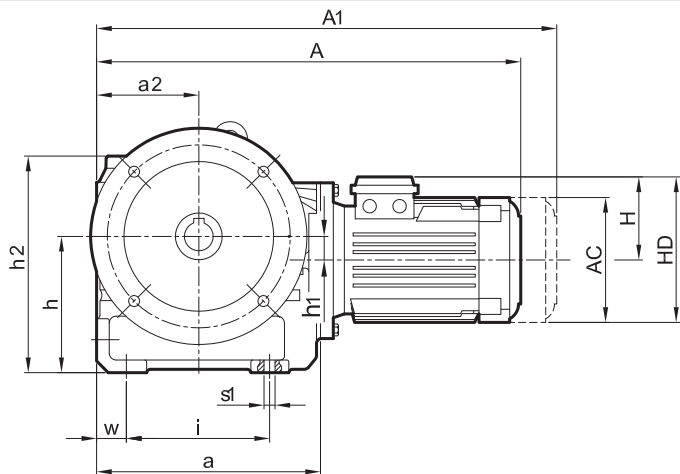

Şekil 1  
Figure 1

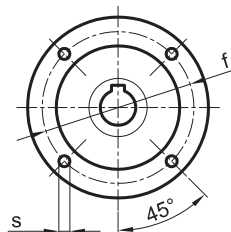

Şekil 2  
Figure 2

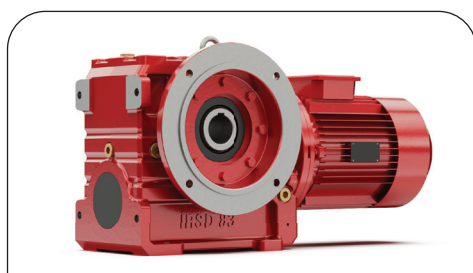
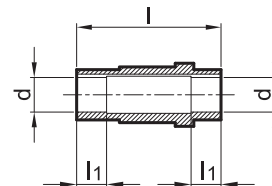
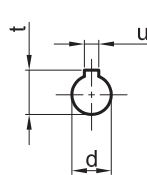
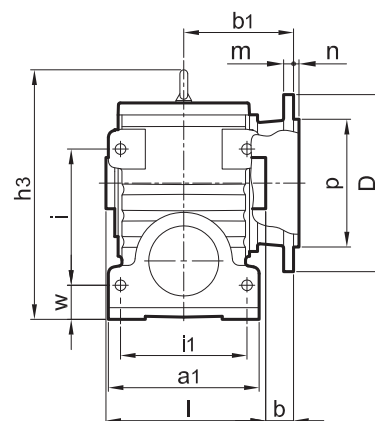

Type Type	Torque (Max) Couple (Max)	Shaft Diameter Diamètre de l'arbre de sortie
IRSD 43	125 Nm	Ø 20
IRSD 53	415 Nm	Ø 25
IRSD 63	825 Nm	Ø 30
IRSD 73	1465 Nm	Ø 40
IRSD 83	2650 Nm	Ø 50
IRSD 161	4820 Nm	Ø 70

**Output Shaft Applications / Spécificités de l'arbre de sortie**

IRSDFM Type Gearboxes have solid shaft output.  
*Les motoréducteurs du type IRSDFM dispose d'arbre de sortie solides.*

**Range of Ratios / Rapports de réduction**

1/20...1/370

**Applicable Motor Power / Puissance moteur applicable**

0,09 kW ... 11 kW

**Mounting Positions / Position de montage**

You can choose from Foot and Flange mounting options according to your need.  
*Disponible monté sur pied ou pendulaire, en fonction de vos besoins.*

**Input Options / Options d'entrée**

Without motor, with PAM flange [IRSDFP]  
*Sans moteur, avec bride PAM*

With motor [IRSDFM]  
*Avec moteur*

With motor, with PAM flange [IRSDFPM]  
*Avec moteur, avec bride PAM*

**Brake Types / Types de freins**

24V DC or 220v AC electromagnetic brakes.  
*Freins électromagnétiques 24V DC ou 220V AC.*



Type	Motor	A	A1	H	HD	AC	Ød	l	t	u	l1	h	h1	h2	h3	Øs1	w	i	i1	a	Øp	Figure	c	Øf	ØD	Øs	m	n	a1	a2	b	b1		
IRSDFM 43	63 M	409	463	108	171	125																												
	71 M	405	459	123	194	139																												
	80 M	476	537	136	216	158	20	110	22,8	6	35	95	12	163	189	10	25	100	85	176	110	1	130	130	160	9	10	3,5	104	75	75	74,5		
	90 S	467	534	141	231	176																												
	90 L	531	598	141	231	176																												
IRSDFM 53	71 M	434	488	123	194	139																												
	80 M	504	565	136	216	158																												
	90 S	496	563	141	231	176	25	135	28,3	8	45	118	18	190	225	12	31	120	100	205	110	2	-	130	160	9	10	3,5	125	96	34	101,5		
	90 L	560	627	141	231	176																												
	100 L	600	677	161	261	195																												
IRSDFM 63	71 M	452	506	123	194	139																												
	80 M	524	585	136	216	158																												
	90 S	517	584	141	231	176	30	150	33,3	8	50	140	25	223	260	12	35	140	130	230	130	2	-	165	200	12	12	3,5	155	105	42	117		
	90 L	581	648	141	231	176																												
	100 L	620	697	161	261	195																												
	112 M	592	687	170	282	220																												
	132 M	705	809	193	325	262																												
IRSDFM 73	71 M	488	542	123	194	139																												
	80 M	561	622	136	216	158																												
	90 S	554	621	141	231	176	40	184	43,3	12	61	173	33	275	311	14	48	160	150	275	180	2	-	215	250	14	13	4	178	125	51	143		
	90 L	618	685	141	231	176																												
	100 L	659	736	161	261	195																												
	112 M	634	729	170	282	220																												
	132 S	705	809	193	325	262																												
	132 M	750	854	193	325	262																												
IRSDFM 83	80 M	631	692	136	216	158																												
	90 S	622	689	141	231	176																												
	90 L	686	753	141	231	176																												
	100 L	726	803	161	261	195	50	220	53,8	14	73	217	40	344	390	14	64	215	195	355	230	2	-	265	300	14	16	4	225	166	41	151		
	112 M	700	795	170	282	220																												
	132 S	770	874	193	325	262																												
	132 M	815	919	193	325	262																												
	160 M	923	1040	240	400	315																												
IRSDFM 161	90 S	794	861	141	231	176																												
	90 L	832	899	141	231	176																												
	100 L	873	950	161	261	195	70	305	74,9	20	100	269	70	439	496	20	75	250	230	443	250	2	-	300	350	19	22	5	285	191	65	218		
	112 M	845	940	170	282	220																												
	132 S	939	1043	193	325	262																												
	132 M	980	1084	193	325	262																												

Discover the new MA/MK Series for heavy applications. Designed to offer higher performance in a compact design, the MA/MK Series is featuring helical and bevel gears.

The new monobloc series is based on a rigid and compact housing to fit on a maximum of applications and environment. The wide range of options and technical features maximize the type of configurations to make it the best solution for every specific field of application. Designed with larger roller bearings and extended center distances the MA/MK can handle higher loads with a longer service life of components.

*Découvrez la nouvelle série MA/MK pour les applications lourdes. Conçue pour offrir des performances supérieures dans un design compact, la série MA/MK comprend des engrenages hélicoïdaux et coniques.*

*La nouvelle série monobloc est basée sur un boîtier rigide et compact pour s'adapter à un maximum d'applications et d'environnement. La large gamme d'options et de caractéristiques techniques maximise le type de configurations pour en faire la meilleure solution pour chaque domaine d'application spécifique.*

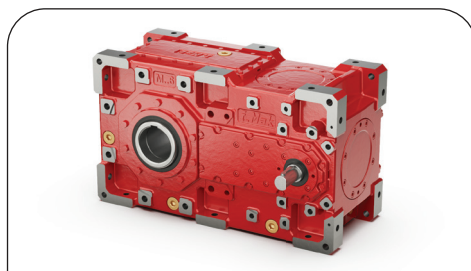
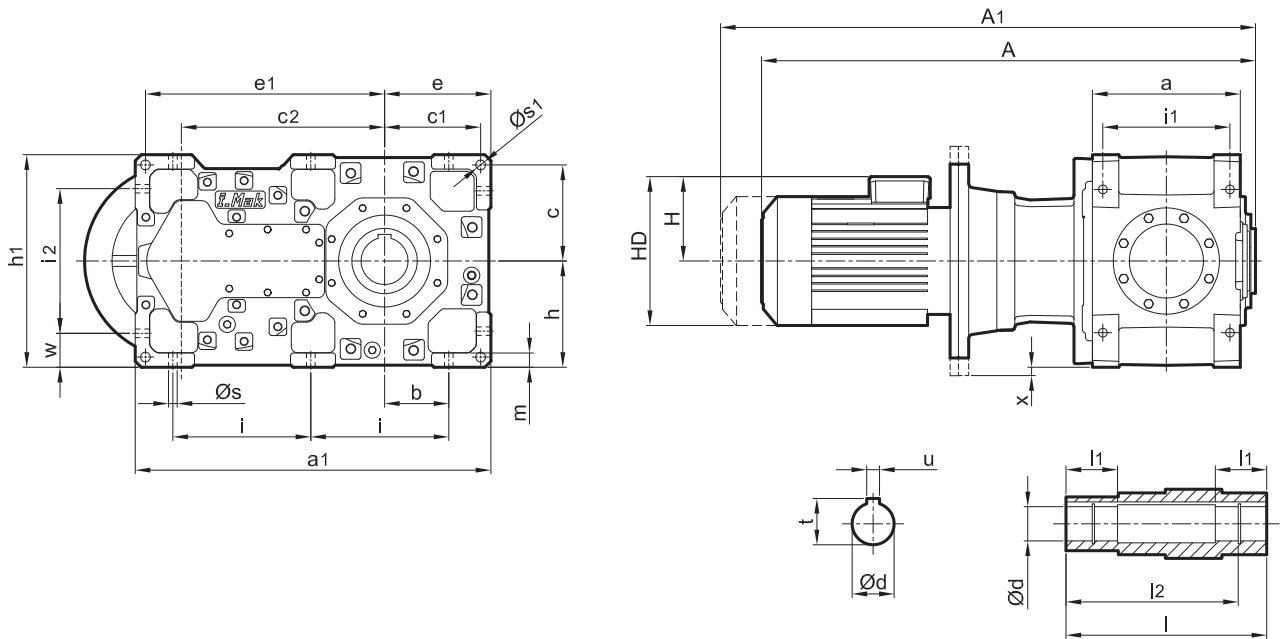

Type Type	Torque (Max) Couple (Max)	Shaft Diameter Diamètre de l'arbre de sortie
MA 402-403	6080 Nm	Ø 80
MA 502-503	10300 Nm	Ø 95
MA 602-603	12900 Nm	Ø 105
MA 702-703	19400 Nm	Ø 115
MA 802-803	24100 Nm	Ø 125
MA 902-903	29930 Nm	Ø 135
MA 1002-1003	36000 Nm	Ø 150
MA 1102-1103	50000 Nm	Ø 165

**Output Shaft Applications / Spécificités de l'arbre de sortie**

MAM 02-03 Type Gearboxes have solid shaft output.  
*Les motoréducteurs du type MAM 02-03 dispose d'arbre de sortie solides.*

**Range of Ratios / Rapports de réduction**

6,028...423,479

**Applicable Motor Power / Puissance moteur applicable**

2,2 kW ... 560 kW

**Mounting Positions / Position de montage**

You can choose from Foot and Flange mounting options according to your need.  
*Disponible monté sur pied ou pendulaire, en fonction de vos besoins.*

**Input Options / Options d'entrée**

Solid input shaft [MA] *Solid input shaft*  
IEC Pam flange [MAP] *IEC Pam flange*  
Integrated coupling flange [MAM] *Integrated coupling flange*

**Brake Types / Types de freins**

24V DC or 220v AC electromagnetic brakes.  
*Freins électromagnétiques 24V DC ou 220V AC.*



Type	Motor	A	A1	x	H	HD	Ød	l	t	u	l1	l2	a	a1	b	c	c1	c2	e	e1	Øs	Øs1	i	i1	i2	h	h1	m	w
MAM 502	IEC 180 L B5	1238	1374	-	260	440	95	385	100,4	25	130	345	320	740	134	192,5	191,5	320	214	503,5	19	19	290	275	310	215	430	30	60
	IEC 200 L B5	1306	1453	-	300	500																							
	IEC 225 S B5	1325	1472	13	313	538																							
	IEC 225 M B5	1385	1532	13	313	538																							
	IEC 250 M B5	1434	1581	60	366	616																							
	IEC 280 S B5	1525	1773	60	398	678																							
	IEC 280 M B5	1525	1773	60	398	678																							
	IEC 315 S B5	-	-	115	518	833																							
	IEC 315 M B5	-	-	115	518	833																							
	IEC 315 L B5	-	-	115	518	833																							
MAM 503	IEC 112 M B5	884	979	-	170	282	95	385	100,4	25	130	345	320	740	134	192,5	191,5	416	214	503,5	19	19	290	275	310	215	430	30	60
	IEC 132 S B5	962	1066	-	193	325																							
	IEC 132 M B5	1002	1106	-	193	325																							
	IEC 160 M B5	1097	1214	-	240	400																							
	IEC 160 L B5	1142	1259	-	240	400																							
	IEC 180 M B5	1219	1355	-	260	440																							
	IEC 180 L B5	1219	1355	-	260	440																							
	IEC 200 L B5	1287	1434	-	300	500																							
	IEC 225 S B5	1306	1453	13	313	538																							
	IEC 225 M B5	1366	1513	13	313	538																							
	IEC 250 M B5	1415	1562	60	366	616																							
	IEC 280 S B5	1527	1775	45	398	678																							
IEC 280 M B5	1527	1775	45	398	678																								
IEC 315 S B5	-	-	100	518	833																								
IEC 315 M B5	-	-	100	518	833																								
IEC 315 L B5	-	-	100	518	833																								
MAM 602	IEC 225 S B5	1327	1474	-	313	538	105	390	111,4	28	130	350	320	786	142	207,5	207	350	230	533	19	19	305	275	310	230	460	30	75
	IEC 225 M B5	1387	1534	-	313	538																							
	IEC 250 M B5	1437	1584	45	366	616																							
	IEC 280 S B5	1527	1775	45	398	678																							
	IEC 280 M B5	1527	1775	45	398	678																							
	IEC 315 S B5	-	-	100	518	833																							
	IEC 315 M B5	-	-	100	518	833																							
	IEC 315 L B5	-	-	100	518	833																							
	IEC 132 S B5	964	1068	-	193	325																							
	IEC 132 M B5	1005	1109	-	193	325																							
IEC 160 M B5	1100	1217	-	240	400																								
IEC 160 L B5	1145	1262	-	240	400																								
IEC 180 M B5	1221	1357	-	260	440																								
IEC 180 L B5	1221	1357	-	260	440																								
IEC 200 L B5	1289	1436	-	300	500																								
IEC 225 S B5	1308	1455	-	313	538																								
IEC 225 M B5	1368	1515	-	313	538																								
IEC 250 M B5	1418	1565	45	366	616																								
IEC 225 M B5	1462	1609	-	313	538																								
IEC 250 M B5	1512	1659	15	366	616																								
IEC 280 S B5	1602	1850	15	398	678																								
IEC 280 M B5	1602	1850	15	398	678																								
IEC 315 S B5	1783	2031	70	518	833																								
IEC 315 M B5	1783	2031	70	518	833																								
IEC 315 L B5	1894	2152	70	518	833																								
MAM 702	IEC 225 M B5	1462	1609	-	313	538	115	435	122,4	32	145	395	365	870	165	235	235	380	260	585	24	24	340	315	340	260	520	35	90
	IEC 250 M B5	1512	1659	15	366	616																							
	IEC 280 S B5	1602	1850	15	398	678																							
	IEC 280 M B5	1602	1850	15	398	678																							
	IEC 315 S B5	1783	2031	70	518	833																							
	IEC 315 M B5	1783	2031	70	518	833																							
	IEC 315 L B5	1894	2152	70	518	833																							

Type	Motor	A	A1	x	H	HD	Ød	l	t	u	l1	l2	a	a1	b	c	c1	c2	e	e1	Øs	Øs1	i	i1	i2	h	h1	m	w
MAM 703	IEC 160 M B5	1167	1284	-	240	400	115	435	122.4	32	145	395	365	870	165	235	235	497	260	585	24	24	340	315	340	260	520	35	90
	IEC 160 L B5	1212	1329	-	240	400																							
	IEC 180 M B5	1288	1424	-	260	440																							
	IEC 180 L B5	1288	1424	-	260	440																							
	IEC 200 L B5	1356	1503	-	300	500																							
	IEC 225 S B5	1375	1522	-	313	538																							
	IEC 225 M B5	1435	1582	-	313	538																							
	IEC 250 M B5	1485	1632	15	366	616																							
	IEC 280 S B5	1575	1823	15	398	678																							
MAM 802	IEC 225 S B5	1404	1551	-	313	538	125	400	132	32	147	400	365	950	190	245	260	430	290	630	24	28	375	315	340	275	550	35	105
	IEC 225 M B5	1464	1611	-	313	538																							
	IEC 250 M B5	1514	1661	0	366	616																							
	IEC 280 S B5	1604	1852	0	398	678																							
	IEC 280 M B5	1604	1852	0	398	678																							
	IEC 315 S B5	1785	2033	55	518	833																							
	IEC 315 M B5	1785	2033	55	518	833																							
	IEC 315 L B5	1896	2154	55	518	833																							
MAM 803	IEC 160 M B5	1169	1286	-	240	400	125	400	132.4	32	147	400	365	950	190	245	260	547	290	630	24	28	375	315	340	275	550	35	105
	IEC 160 L B5	1214	1331	-	240	400																							
	IEC 180 M B5	1290	1426	-	260	440																							
	IEC 180 L B5	1290	1426	-	260	440																							
	IEC 200 L B5	1358	1505	-	300	500																							
	IEC 225 S B5	1377	1524	-	313	538																							
	IEC 225 M B5	1437	1584	-	313	538																							
	IEC 250 M B5	1487	1634	0	366	616																							
	IEC 280 S B5	1577	1825	0	398	678																							
	IEC 280 M B5	1577	1825	0	398	678																							
MAM 902	IEC 280 S B5	1668	1916	-	398	678	135	484	143.4	36	161	438	410	1005	182.5	265	260	450	290	685	28	28	395	355	380	295	590	40	105
	IEC 280 M B5	1668	1916	-	398	678																							
	IEC 315 S B5	1849	2097	35	518	833																							
	IEC 315 M B5	1849	2097	35	518	833																							
	IEC 315 L B5	1960	2218	35	518	833																							
MAM 903	IEC 160 L B5	1292	1409	-	240	400	135	484	143.4	36	161	438	410	1005	182.5	265	260	585	290	685	28	28	395	355	380	295	590	40	105
	IEC 180 M B5	1368	1504	-	260	440																							
	IEC 180 L B5	1368	1504	-	260	440																							
	IEC 200 L B5	1436	1583	-	300	500																							
	IEC 225 S B5	1455	1602	-	313	538																							
	IEC 225 M B5	1515	1662	-	313	538																							
	IEC 250 M B5	1565	1712	-	366	616																							
	IEC 280 S B5	1655	1903	-	398	678																							
	IEC 280 M B5	1655	1903	-	398	678																							
	IEC 315 S B5	1836	2084	35	518	833																							
	IEC 315 M B5	1836	2084	35	518	833																							



Type	Motor	A	A1	x	H	HD	Ød	l	t	u	l1	l2	a	a1	b	c	c1	c2	e	e1	Øs	Øs1	i	i1	i2	h	h1	m	w
<b>MAM 1002</b>	IEC 280 M B5	1670	1918	-	398	678	150	488	158.4	36	162	442	410	1080	205	287.5	282.5	500	315	732.5	28	32	430	355	380	320	640	40	130
	IEC 315 S B5	1851	2099	10	518	833																							
	IEC 315 M B5	1851	2099	10	518	833																							
	IEC 315 L B5	1962	2220	10	518	833																							
<b>MAM 1003</b>	IEC 180 M B5	1370	1506	-	260	440	150	488	158.4	36	162	442	410	1080	205	287.5	282.5	635	315	732.5	28	32	430	355	380	320	640	40	130
	IEC 180 L B5	1370	1506	-	260	440																							
	IEC 200 L B5	1438	1585	-	300	500																							
	IEC 225 S B5	1457	1604	-	313	538																							
	IEC 225 M B5	1517	1664	-	313	538																							
	IEC 250 M B5	1567	1714	-	366	616																							
	IEC 280 S B5	1657	1905	-	398	678																							
	IEC 280 M B5	1657	1905	-	398	678																							
	IEC 315 S B5	1838	2086	10	518	833																							
	IEC 315 M B5	1838	2086	10	518	833																							
IEC 315 L B5	1949	2207	10	518	833																								
<b>MAM 1102</b>	IEC 280 M B5	1736	1984	-	398	678	165	560	174.4	40	186	510	470	1200	225	230	310	545	345	820	35	32	480	410	460	345	690	50	115
	IEC 315 S B5	1917	2165	-	518	833																							
	IEC 315 M B5	2028	2286	-	518	833																							
	IEC 315 L B5	2028	2286	-	518	833																							
<b>MAM 1103</b>	IEC 200 L B5	1525	1672	-	300	500	165	560	174.4	40	186	510	470	1200	225	230	310	700	345	820	35	32	480	410	460	345	690	50	115
	IEC 225 S B5	1544	1691	-	313	538																							
	IEC 225 M B5	1604	1751	-	313	538																							
	IEC 250 M B5	1654	1801	-	366	616																							
	IEC 280 S B5	1744	1992	-	398	678																							
	IEC 280 M B5	1744	1992	-	398	678																							
	IEC 315 S B5	1925	2173	-	518	833																							
	IEC 315 M B5	2036	2294	-	518	833																							
	IEC 315 L B5	2036	2294	-	518	833																							

Discover the new MA/MK Series for heavy applications. Designed to offer higher performance in a compact design, the MA/MK Series is featuring helical and bevel gears.

The new monobloc series is based on a rigid and compact housing to fit on a maximum of applications and environment. The wide range of options and technical features maximize the type of configurations to make it the best solution for every specific field of application. Designed with larger roller bearings and extended center distances the MA/MK can handle higher loads with a longer service life of components.

*Découvrez la nouvelle série MA/MK pour les applications lourdes. Conçue pour offrir des performances supérieures dans un design compact, la série MA/MK comprend des engrenages hélicoïdaux et coniques.*

*La nouvelle série monobloc est basée sur un boîtier rigide et compact pour s'adapter à un maximum d'applications et d'environnement. La large gamme d'options et de caractéristiques techniques maximise le type de configurations pour en faire la meilleure solution pour chaque domaine d'application spécifique.*

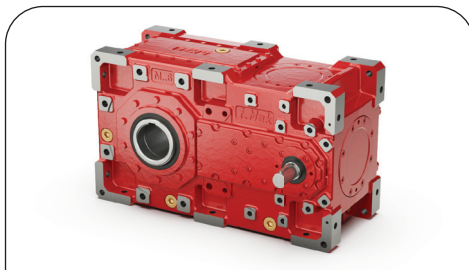
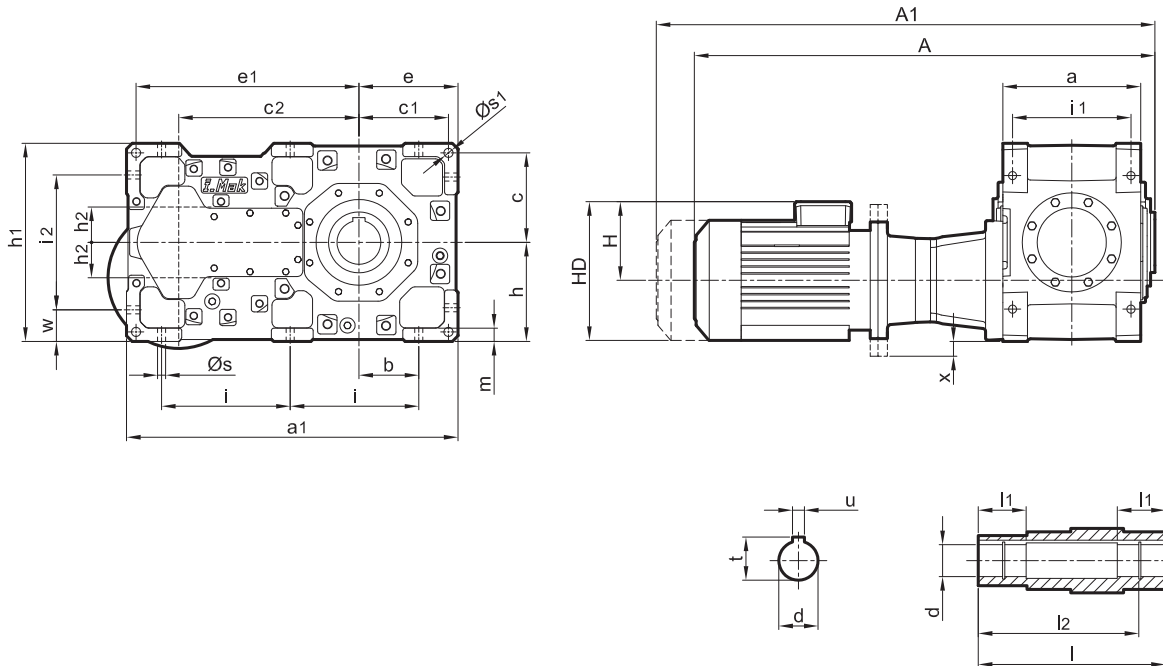

Type Type	Torque (Max) Couple (Max)	Shaft Diameter Diamètre de l'arbre de sortie
MA 704	19400 Nm	Ø 115
MA 804	24100 Nm	Ø 125
MA 904	29930 Nm	Ø 135
MA 1004	36000 Nm	Ø 150
MA 1104	50000 Nm	Ø 165

**Output Shaft Applications / Spécificités de l'arbre de sortie**

MAM 04 Type Gearboxes have solid shaft output.  
*Les motoréducteurs du type MAM 04 dispose d'arbre de sortie solides.*

**Range of Ratios / Rapports de réduction**

6,028...423,479

**Applicable Motor Power / Puissance moteur applicable**

2,2 kW ... 560 kW

**Mounting Positions / Position de montage**

You can choose from Foot and Flange mounting options according to your need.

*Disponible monté sur pied ou pendulaire, en fonction de vos besoins.*

**Input Options / Options d'entrée**

Solid input shaft [MA] *Solid input shaft*

IEC Pam flange [MAP] *IEC Pam flange*

Integrated coupling flange [MAM] *Integrated coupling flange*

**Brake Types / Types de freins**

24V DC or 220v AC electromagnetic brakes.

*Freins électromagnétiques 24V DC ou 220V AC.*



Type	Motor	A	A1	x	H	HD	Ød	l	t	u	l1	l2	a	a1	b	c	c1	c2	e	e1	Øs	Øs1	i	i1	i2	h	h1	h2	m	w
MAM 704	IEC 100 L B5	960	1037	-	161	261																								
	IEC 112 M B5	932	1027	-	170	282																								
	IEC 132 S B5	1009	1113	-	193	325																								
	IEC 132 M B5	1050	1154	-	193	325	115	435	122.4	32	145	395	365	870	165	235	235	497	260	585	24	24	340	315	340	260	520	93	35	90
	IEC 160 M B5	1145	1262	8	240	400																								
	IEC 160 L B5	1190	1307	8	240	400																								
	IEC 180 M B5	1266	1402	12	260	440																								
MAM 804	IEC 100 L B5	962	1039	-	161	261																								
	IEC 112 M B5	934	1029	-	170	282																								
	IEC 132 S B5	1011	1115	-	193	325																								
	IEC 132 M B5	1052	1156	-	193	325	125	400	132.4	32	147	400	365	950	190	245	260	547	290	630	24	28	375	315	340	275	550	93	35	105
	IEC 160 M B5	1147	1264	-	240	400																								
	IEC 160 L B5	1192	1309	-	240	400																								
	IEC 180 M B5	1268	1404	-	260	440																								
IEC 180 L B5	1268	1404	-	260	440																									
MAM 904	IEC 112 M B5	985	1080	-	170	282																								
	IEC 132 S B5	1062	1166	-	193	325																								
	IEC 132 M B5	1103	1207	-	193	325																								
	IEC 160 M B5	1198	1315	-	240	400																								
	IEC 160 L B5	1243	1360	-	240	400	135	484	143.4	36	161	438	410	1005	182.5	265	260	585	290	685	28	28	395	355	380	295	590	95	40	105
	IEC 180 M B5	1319	1455	-	260	440																								
	IEC 180 L B5	1319	1455	-	260	440																								
	IEC 200 L B5	1387	1534	-	300	500																								
	IEC 225 S B5	1406	1553	28	313	538																								
	IEC 225 M B5	1466	1613	28	313	538																								
MAM 1004	IEC 112 M B5	987	1082	-	170	282																								
	IEC 132 S B5	1064	1168	-	193	325																								
	IEC 132 M B5	1105	1209	-	193	325																								
	IEC 160 M B5	1200	1317	-	240	400																								
	IEC 160 L B5	1245	1362	-	240	400	150	488	158.4	36	162	442	410	1080	205	287.5	282.5	635	315	732.5	28	32	430	355	380	320	640	95	40	130
	IEC 180 M B5	1321	1457	-	260	440																								
	IEC 180 L B5	1321	1457	-	260	440																								
	IEC 200 L B5	1389	1536	-	300	500																								
IEC 225 S B5	1408	1555	3	313	538																									
MAM 1104	IEC 132 S B5	1140	1244	-	193	325																								
	IEC 132 M B5	1181	1285	-	193	325																								
	IEC 160 M B5	1278	1395	-	240	400																								
	IEC 160 L B5	1323	1440	-	240	400																								
	IEC 180 M B5	1399	1535	-	260	440																								
	IEC 180 L B5	1399	1535	-	260	440	165	560	174.4	40	186	510	470	1200	225	230	310	700	345	820	35	32	480	410	460	345	690	116	50	115
	IEC 200 L B5	1467	1614	-	300	500																								
	IEC 225 S B5	1486	1633	-	313	538																								
	IEC 225 M B5	1546	1693	-	313	538																								
	IEC 250 M B5	1596	1743	46	366	616																								



Discover the new MA/MK Series for heavy applications. Designed to offer higher performance in a compact design, the MA/MK Series is featuring helical and bevel gears.

The new monobloc series is based on a rigid and compact housing to fit on a maximum of applications and environment. The wide range of options and technical features maximize the type of configurations to make it the best solution for every specific field of application. Designed with larger roller bearings and extended center distances the MA/MK can handle higher loads with a longer service life of components.

*Découvrez la nouvelle série MA/MK pour les applications lourdes. Conçue pour offrir des performances supérieures dans un design compact, la série MA/MK comprend des engrenages hélicoïdaux et coniques.*

*La nouvelle série monobloc est basée sur un boîtier rigide et compact pour s'adapter à un maximum d'applications et d'environnement. La large gamme d'options et de caractéristiques techniques maximise le type de configurations pour en faire la meilleure solution pour chaque domaine d'application spécifique.*

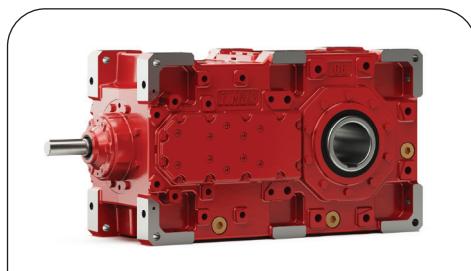
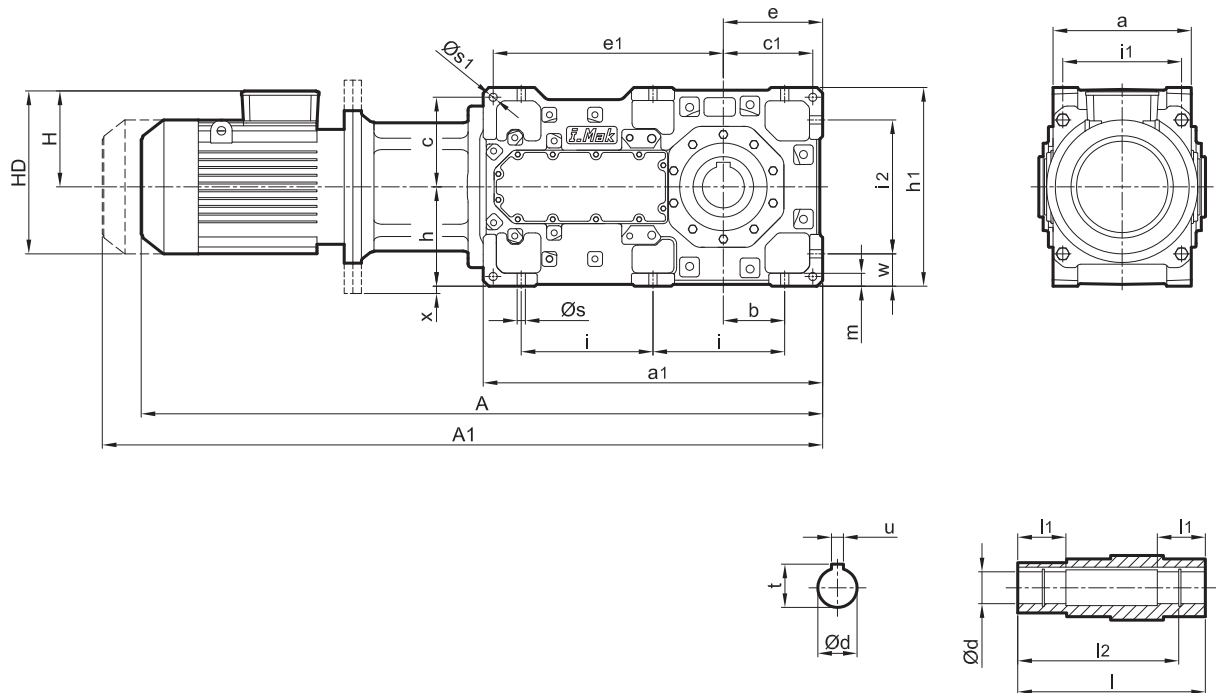

Type Type	Torque (Max) Couple (Max)	Shaft Diameter Diamètre de l'arbre de sortie
MK 403-404	6100 Nm	Ø 80
MK 503-504	10300 Nm	Ø 95
MK 603-604	12900 Nm	Ø 105
MK 703-704	19400 Nm	Ø 115
MK 803-804	22520 Nm	Ø 125
MK 903-904	29530 Nm	Ø 135
MK 1003-1004	37580 Nm	Ø 150
MK 1103-1104	50000 Nm	Ø 165

#### Output Shaft Applications / Spécificités de l'arbre de sortie

MKM 03-04 Type Gearboxes have solid shaft output.  
*Les motoréducteurs du type MKM 03-04 dispose d'arbre de sortie solides.*

#### Range of Ratios / Rapports de réduction

15,674...511,760

#### Applicable Motor Power / Puissance moteur applicable

0,75 kW ... 250 kW

#### Mounting Positions / Position de montage

You can choose from Foot and Flange mounting options according to your need.

*Disponible monté sur pied ou pendulaire, en fonction de vos besoins.*

#### Input Options / Options d'entrée

Solid input shaft [MK] *Solid input shaft*

IEC Pam flange [MKP] *IEC Pam flange*

Integrated coupling flange [MKM] *Integrated coupling flange*

#### Brake Types / Types de freins

24V DC or 220v AC electromagnetic brakes.

*Freins électromagnétiques 24V DC ou 220V AC.*



Type	Motor	A	A1	x	H	HD	Ød	l	t	u	l1	l2	a	a1	b	c	c1	e	e1	Øs	Øs1	i	i1	i2	h	h1	m	w
MKM 503 G09	IEC 112 M B5	1351	1446	-	170	282	95	385	100,4	25	127	345	320	740	134	192,5	191,5	214	503,5	19	19	290	275	310	215	430	30	60
	IEC 132 S B5	1428	1532	-	193	325																						
	IEC 132 M B5	1469	1573	-	193	325																						
	IEC 160 M B5	1577	1694	-	240	400																						
	IEC 160 L B5	1622	1739	-	240	400																						
	IEC 180 M B5	1698	1834	-	260	440																						
	IEC 180 L B5	1698	1834	-	260	440																						
	IEC 200 L B5	1766	1913	-	300	500																						
	IEC 225 S B5	1785	1932	13	313	538																						
	IEC 225 M B5	1845	1992	13	313	538																						
IEC 250 M B5	1895	2042	60	366	616																							
MKM 504 G09	IEC 90 L B5	1322	1389	-	141	231	95	385	100,4	25	127	345	320	740	134	192,5	191,5	214	503,5	19	19	290	275	310	215	430	30	60
	IEC 100 L B5	1379	1456	-	161	261																						
	IEC 112 M B5	1351	1446	-	170	282																						
	IEC 132 S B5	1428	1532	-	193	325																						
	IEC 132 M B5	1469	1573	-	193	325																						
	IEC 160 M B5	1577	1694	-	240	400																						
	IEC 160 L B5	1622	1739	-	240	400																						
MKM 603 G09	IEC 112 M B5	1397	1492	-	170	282	105	390	111,4	28	130	350	320	786	142	207,5	207	230	533	19	19	305	275	310	230	460	30	75
	IEC 132 S B5	1474	1578	-	193	325																						
	IEC 132 M B5	1515	1619	-	193	325																						
	IEC 160 M B5	1623	1740	-	240	400																						
	IEC 160 L B5	1668	1785	-	240	400																						
	IEC 180 M B5	1744	1880	-	260	440																						
	IEC 180 L B5	1744	1880	-	260	440																						
	IEC 200 L B5	1812	1959	-	300	500																						
	IEC 225 S B5	1831	1978	-	313	538																						
	IEC 225 M B5	1891	2038	-	313	538																						
IEC 250 M B5	1941	2088	45	366	616																							
MKM 604 G09	IEC 90 L B5	1368	1435	-	141	231	105	390	111,4	28	130	350	320	786	142	207,5	207	230	533	19	19	305	275	310	230	460	30	75
	IEC 100 L B5	1425	1502	-	161	261																						
	IEC 112 M B5	1397	1492	-	170	282																						
	IEC 132 S B5	1474	1578	-	193	325																						
	IEC 132 M B5	1515	1619	-	193	325																						
	IEC 160 M B5	1623	1740	-	240	400																						
	IEC 160 L B5	1668	1785	-	240	400																						
	IEC 180 M B5	1744	1880	-	260	440																						
MKM 703 G09	IEC 160 L B5	1780	1897	-	240	400	115	435	122,4	32	145	395	365	870	165	235	235	260	585	24	24	340	315	340	260	520	35	90
	IEC 180 M B5	1856	1992	-	260	440																						
	IEC 180 L B5	1856	1992	-	260	440																						
	IEC 200 L B5	1924	2071	-	300	500																						
	IEC 225 S B5	1943	2090	-	313	538																						
	IEC 225 M B5	2003	2150	-	313	538																						
	IEC 250 M B5	2053	2200	15	366	616																						
	IEC 280 S B5	2143	2391	15	398	678																						

Type	Motor	A	A1	x	H	HD	Ød	l	t	u	l1	l2	a	a1	b	c	c1	e	e1	Øs	Øs1	i	i1	i2	h	h1	m	w
MKM 704 G09	IEC 100 L B5	1550	1627	-	161	261	115	435	122,4	32	145	395	365	870	165	235	235	260	585	24	24	340	315	340	260	520	35	90
	IEC 112 M B5	1522	1617	-	170	282																						
	IEC 132 S B5	1599	1703	-	193	325																						
	IEC 132 M B5	1640	1744	-	193	325																						
	IEC 160 M B5	1735	1852	-	240	400																						
	IEC 160 L B5	1780	1897	-	240	400																						
	IEC 180 M B5	1856	1992	-	260	440																						
	IEC 180 L B5	1856	1992	-	260	440																						
	IEC 200 L B5	1924	2071	-	300	500																						
MKM 803 G09	IEC 160 L B5	1840	1957	-	240	400	125	400	132,4	32	147	400	365	950	190	245	260	290	630	24	28	375	315	340	275	550	35	105
	IEC 180 M B5	1916	2052	-	260	440																						
	IEC 180 L B5	1916	2052	-	260	440																						
	IEC 200 L B5	1984	2131	-	300	500																						
	IEC 225 S B5	2003	2150	-	313	538																						
	IEC 225 M B5	2063	2210	-	313	538																						
	IEC 250 M B5	2113	2260	0	366	616																						
	IEC 280 S B5	2203	2451	0	398	678																						
	IEC 280 M B5	2203	2451	0	398	678																						
MKM 804 G09	IEC 100 L B5	1610	1687	-	161	261	125	400	132,4	32	147	400	365	950	190	245	260	290	630	24	28	375	315	340	275	550	35	105
	IEC 112 M B5	1582	1677	-	170	282																						
	IEC 132 S B5	1659	1763	-	193	325																						
	IEC 132 M B5	1700	1804	-	193	325																						
	IEC 160 M B5	1795	1912	-	240	400																						
	IEC 160 L B5	1840	1957	-	240	400																						
	IEC 180 M B5	1916	2052	-	260	440																						
	IEC 180 L B5	1916	2052	-	260	440																						
	IEC 200 L B5	1984	2131	-	300	500																						
IEC 225 S B5	2003	2150	-	313	538																							
MKM 903 G09	IEC 180 M B5	2021	2157	-	260	440	135	484	143,4	36	161	438	410	1005	182,5	265	260	290	685	28	28	395	355	380	295	590	40	105
	IEC 180 L B5	2021	2157	-	260	440																						
	IEC 200 L B5	2089	2236	-	300	500																						
	IEC 225 S B5	2108	2255	-	313	538																						
	IEC 225 M B5	2168	2315	-	313	538																						
	IEC 250 M B5	2218	2365	-	366	616																						
	IEC 280 S B5	2308	2556	-	398	678																						
	IEC 280 M B5	2308	2556	-	398	678																						
	IEC 315 S B5	2489	2737	35	518	833																						
IEC 315 M B5	2489	2737	35	518	833																							
MKM 904 G09	IEC 112 M B5	1672	1767	-	170	282	135	484	143,4	36	161	438	410	1005	182,5	265	260	290	685	28	28	395	355	380	295	590	40	105
	IEC 132 S B5	1749	1853	-	193	325																						
	IEC 132 M B5	1790	1894	-	193	325																						
	IEC 160 M B5	1900	2017	-	240	400																						
	IEC 160 L B5	1945	2062	-	240	400																						
	IEC 180 M B5	2021	2157	-	260	440																						
	IEC 180 L B5	2021	2157	-	260	440																						
	IEC 200 L B5	2089	2236	-	300	500																						
	IEC 225 S B5	2108	2255	-	313	538																						
	IEC 225 M B5	2168	2315	-	313	538																						



Type	Motor	A	A1	x	H	HD	Ød	l	t	u	l1	l2	a	a1	b	c	c1	e	e1	Øs	Øs1	i	i1	i2	h	h1	m	w
MKM 1003 G09	IEC 180 L B5	2091	2227	-	260	440	150	488	158,4	36	162	442	410	1080	205	287,5	282,5	315	732,5	28	32	430	355	380	320	640	40	130
	IEC 200 L B5	2159	2306	-	300	500																						
	IEC 225 S B5	2178	2325	-	313	538																						
	IEC 225 M B5	2238	2385	-	313	538																						
	IEC 250 M B5	2288	2435	-	366	616																						
	IEC 280 S B5	2378	2626	-	398	678																						
	IEC 280 M B5	2378	2626	-	398	678																						
	IEC 315 S B5	2559	2807	10	518	833																						
	IEC 315 M B5	2559	2807	10	518	833																						
MKM 1004 G09	IEC 112 M B5	1742	1837	-	170	282	150	488	158,4	36	162	442	410	1080	205	287,5	282,5	315	732,5	28	32	430	355	380	320	640	40	130
	IEC 132 S B5	1819	1923	-	193	325																						
	IEC 132 M B5	1860	1964	-	193	325																						
	IEC 160 M B5	1970	2087	-	240	400																						
	IEC 160 L B5	2015	2132	-	240	400																						
	IEC 180 M B5	2091	2227	-	260	440																						
	IEC 180 L B5	2091	2227	-	260	440																						
	IEC 200 L B5	2159	2306	-	300	500																						
	IEC 225 S B5	2178	2325	-	313	538																						
	IEC 225 M B5	2238	2385	-	313	538																						
MKM 1103 G09	IEC 200 L B5	2306	2453	-	300	500	165	560	174,4	40	186	510	470	1200	225	310	310	345	820	35	32	480	410	460	345	690	50	115
	IEC 225 S B5	2325	2472	-	313	538																						
	IEC 225 M B5	2385	2532	-	313	538																						
	IEC 250 M B5	2435	2582	-	366	616																						
	IEC 280 S B5	2525	2773	-	398	678																						
	IEC 280 M B5	2525	2773	-	398	678																						
	IEC 315 S B5	2706	2954	-	518	833																						
	IEC 315 M B5	2817	3075	-	518	833																						
	IEC 315 L B5	2817	3075	-	518	833																						
	MKM 1104 G09	IEC 160 M B5	2117	2234	-	240																						
IEC 160 L B5		2162	2279	-	240	400																						
IEC 180 M B5		2238	2374	-	260	440																						
IEC 180 L B5		2238	2374	-	260	440																						
IEC 200 L B5		2306	2453	-	300	500																						
IEC 225 S B5		2325	2472	-	313	538																						
IEC 225 M B5		2385	2532	-	313	538																						
IEC 250 M B5		2435	2582	-	366	616																						
IEC 280 S B5		2525	2773	-	398	678																						
IEC 280 M B5		2525	2773	-	398	678																						

Discover the new MA/MK Series for heavy applications. Designed to offer higher performance in a compact design, the MA/MK Series is featuring helical and bevel gears.

The new monobloc series is based on a rigid and compact housing to fit on a maximum of applications and environment. The wide range of options and technical features maximize the type of configurations to make it the best solution for every specific field of application. Designed with larger roller bearings and extended center distances the MA/MK can handle higher loads with a longer service life of components.

*Découvrez la nouvelle série MA/MK pour les applications lourdes. Conçue pour offrir des performances supérieures dans un design compact, la série MA/MK comprend des engrenages hélicoïdaux et coniques.*

*La nouvelle série monobloc est basée sur un boîtier rigide et compact pour s'adapter à un maximum d'applications et d'environnement. La large gamme d'options et de caractéristiques techniques maximise le type de configurations pour en faire la meilleure solution pour chaque domaine d'application spécifique.*

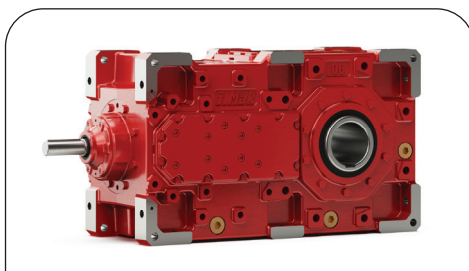
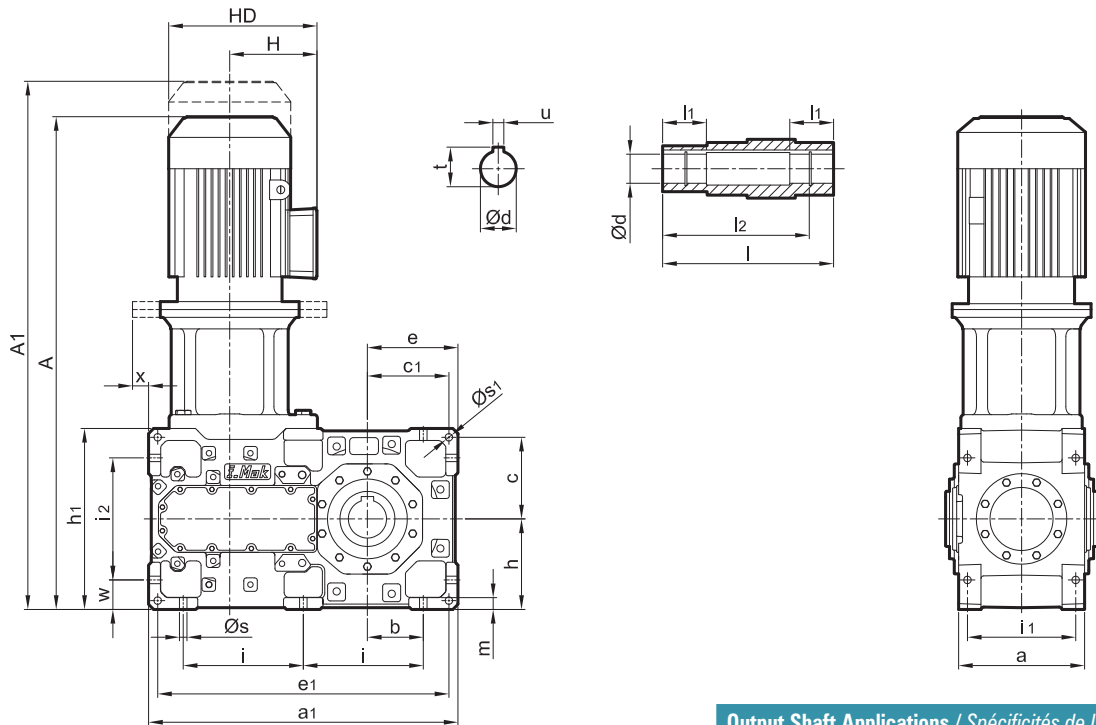

Type Type	Torque (Max) Couple (Max)	Shaft Diameter Diamètre de l'arbre de sortie
MKM 403	5750 Nm	Ø80
MKM 503	10300 Nm	Ø95
MKM 603	12900 Nm	Ø105
MKM 703	19400 Nm	Ø115
MKM 803	22300 Nm	Ø125
MKM 903	29530 Nm	Ø135
MKM 1003	36700 Nm	Ø150
MKM 1103	50000 Nm	Ø165

**Output Shaft Applications / Spécificités de l'arbre de sortie**

MKM 03 Type Gearboxes have solid shaft output.  
*Les motoréducteurs du type MKM 03 dispose d'arbre de sortie solides.*

**Range of Ratios / Rapports de réduction**

14,012 .... 115,380

**Applicable Motor Power / Puissance moteur applicable**

2,2 kW .... 250 kW

**Mounting Positions / Position de montage**

You can choose from Foot and Flange mounting options according to your need.  
*Disponible monté sur pied ou pendulaire, en fonction de vos besoins.*

**Input Options / Options d'entrée**

Solid input shaft [MK] *Solid input shaft*  
IEC Pam flange [MKP] *IEC Pam flange*  
Integrated coupling flange [MKM] *Integrated coupling flange*

**Brake Types / Types de freins**

24V DC or 220v AC electromagnetic brakes.  
*Freins électromagnétiques 24V DC ou 220V AC.*

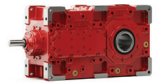

TYPE	Motor	A	A1	x	H	HD	Ød	l	t	u	l1	l2	a	a1	b	c	c1	e	e1	Øs	Øs1	i	i1	i2	h	h1	m	w			
MKM 503 G10	IEC 112 M B5	1032	1127	-	170	282																									
	IEC 132 S B5	1109	1213	-	193	325																									
	IEC 132 M B5	1150	1254	-	193	325																									
	IEC 160 M B5	1258	1375	-	240	400																									
	IEC 160 L B5	1303	1420	-	240	400																									
	IEC 180 M B5	1379	1515	-	260	440	95	385	100,4	25	127	345	320	740	134	192,5	191,5	214	503,5	19	19	290	275	310	215	430	30	60			
	IEC 180 L B5	1379	1515	-	260	440																									
	IEC 200 L B5	1447	1594	-	300	500																									
	IEC 225 S B5	1466	1613	22	313	538																									
	IEC 225 M B5	1526	1673	22	313	538																									
	IEC 250 M B5	1576	1723	69	366	616																									
MKM 603 G10	IEC 112 M B5	1047	1142	-	170	282																									
	IEC 132 S B5	1124	1228	-	193	325																									
	IEC 132 M B5	1165	1269	-	193	325																									
	IEC 160 M B5	1273	1390	-	240	400																									
	IEC 160 L B5	1318	1435	-	240	400																									
	IEC 180 M B5	1394	1530	-	260	440	105	390	111,4	28	130	350	320	786	142	207,5	207	230	533	19	19	305	275	310	230	460	30	75			
	IEC 180 L B5	1394	1530	-	260	440																									
	IEC 200 L B5	1462	1609	-	300	500																									
	IEC 225 S B5	1481	1628	22	313	538																									
	IEC 225 M B5	1541	1688	22	313	538																									
	IEC 250 M B5	1591	1738	69	366	616																									
MKM 703 G10	IEC 160 L B5	1400	1517	-	240	400																									
	IEC 180 M B5	1476	1612	-	260	440																									
	IEC 180 L B5	1476	1612	-	260	440																									
	IEC 200 L B5	1544	1691	-	300	500																									
	IEC 225 S B5	1563	1710	-	313	538	115	435	122,4	32	145	395	365	870	165	235	235	260	585	24	24	340	315	340	260	520	35	90			
	IEC 225 M B5	1623	1770	-	313	538																									
	IEC 250 M B5	1673	1820	45	366	616																									
	IEC 280 S B5	1763	2011	45	398	678																									
MKM 803 G10	IEC 160 L B5	1415	1532	-	240	400																									
	IEC 180 M B5	1491	1627	-	260	440																									
	IEC 180 L B5	1491	1627	-	260	440																									
	IEC 200 L B5	1559	1706	-	300	500																									
	IEC 225 S B5	1578	1725	-	313	538	125	400	132,4	32	147	400	365	950	190	245	260	290	630	24	28	375	315	340	275	550	35	105			
	IEC 225 M B5	1638	1785	-	313	538																									
	IEC 250 M B5	1688	1835	45	366	616																									
	IEC 280 S B5	1778	2026	45	398	678																									
	IEC 280 M B5	1778	2026	45	398	678																									
MKM 903 G10	IEC 180 M B5	1571	1707	-	260	440																									
	IEC 180 L B5	1571	1707	-	260	440																									
	IEC 200 L B5	1639	1786	-	300	500																									
	IEC 225 S B5	1658	1805	-	313	538																									
	IEC 225 M B5	1718	1865	-	313	538	135	484	143,4	36	161	438	410	1005	182,5	265	260	290	685	28	28	395	355	380	295	590	40	105			
	IEC 250 M B5	1768	1915	10	366	616																									
	IEC 280 S B5	1858	2106	10	398	678																									
	IEC 280 M B5	1858	2106	10	398	678																									
	IEC 315 S B5	2039	2287	65	518	833																									
	IEC 315 M B5	2039	2287	65	518	833																									

TYPE	Motor	A	A1	x	H	HD	Ød	l	t	u	l1	l2	a	a1	b	c	c1	e	e1	Øs	Øs1	i	i1	i2	h	h1	m	w			
<b>MKM 1003 G10</b>	IEC 180 L B5	1596	1732	-	260	440																									
	IEC 200 L B5	1664	1811	-	300	500																									
	IEC 225 S B5	1683	1830	-	313	538																									
	IEC 225 M B5	1743	1890	-	313	538																									
	IEC 250 M B5	1793	1940	10	366	616	150	488	158,4	36	162	442	410	1080	205	287,5	282,5	315	732,5	28	32	430	355	380	320	640	40	130			
	IEC 280 S B5	1883	2131	10	398	678																									
	IEC 280 M B5	1883	2131	10	398	678																									
	IEC 315 S B5	2064	2312	65	518	833																									
	IEC 315 M B5	2064	2312	65	518	833																									
<b>MKM 1103 G10</b>	IEC 200 L B5	1761	1908	-	300	500																									
	IEC 225 S B5	1780	1927	-	313	538																									
	IEC 225 M B5	1840	1987	-	313	538																									
	IEC 250 M B5	1890	2037	-	366	616																									
	IEC 280 S B5	1980	2228	-	398	678	165	560	174,4	40	186	510	470	1200	225	310	310	345	820	35	32	480	410	460	345	690	50	115			
	IEC 280 M B5	1980	2228	-	398	678																									
	IEC 315 S B5	2161	2409	20	518	833																									
	IEC 315 M B5	2272	2530	20	518	833																									
	IEC 315 L B5	2272	2530	20	518	833																									

Designed for agitators, mixers and aerators, the special 4DSM are the best solutions for your heavy and complex applications. Available in three sizes of housings, the 4DSM are featuring several different configurations to adapt and fit in many conditions.

Conçus pour les agitateurs, les mélangeurs et les aérateurs, les 4DSM spéciaux sont les meilleures solutions pour vos applications lourdes et complexes. Disponibles en trois tailles de boîtiers, les 4DSM présentent plusieurs configurations différentes pour s'adapter et s'adapter dans de nombreuses conditions.

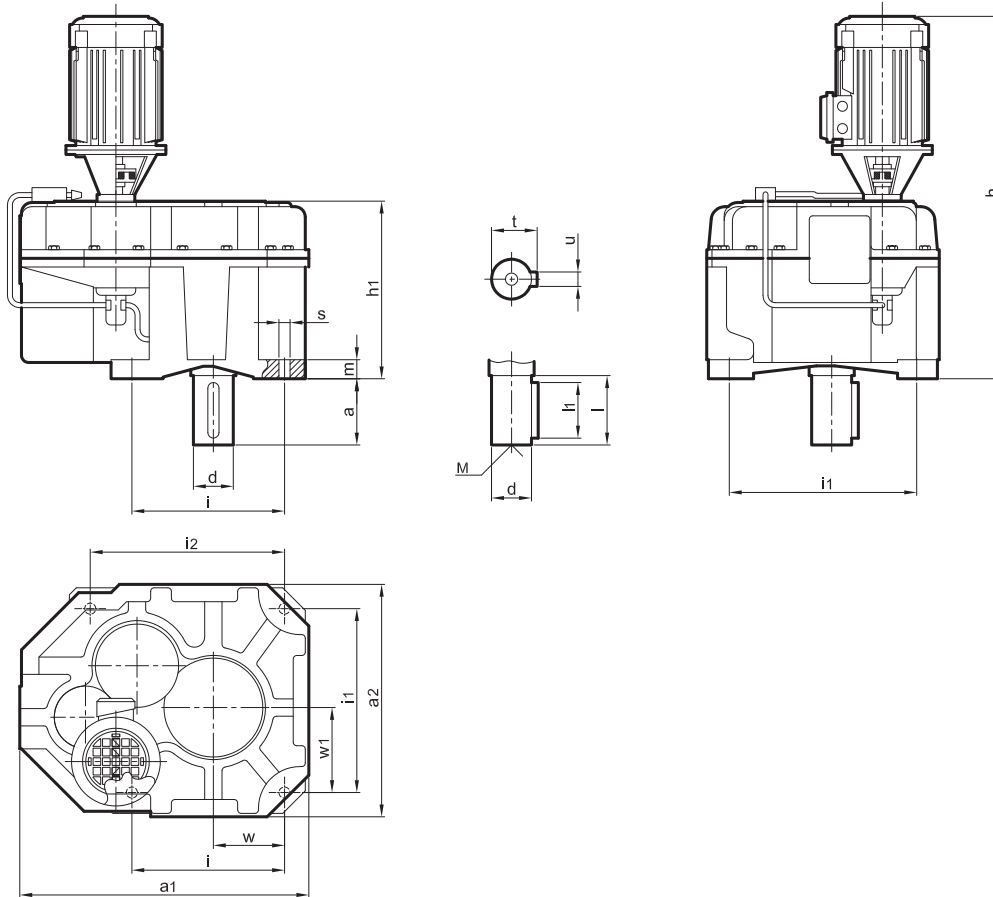

TYPE	Ød	l	t	u	l1	M	h	h1	Øs	m	i	i1	i2	w	w1	a	a1	a2
4DSM 480	105	180	111	28	155	M24	1280	456	26	50	384	440	434	180	210	174	680	540
4DSM 615	115	200	122	32	177	M24	1415	532	32	55	440	555	560	190	252	191	833	670
4DSM 750	125	220	132	32	190	M24	1360	580	38	60	535	650	690	260	255	216	980	800

**Output Shaft Applications / Spécificités de l'arbre de sortie**

4DSM type gearboxes have solid shaft output.  
Les motoréducteurs du type 4DSM dispose d'arbre de sortie solides.

**Range of Ratios / Rapports de réduction**

10 ... 180

**Applicable Motor Power / Puissance moteur applicable**

1,5 kW ... 90 kW

**Options / Options**

4DSM type gearboxes are foot mounted at vertical position.

Les réducteurs de type 4DSM sont montés sur pied en position verticale

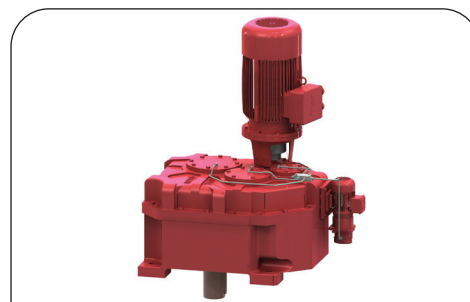

Type	Torque (Max) Couple (Max)	Shaft Diameter Diamètre de l'arbre de sortie
4DSM 480	10500 Nm	Ø 105
4DSM 615	22800 Nm	Ø 115
4DSM 750	28500 Nm	Ø 125



Designed for heavy industrial duties, the A / AE series present the advantages of being perfectly adapted to hard environment and tasks. The gears are designed to help the prevention of noise and vibrations during long and hard operations.

*Conçue pour les applications industrielles lourdes, la série A / AE présente les avantages d'être parfaitement adaptée à l'environnement et aux tâches difficiles. Les engrenages sont conçus pour aider à prévenir le bruit et les vibrations lors d'opérations longues et difficiles.*

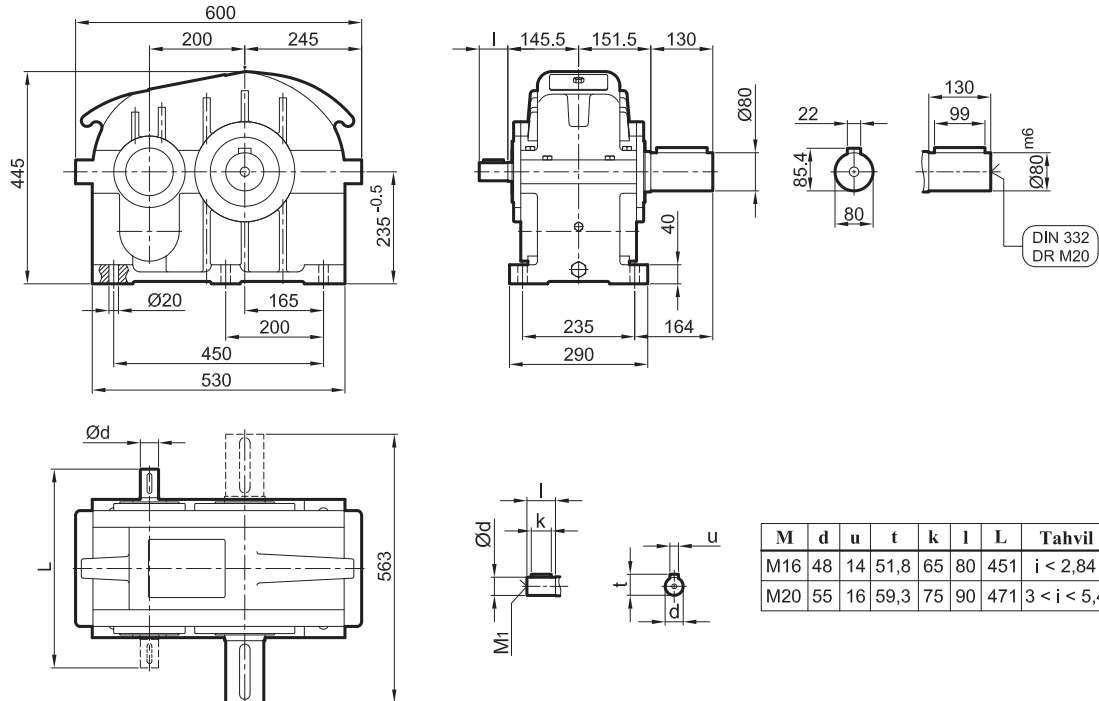

M	d	u	t	k	l	L	Tahvil
<b>M16</b>	48	14	51,8	65	80	451	$i \leq 2,84$
<b>M20</b>	55	16	59,3	75	90	471	$3 < i \leq 5,4$

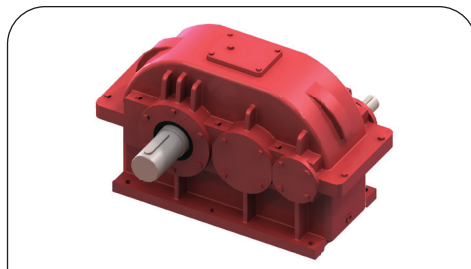

Type <i>Type</i>	Torque (Max) <i>Couple (Max)</i>	Shaft Diameter <i>Diamètre de l'arbre de sortie</i>
A 200	6200 Nm	Ø 80

**Output Shaft Applications / Spécificités de l'arbre de sortie**

A type gearboxes have solid shaft output.  
*Les motoréducteurs du type A dispose d'arbre de sortie solides*

**Range of Ratios / Rapports de réduction**

72...820

**Applicable Motor Power / Puissance moteur applicable**

22 kW ... 132 kW

**Options / Options**

A type gearboxes units are foot mounted.  
*Les réducteurs de type A sont montés sur pattes.*

Designed for heavy industrial duties, the A / AE series present the advantages of being perfectly adapted to hard environment and tasks. The gears are designed to help the prevention of noise and vibrations during long and hard operations.

Conçue pour les applications industrielles lourdes, la série A / AE présente les avantages d'être parfaitement adaptée à l'environnement et aux tâches difficiles. Les engrenages sont conçus pour aider à prévenir le bruit et les vibrations lors d'opérations longues et difficiles.

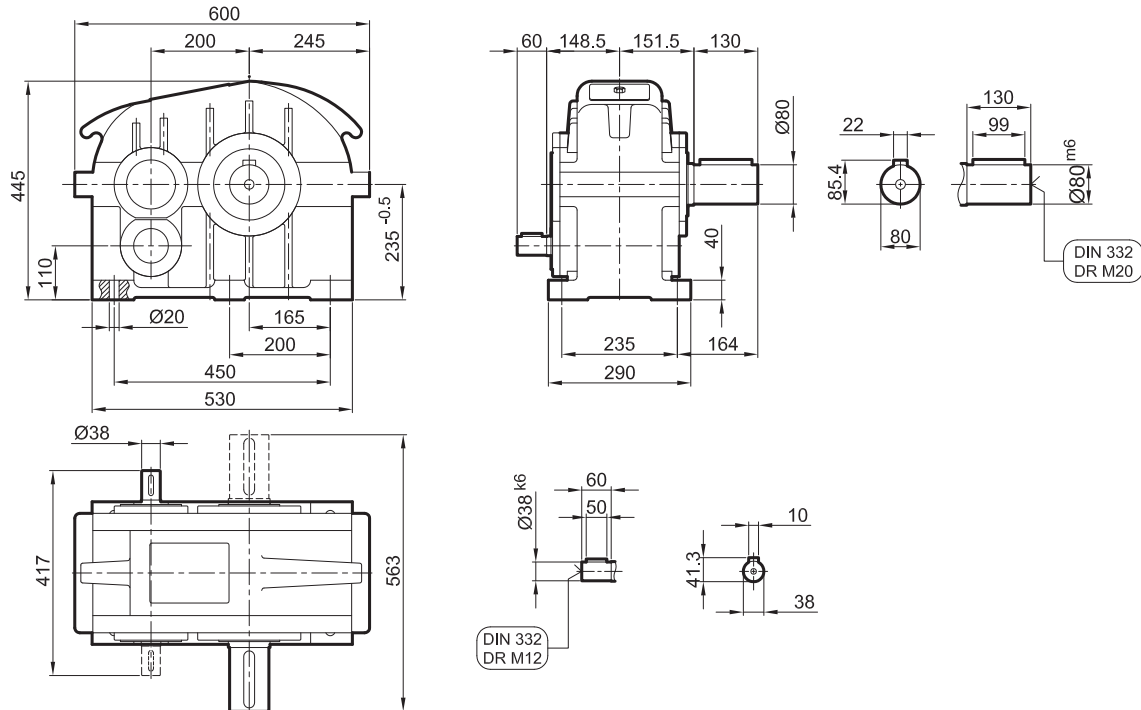

**Output Shaft Applications / Spécificités de l'arbre de sortie**

A type gearboxes have solid shaft output.  
*Les motoréducteurs du type A dispose d'arbre de sortie solides*

**Range of Ratios / Rapports de réduction**

20...195

**Applicable Motor Power / Puissance moteur applicable**

7,5 kW ... 45 kW

**Options / Options**

A type gearboxes units are foot mounted.  
*Les réducteurs de type A sont montés sur pattes.*

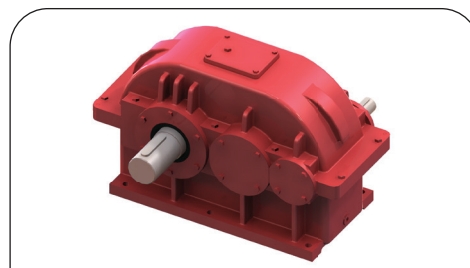

Type Type	Torque (Max) Couple (Max)	Shaft Diameter Diamètre de l'arbre de sortie
2A 200	6200 Nm	Ø 80

Designed for heavy industrial duties, the A / AE series present the advantages of being perfectly adapted to hard environment and tasks. The gears are designed to help the prevention of noise and vibrations during long and hard operations.

*Conçue pour les applications industrielles lourdes, la série A / AE présente les avantages d'être parfaitement adaptée à l'environnement et aux tâches difficiles. Les engrenages sont conçus pour aider à prévenir le bruit et les vibrations lors d'opérations longues et difficiles.*

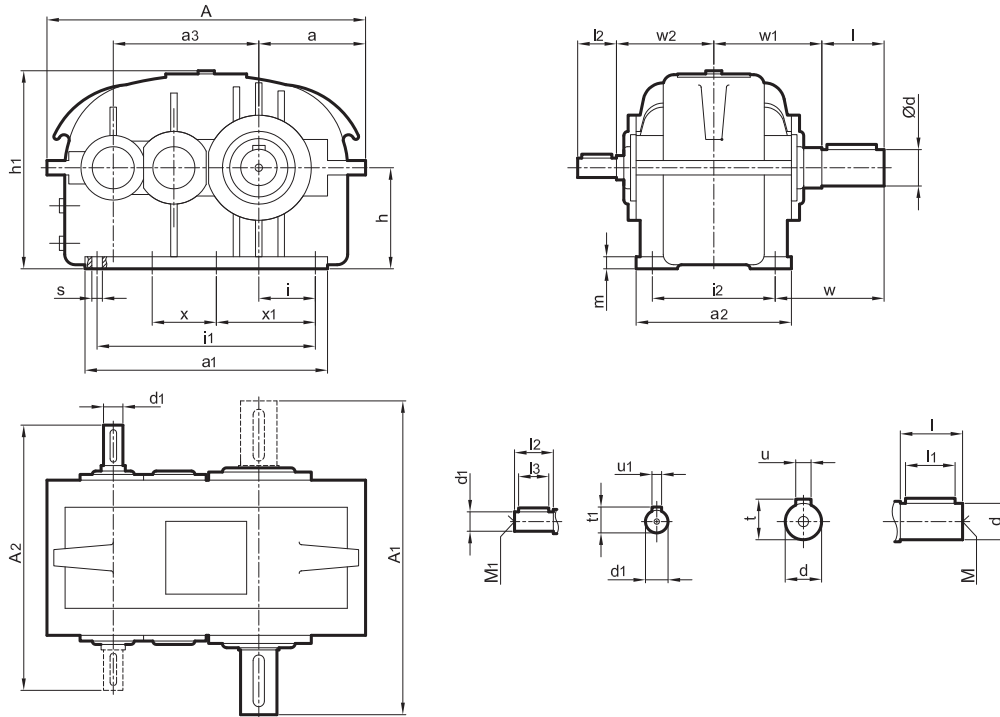

TYPE	A	A1	A2	Ød	l	t	u	l1	M	Ød1	l2	t1	u1	l3	M1	h <sup>-0.5</sup>	h1	Øs	i	i1	i2	x	x1	a1	a2	m	a	a3	w	w1	w2
2A 180	394	405	328	45	80	48,8	14	74	M16	24	50	27,3	8	38	M8	125	259	13	78	285	160	-	-	325	200	15	132	180	122,5	122,5	114
2A 225	480	436	366	55	90	59,3	16	75	M20	28	60	31,3	8	52	M10	143	302	15	93	340	174	-	-	390	220	25	162	225	131	128	123
2A 275	600	498	405	65	105	69,4	18	82	M20	32	60	35,3	10	50	M12	172	367	17	130	454	220	-	227	500	265	25	203	280	139	144	142,5
2A 350	720	600	488	80	130	85,4	22	106	M20	42	80	45,3	12	70	M16	215	443	20	140	530	260	-	270	600	310	30	242	350	170	170	164
2A 430	904	792	570	105	180	111,4	28	158	M24	45	80	48,8	14	70	M16	260	535	20	212	736	325	210	256	816	385	40	296	430	233	216	205
2A 500	1050	910	626	120	210	127,4	32	180	M24	50	100	53,8	14	85	M16	300	618	22	229	824	380	242	290	956	460	50	342	500	265	245	233

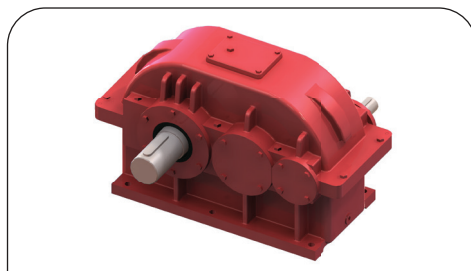

Type	Torque (Max) Couple (Max)	Shaft Diameter Diamètre de l'arbre de sortie
2A 180	880 Nm	Ø 45
2A 225	2040 Nm	Ø 55
2A 275	4107 Nm	Ø 65
2A 350	8000 Nm	Ø 80
2A 430	17000 Nm	Ø 105
2A 500	27000 Nm	Ø 120

**Output Shaft Applications / Spécificités de l'arbre de sortie**

A type gearboxes have solid shaft output.  
*Les motoréducteurs du type A dispose d'arbre de sortie solides*

**Range of Ratios / Rapports de réduction**

10...220

**Applicable Motor Power / Puissance moteur applicable**

0,37 kW ... 160 kW

**Options / Options**

A type gearboxes units are foot mounted.  
*Les réducteurs de type A sont montés sur pattes.*

Designed for heavy industrial duties, the A / AE series present the advantages of being perfectly adapted to hard environment and tasks. The gears are designed to help the prevention of noise and vibrations during long and hard operations.

*Conçue pour les applications industrielles lourdes, la série A / AE présente les avantages d'être parfaitement adaptée à l'environnement et aux tâches difficiles. Les engrenages sont conçus pour aider à prévenir le bruit et les vibrations lors d'opérations longues et difficiles.*

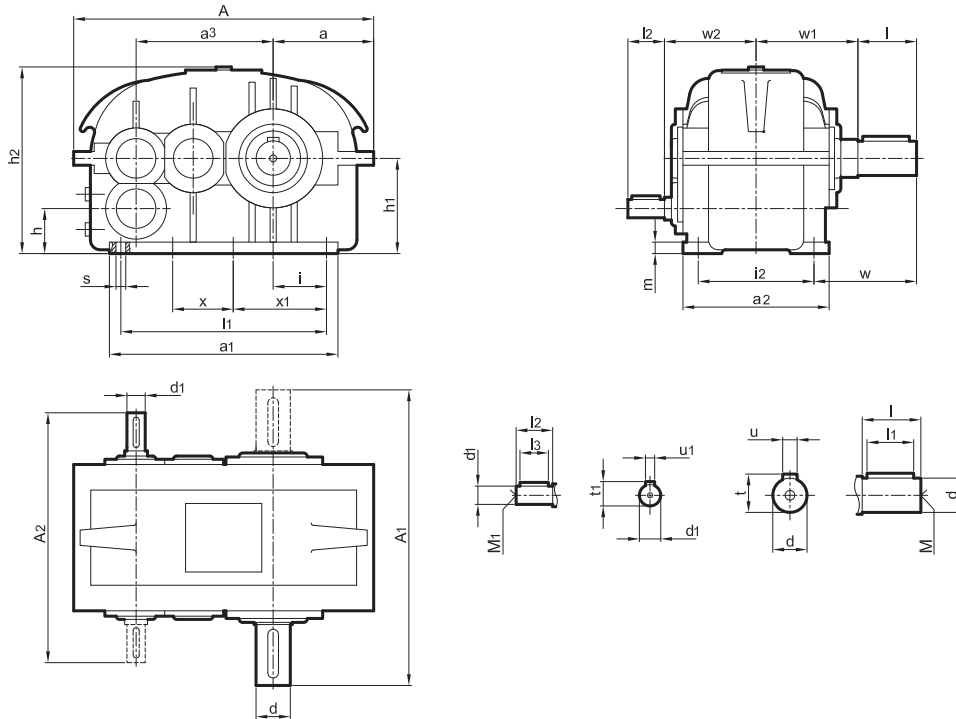

TYPE	A	A <sub>1</sub>	A <sub>2</sub>	Ød	l	t	u	l <sub>1</sub>	M	Ød <sub>1</sub>	l <sub>2</sub>	t <sub>1</sub>	u <sub>1</sub>	l <sub>3</sub>	M <sub>1</sub>	h <sup>-0.5</sup>	h <sub>1</sub> <sup>-0.5</sup>	h <sub>2</sub>	Øs	i	i <sub>1</sub>	i <sub>2</sub>	x	x <sub>1</sub>	a <sub>1</sub>	a <sub>2</sub>	m	a	a <sub>3</sub>	w	w <sub>1</sub>	w <sub>2</sub>
<b>3A 430</b>	904	792	570	105	180	111,4	28	158	M24	42	80	45,3	12	72	M16	135	260	535	20	212	736	325	210	256	816	385	40	296	430	233	216	205
<b>3A 500</b>	1050	910	626	120	210	127,4	32	180	M24	42	80	45,3	12	60	M16	165	300	618	22	229	824	380	242	290	956	460	50	342	500	265	245	233

**Output Shaft Applications / Spécificités de l'arbre de sortie**

A type gearboxes have solid shaft output.  
*Les motoréducteurs du type A dispose d'arbre de sortie solides*

**Range of Ratios / Rapports de réduction**

1,6...56

**Applicable Motor Power / Puissance moteur applicable**

1,5 kW ... 75 kW

**Options / Options**

A type gearboxes units are foot mounted.  
*Les réducteurs de type A sont montés sur pattes.*

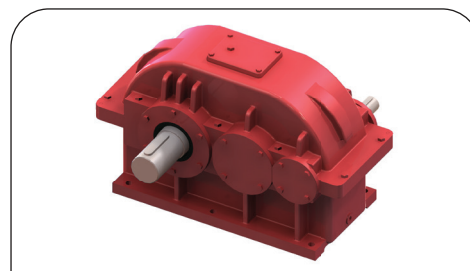

Type	Torque (Max) Couple (Max)	Shaft Diameter Diamètre de l'arbre de sortie
3A 430	17000 Nm	Ø 105
3A 500	27000 Nm	Ø 120

Designed for heavy industrial duties, the A / AE series present the advantages of being perfectly adapted to hard environment and tasks. The gears are designed to help the prevention of noise and vibrations during long and hard operations.

*Conçue pour les applications industrielles lourdes, la série A / AE présente les avantages d'être parfaitement adaptée à l'environnement et aux tâches difficiles. Les engrenages sont conçus pour aider à prévenir le bruit et les vibrations lors d'opérations longues et difficiles.*

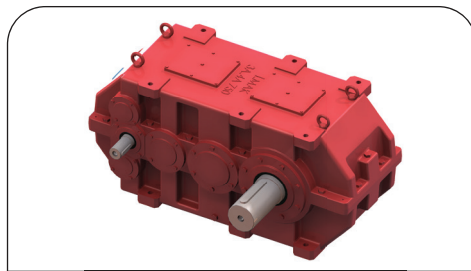
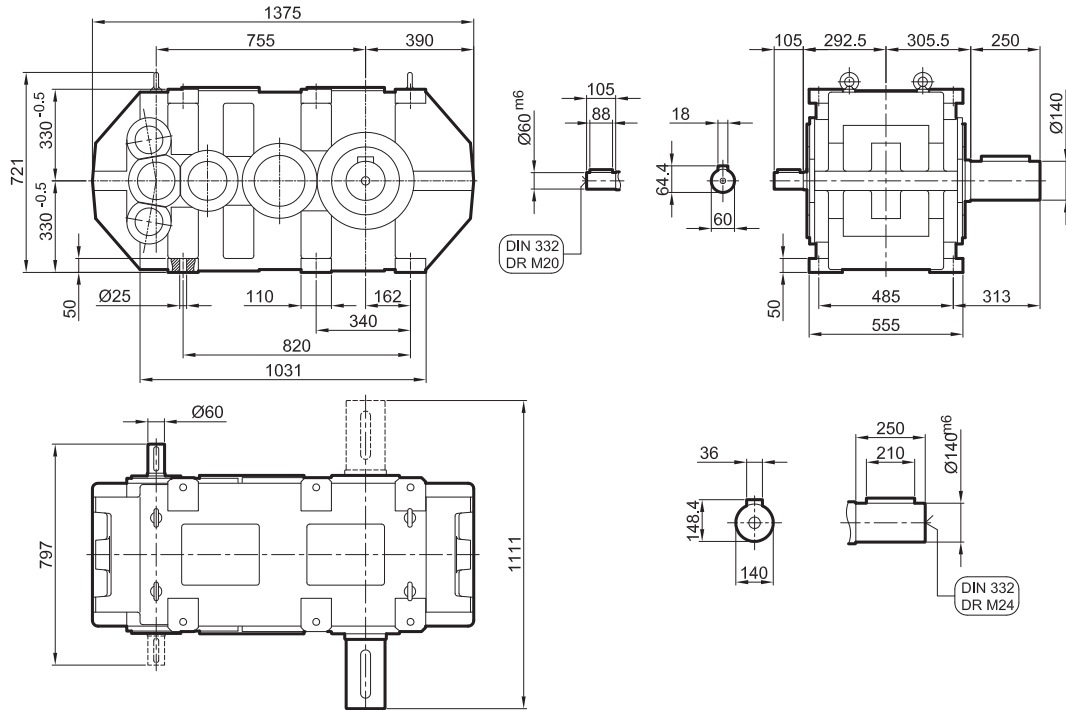

Type <i>Type</i>	Torque (Max) <i>Couple (Max)</i>	Shaft Diameter <i>Diamètre de l'arbre de sortie</i>
3A 750	33000 Nm	Ø 140

**Output Shaft Applications / Spécificités de l'arbre de sortie**

A type gearboxes have solid shaft output.  
*Les motoréducteurs du type A dispose d'arbre de sortie solides*

**Range of Ratios / Rapports de réduction**

3,5...293

**Applicable Motor Power / Puissance moteur applicable**

3 kW ... 185 kW

**Options / Options**

A type gearboxes units are foot mounted.  
*Les réducteurs de type A sont montés sur pattes.*

Designed for heavy industrial duties, the A / AE series present the advantages of being perfectly adapted to hard environment and tasks. The gears are designed to help the prevention of noise and vibrations during long and hard operations.

Conçue pour les applications industrielles lourdes, la série A / AE présente les avantages d'être parfaitement adaptée à l'environnement et aux tâches difficiles. Les engrenages sont conçus pour aider à prévenir le bruit et les vibrations lors d'opérations longues et difficiles.

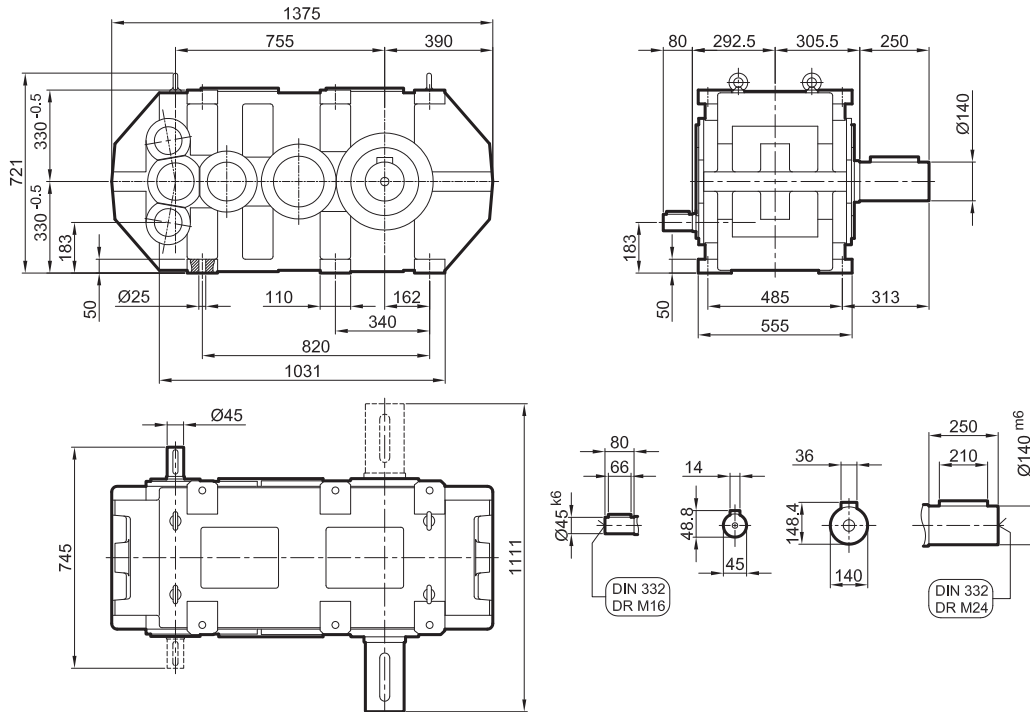

**Output Shaft Applications / Spécificités de l'arbre de sortie**

A type gearboxes have solid shaft output.  
*Les motoréducteurs du type A dispose d'arbre de sortie solides*

**Range of Ratios / Rapports de réduction**

1...9

**Applicable Motor Power / Puissance moteur applicable**

1,1 kW ... 15 kW

**Options / Options**

A type gearboxes units are foot mounted.  
*Les réducteurs de type A sont montés sur pattes.*

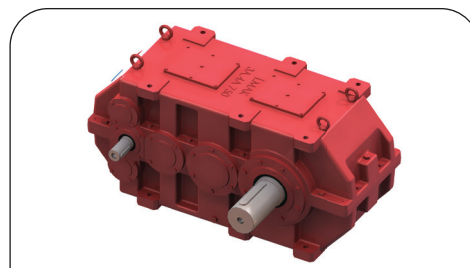

Type Type	Torque (Max) Couple (Max)	Shaft Diameter Diamètre de l'arbre de sortie
4A 750	33000 Nm	Ø 140

**A STRONG NETWORK**

**I-MAK Turkey (Factory-Head Office)**

Seyhli Mahallesi, Sanayi Caddesi No:1, 34906 Pendik / İstanbul –  
Turkey Tel: +90 216 378 03 26 - Fax: +90 216 378 06 86  
Web: [www.imakreduktor.com](http://www.imakreduktor.com) / E-mail: [imak@imakreduktor.com](mailto:imak@imakreduktor.com)

**I-MAK Morocco**

Quartier industriel SAPINO Lot n°72- Nouacer, Casablanca-Maroc  
Tel: +212 588 408 757 - Fax: +212 522 408 756  
E-mail: [adv@alamitec.ma](mailto:adv@alamitec.ma)

**I-MAK France**

Zac de Montrambert - piegot, 42150 La Ricamarie, France  
Tel: +33 (0)6 19 27 10 48  
E-mail: [transmission@unicum.fr](mailto:transmission@unicum.fr)

**I-MAK Ukraine**

Levanevs'koho St, 77, Bila Tserkva, Kyivs'ka oblast, Ukraine  
Tel: +38 044 221 18 89  
E-mail: [technoprivod@ymail.com](mailto:technoprivod@ymail.com)

**I-MAK Poland**

Kochlice ul. Lubińska 1C, Milkowice, 59-222 Kochlice, Poland  
Tel: +48 76 852 21 17  
E-mail : [service@iow.pl](mailto:service@iow.pl)

**I-MAK Ecuador**

Av.Francisco de Orellana Km 4.5 C.Comercial la Gran Manzana Local 70  
Bodega & Taller Cdla.Urbanor Mz. 107 Villa 29 Ecuador Guayaquil  
[stalin.espinoza@sercorpvi.com](mailto:stalin.espinoza@sercorpvi.com)

**I-MAK Colombia**

Calle 15 No. 2A - 38 Funza, Cundinamarca, Bogota / Colombia  
Tel: +57 (1) 8237752 - 8237736 - 3165233927  
E-mail: [info@motoresyenergia.com](mailto:info@motoresyenergia.com)

**I-MAK South Africa**

72 Acacia Road, Primrose,  
Germiston  
Tel: +27 11 828 9715 E-Mail: [info@hpts.co.za](mailto:info@hpts.co.za)

**I-MAK Turkey (Sales Office)**

Demirkapi Mah. Riza Uzun Sok. D:5, 34030 Eyup / Istanbul –Turkey  
Tel: +90 212 567 87 32/33 - Fax: +90 212 612 61 17  
E-mail: [imak@imakreduktor.com](mailto:imak@imakreduktor.com) / [export@imakreduktor.com](mailto:export@imakreduktor.com)

**I-MAK USA**

12610 Galveston Road, Webster, 77598 Texas, USA.  
Tel: +1 281 480 8711 ext 200 / Fax: +1 281 480 8656  
E-mail: [sales@sipco-imak.com](mailto:sales@sipco-imak.com)

**I-MAK Italy**

Via Maestri del Lavoro 10/B 42122 Reggio Emilia Italy  
Tel: 0039 059 5961376  
E-mail: [imak.italy@imakreduktor.com](mailto:imak.italy@imakreduktor.com)

**I-MAK Netherlands**

Parlevinkerweg 44, 5928 NV Venlo, The Netherlands  
Tel: +31-77-3968781  
E-mail: [info@aandrijftechnischburo.nl](mailto:info@aandrijftechnischburo.nl)

**I-MAK India**

Indus Valley's Logistic Park Unit 3-Vellala Street, Chennai, India  
Tel: +91 4465681815  
E-mail: [info@mgmvarvelindia.com](mailto:info@mgmvarvelindia.com)

**I-MAK Russia**

142718 Moscow region. S.Bulatnikovskoe, building 1, office 404, Russia  
Tel: +7(499) 677 52 13 +7(929) 976 12 26 / +7(967) 130 49 63  
E-Mail : [info@imak.ru](mailto:info@imak.ru)

**I-MAK Spain**

Polígono Industrial A Reigosa Parcela B-33,  
36828 Ponte Caldelas, Pontevedra, España  
Tel: (+34) 986 872 010

**I-MAK Egypt**

Egypt - 6th October City – Laylat Al – Qadr Square – Almajed Center  
Tel: +20 102 454 6254 / +20 102 262 1584  
E-mail: [export@imakreduktor.com](mailto:export@imakreduktor.com)

**TRUSTABLE PARTNERS**

Algeria / Azerbaijan / Belarus / Bulgaria / Bosnia / Canada / Dubai / Ecuador / Germany / Hungary / Indonesia / Iraq / Ivory Coast /  
Jordan / Kazakhstan / Kenya / Malaysia / Mexico / Pakistan / Peru / Romania / Saudi Arabia / Serbia / Slovakia / Spain / Sweden /  
Tunisia / Uzbekistan / Vietnam

[www.imakreduktor.com](http://www.imakreduktor.com)



American  
Gear Manufacturers  
Association